

Sealing flange and flywheel/drive plate, removing and installing

Note:

For clutch repairs:

⇒ [Repair Manual, 5 Spd. Manual Transmission 02J, Repair Group 30](#)

1 - 120 Nm (89 ft lb) + 1/4 turn (90°) additional

- ◆ Always replace
- ◆ Threads and shoulder must be free of oil and grease
- ◆ To loosen and tighten, counter-hold with 3415
- ◆ Torque angle can be measured with Hazet 6690 torque angle meter, or equivalent

2 - Crankshaft toothed belt sprocket

3 - 15 Nm (11 ft lb)

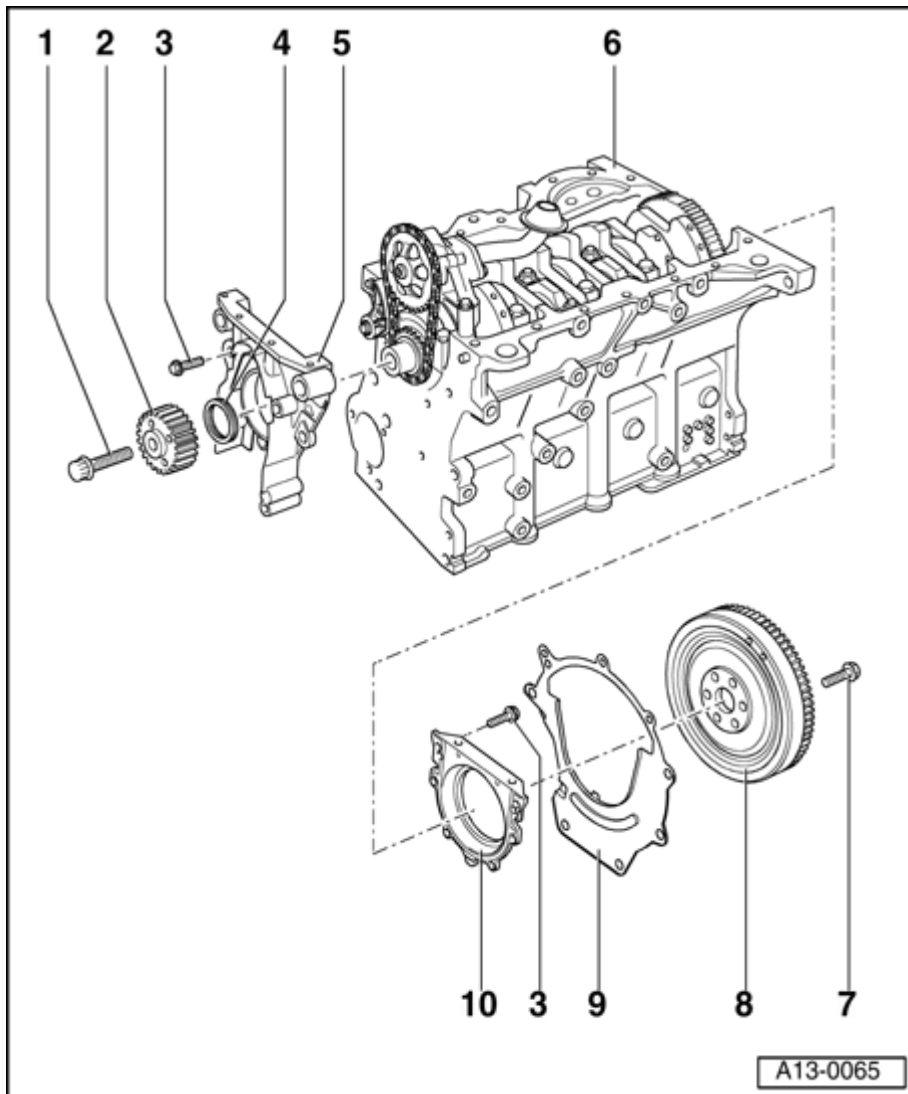

4 - Oil seal

- ◆ Replacing ⇒ [Page 13-34](#)

5 - Sealing flange, front

- ◆ Must be located on dowel sleeves
- ◆ Removing and installing ⇒ [Page 13-39](#)
- ◆ Replace using D 176 404 A2 silicone sealant ⇒ [Page 13-38](#)

6 - Engine block

- ◆ Crankshaft, removing and installing ⇒ [Page 13-45](#)
- ◆ Pistons and connecting rods, disassembling and assembling ⇒ [Page 13-51](#)

7 - 60 Nm (44 ft lb) + 1/4 turn (90°) additional

- ◆ Always replace
- ◆ Torque angle can be measured with Hazet 6690 torque angle meter, or equivalent

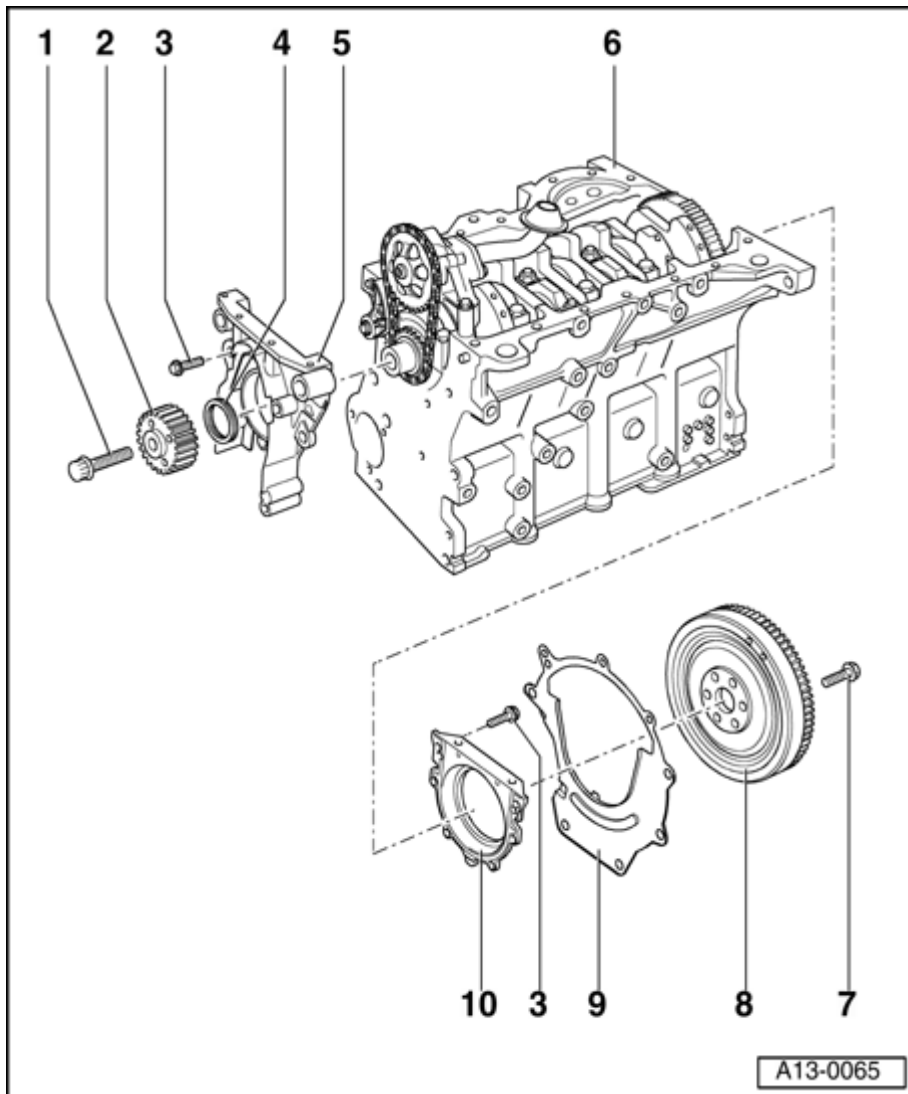

8 - Flywheel/drive plate

- ◆ Counter-hold using 3067 to remove and install flywheel
- ◆ Drive plate, removing and installing ⇒ [Page 13-42](#)

9 - Intermediate plate

- ◆ Must be located on dowel sleeves ⇒ Fig. ⇒ [1](#)
- ◆ Do not damage or bend when assembling

10 - Sealing flange with PTFE oil seal

- ◆ Only replace as an assembly
- ◆ Only install flange with PTFE oil seal
- ◆ Do not install seal using oil or grease
- ◆ Oil pan, removing and installing ⇒ [Page 17-10](#)
- ◆ Install using supplied guide sleeve (do not remove sleeve tool before installing sealing flange)

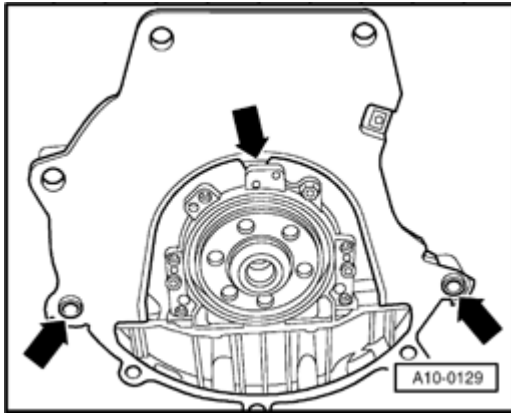

A

Fig. 1 Intermediate plate must be located on dowel sleeves (arrows)

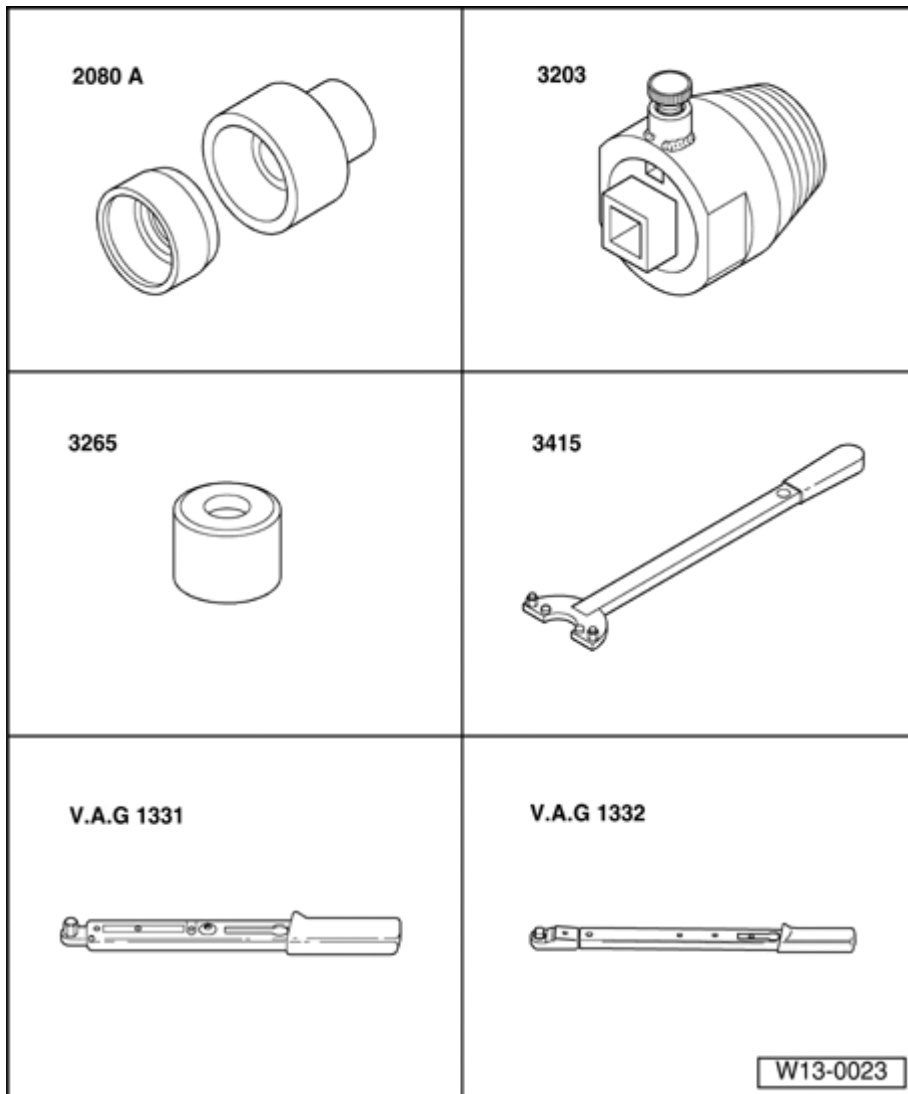

Crankshaft seal (pulley side), replacing

Special tools

- ◆ 2080 A sleeve
- ◆ 3203 Oil seal extractor
- ◆ 3265 Sleeve
- ◆ 3415 Counter-holder
- ◆ VAG 1331 Torque wrench 5 to 50 Nm (3.7 to 37 ft lb) or equivalent
- ◆ VAG 1332 Torque wrench 40 to 200 Nm (30 to 148 ft lb) or equivalent



Removing

- Remove ribbed belt ⇒ [Page 13-12](#)
- Remove toothed belt ⇒ [Page 13-16](#)
- A** - Remove crankshaft toothed belt sprocket by counter-holding sprocket using 3415.

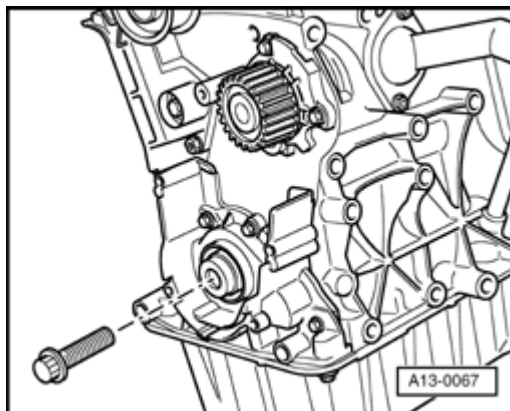
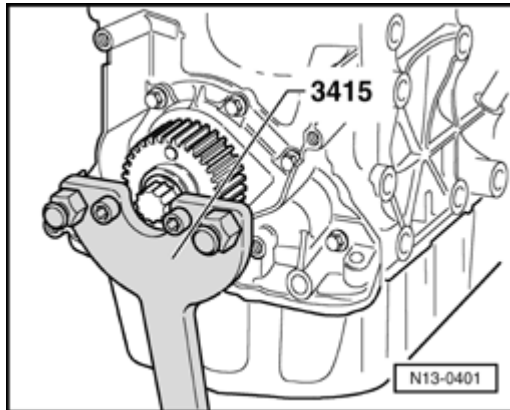

- A** - To guide seal extractor, hand thread center bolt into crankshaft onto stop.
- Unscrew inner part of oil seal extractor 3203 two turns (approx. 3 mm) out of outer part and lock with knurled screw.

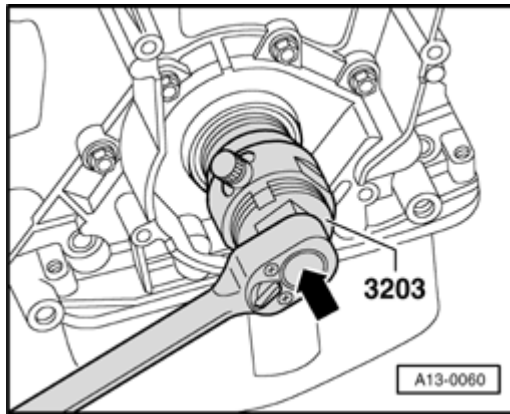

A

- Lubricate threaded head of 3203 oil seal extractor, place in position and while exerting firm pressure, thread into oil seal as far as possible.
- Loosen knurled screw and turn inner part against crankshaft until oil seal is pulled out.
- Clamp oil seal extractor in a vise and remove oil seal using pliers.

Installing

- Lightly oil sealing lip of oil seal.

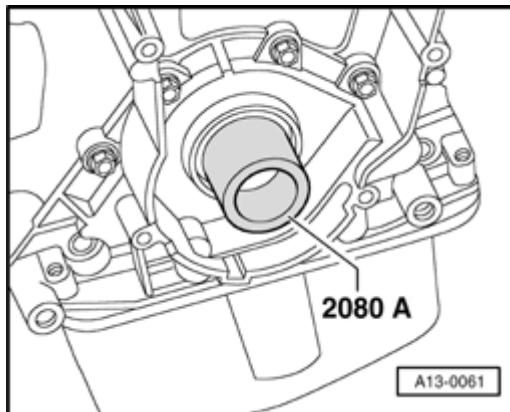

A

- Install guide sleeve from 2080 A onto crankshaft journal.
- Slide oil seal over guide sleeve.

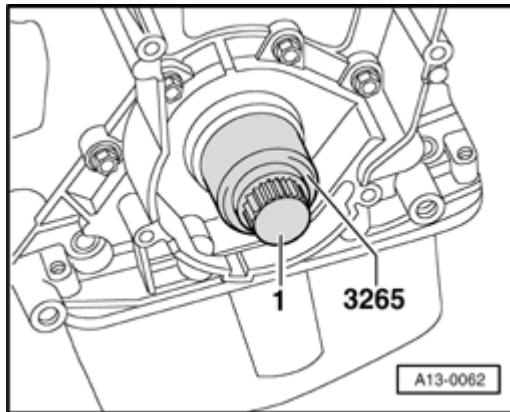

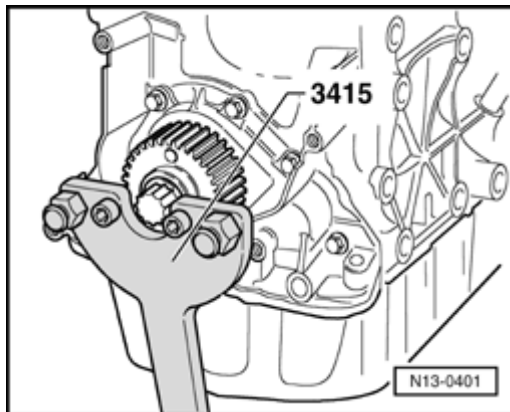

- A**
- Press in sealing ring with press sleeve from 3265 up to the stop using center bolt -1-.



- A**
- Install crankshaft toothed belt sprocket and hold using 3415 counter-hold tool. Tightening torque: 120 Nm (89 ft lb) + additional 1/4 turn (90°)
 - Install toothed belt and adjust tension ⇒ [Page 13-16](#) .
 - Install ribbed belt ⇒ [Page 13-12](#) .

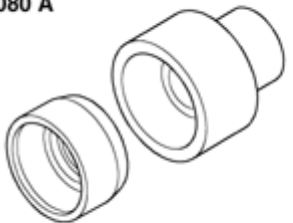
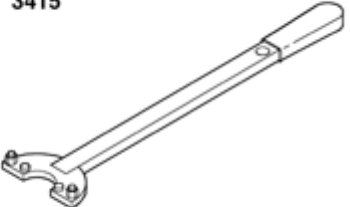

<p>2080 A</p> 	<p>3415</p> 
<p>V.A.G 1331</p> 	<p>V.A.G 1332</p> 
<p style="text-align: right;">W13-0022</p>	

Sealing flange (front), removing and installing

Special tools and equipment

- ◆ 2080 A Guide sleeve
- ◆ 3415 Counter-hold tool
- ◆ VAG 1331 Torque wrench (5 to 50 Nm) (3.7 to 37 ft lb) or equivalent
- ◆ VAG 1332 Torque wrench (40 to 200 Nm) (30 to 148 ft lb) or equivalent
- ◆ Hand drill with plastic brush insert (not shown)
- ◆ D 176 404 A2 Silicone sealer (not shown)
- ◆ Flat scraper (not shown)
- ◆ Protective goggles (not shown)



Removing

- Remove ribbed belt ⇒ [Page 13-12](#) .
- Remove toothed belt ⇒ [Page 13-16](#) .

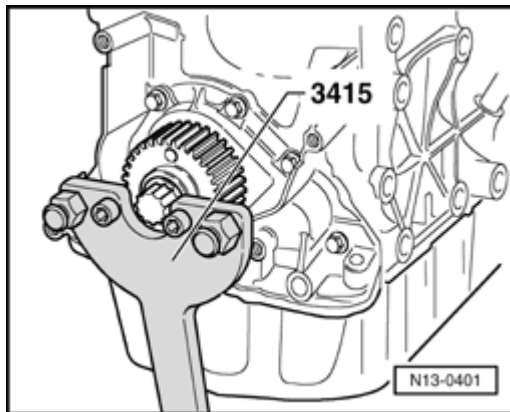

- A - Remove crankshaft toothed belt sprocket by counter-holding sprocket using 3415.
- Remove oil pan ⇒ [Page 17-10](#) .
- Unbolt front sealing flange.
- Remove sealing flange and if necessary, release using light tabs with a rubber hammer.
- Remove sealant residue on engine block with a flat scraper.

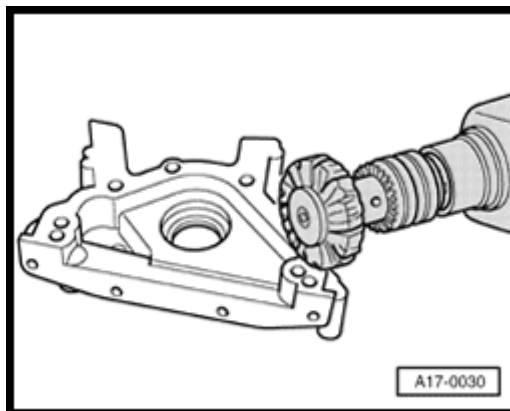

- A - Remove sealant remains on sealing flange with a rotating plastic brush (wear protective goggles).
- Clean sealing surface.
 - Surface must be free of oil and grease



Installing

Note:

- ◆ Observe the "must be used by" date on the sealant tube.
- ◆ Oil pan must be installed within 5 minutes after applying silicone sealing compound.

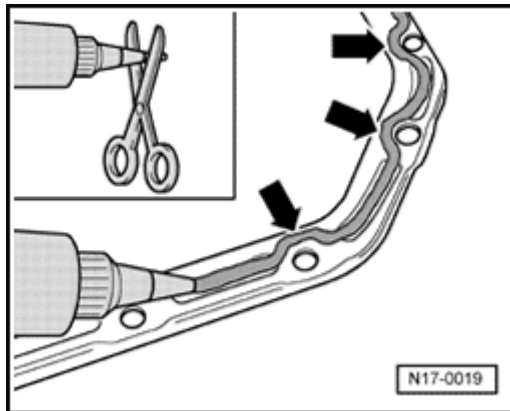

A

- Cut off tube nozzle at forward mark (nozzle approx. 3 mm diameter)
- Apply silicone sealing compound as shown to clean oil pan sealing surface.
 - Thickness of sealant bead must be (arrows): 2 to 3 mm
 - Bead of sealant must be placed inside of bolt holes (arrows)

CAUTION!

The sealing compound bead thickness specification must NOT be thicker, otherwise excess sealing compound will enter the oil pan and could block the oil suction pipe strainer.

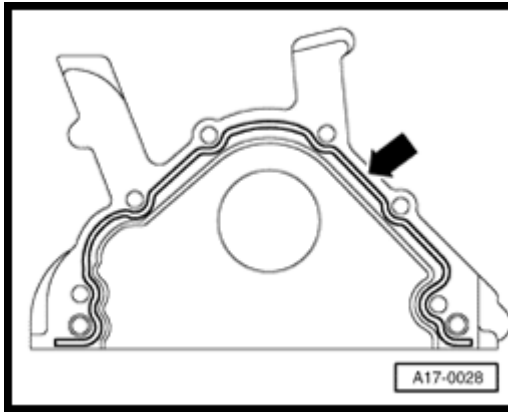

A

- Apply silicone sealant bead as shown to clean sealing surface of sealing flange.
- Install sealing flange immediately, then lightly tighten all bolts.

Note:

Use guide sleeve from 2080A to install the sealing flange if the oil seal is already installed.

- Tighten sealing flange mounting bolts using a diagonal staggered tightening pattern.
Tightening torque: 15 Nm (11 ft lb)
- Install oil pan ⇒ [Page 17-10](#) .

Note:

Allow the sealant to dry for approx. 30 minutes after installation before adding engine oil.

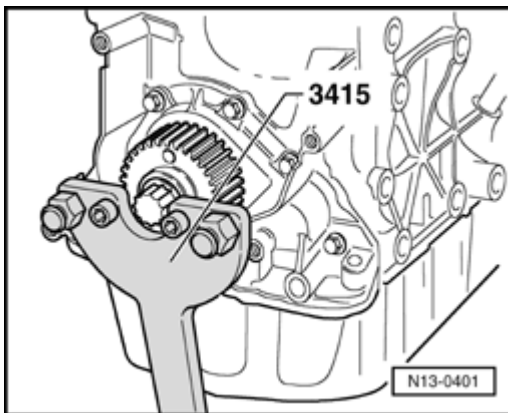

A

- Install crankshaft toothed belt sprocket and hold using 3415 counter-hold tool.
Tightening torque: 120 Nm (89 ft lb) + additional 1/4 turn (90°)
- Install toothed belt and adjust tension ⇒ [Page 13-16](#) .
- Install ribbed belt ⇒ [Page 13-12](#) .



Drive plate, removing and installing

Special tools

- A**
- ◆ VW 558 Counter-hold tool
 - ◆ Hex bolt M8x45 and two M10 hex nuts
 - ◆ Depth gauge

Loosening and tightening

- A**
- Secure VW 558 counter-hold to drive plate using M8 x 45 hex bolt.
 - Place two M10 hex nuts between counter-hold and drive plate.

Position of counter-hold tool:

- A - To loosen
- B - To tighten

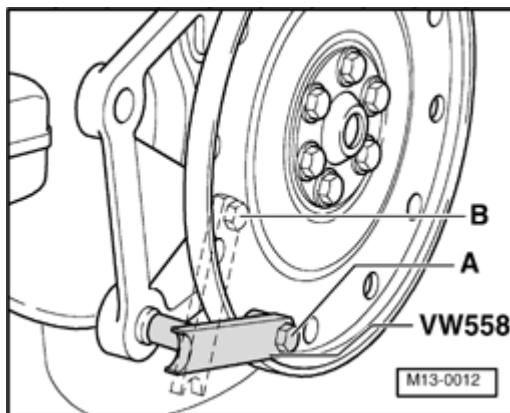
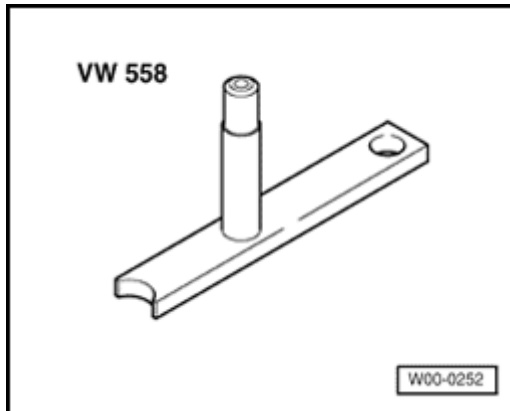



Installing

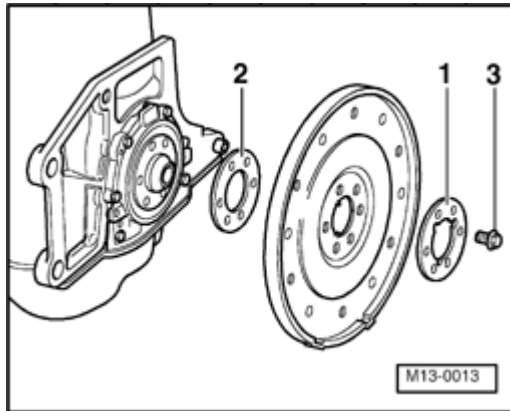

- A - Position drive plate and backing plate with recesses -1-.
- Install new bolts -3- and tighten. Tightening torque: 30 Nm (22 ft lb)

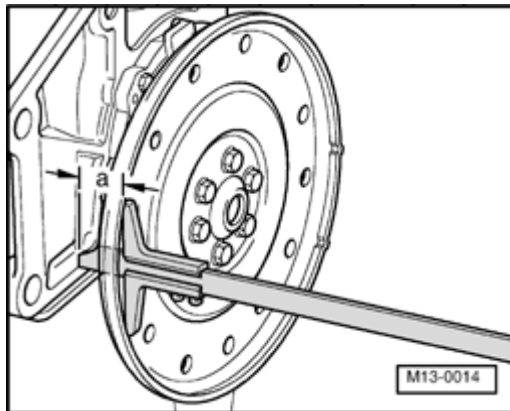

- A - Check dimension -a- at three points and calculate average.
 - Specification: 19.5 to 21.1 mm

Note:

Measure through holes in drive plate to milled surface of engine block.

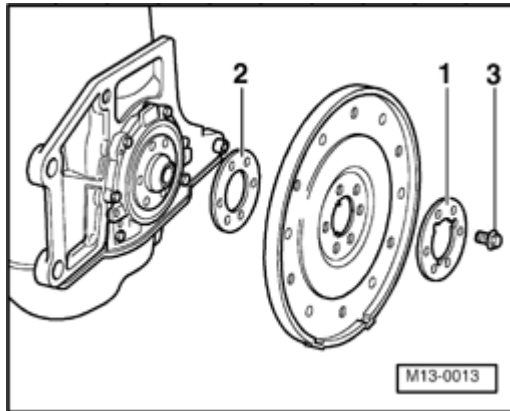

If specification not obtained:

A

- Remove drive plate and install shim -2-.
- Tighten bolts -3-. Tightening torque: 30 Nm (22 ft lb)
- Tighten bolts -3- to 60 Nm (44 ft lb) + additional 90° (1/4 turn) further.

Note:

The additional 90° can be achieved in more than one step.