

Engine Code - PG

Clutch flywheel

- [assembly](#)

Crankshaft, crankcase

- [assembly](#)
- [dimensions](#)
- [ignition mark](#)
- [oil seal, removing/installing](#)

Cylinder block

- [assembly](#)

Cylinder head

- [assembly](#)

Drive belt

- [installing](#)

G-charger, A/C brackets

- [assembly](#)

Piston, connecting rod

- [assembly](#)
- [cylinder bore, checking](#)
- [dimensions](#)
- [piston rings, checking](#)

Engine Code - AAA

Clutch, flywheel

- [assembly](#)

Crankshaft

- [assembly](#)
- [dimensions](#)
- [oil seal, drive belt side removing/installing](#)

Cylinder block

- [assembly](#)
- [bore, checking](#)

Cylinder head

- [assembly](#)

Drive chains

- [assembly sprockets](#)
- [installing lower tensioner](#)
- [marking direction of travel](#)

Drive plate

- [removing/installing](#)

Pistons

- [assembly with connecting rod](#)
- [checking](#)
- [dimensions](#)
- [rings, end gap checking](#)
- [ring, side clearance](#)

Poly-ribbed belt

- [removing/installing](#)

Valve timing

- [adjusting](#)

Volkswagen Corrado 1990 - 1994
General Engine
Engine - Crankshaft, Crankcase (Page 13-2)

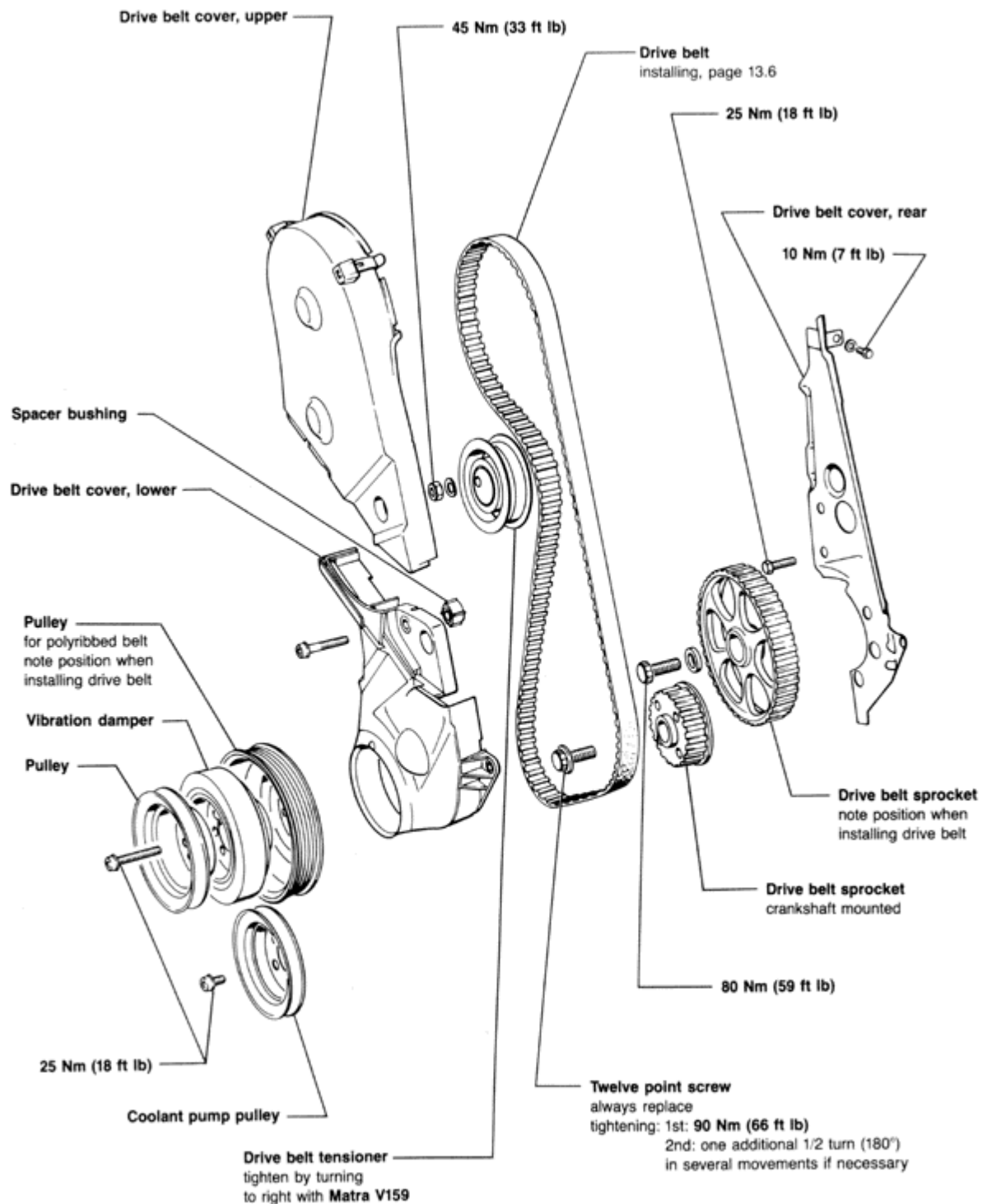

Volkswagen Corrado 1990 - 1994
General Engine
Engine - Crankshaft, Crankcase (Page 13-3)

CAUTION!

Coolant/anti-freeze must not be reused when replacing engine, cylinder head, cylinder head gasket, radiator and heater core.

CAUTION!

Always replace gaskets and seals

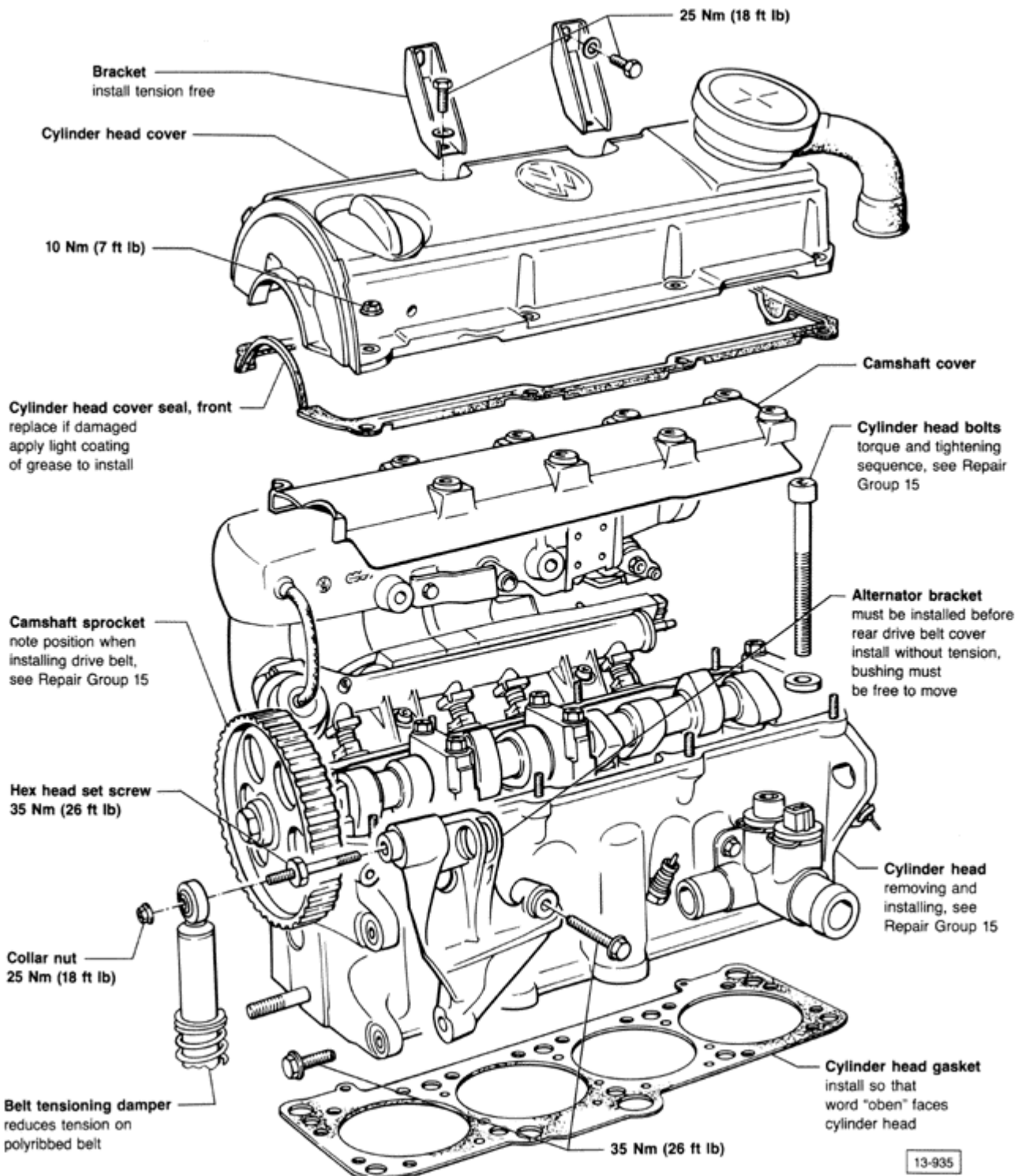

Volkswagen Corrado 1990 - 1994
 General Engine
 Engine - Crankshaft, Crankcase (Page 13-4)

CAUTION!

If you find metal shavings in the engine oil as a result of engine damage; clean oil passages thoroughly, then replace oil cooler and oil filter.

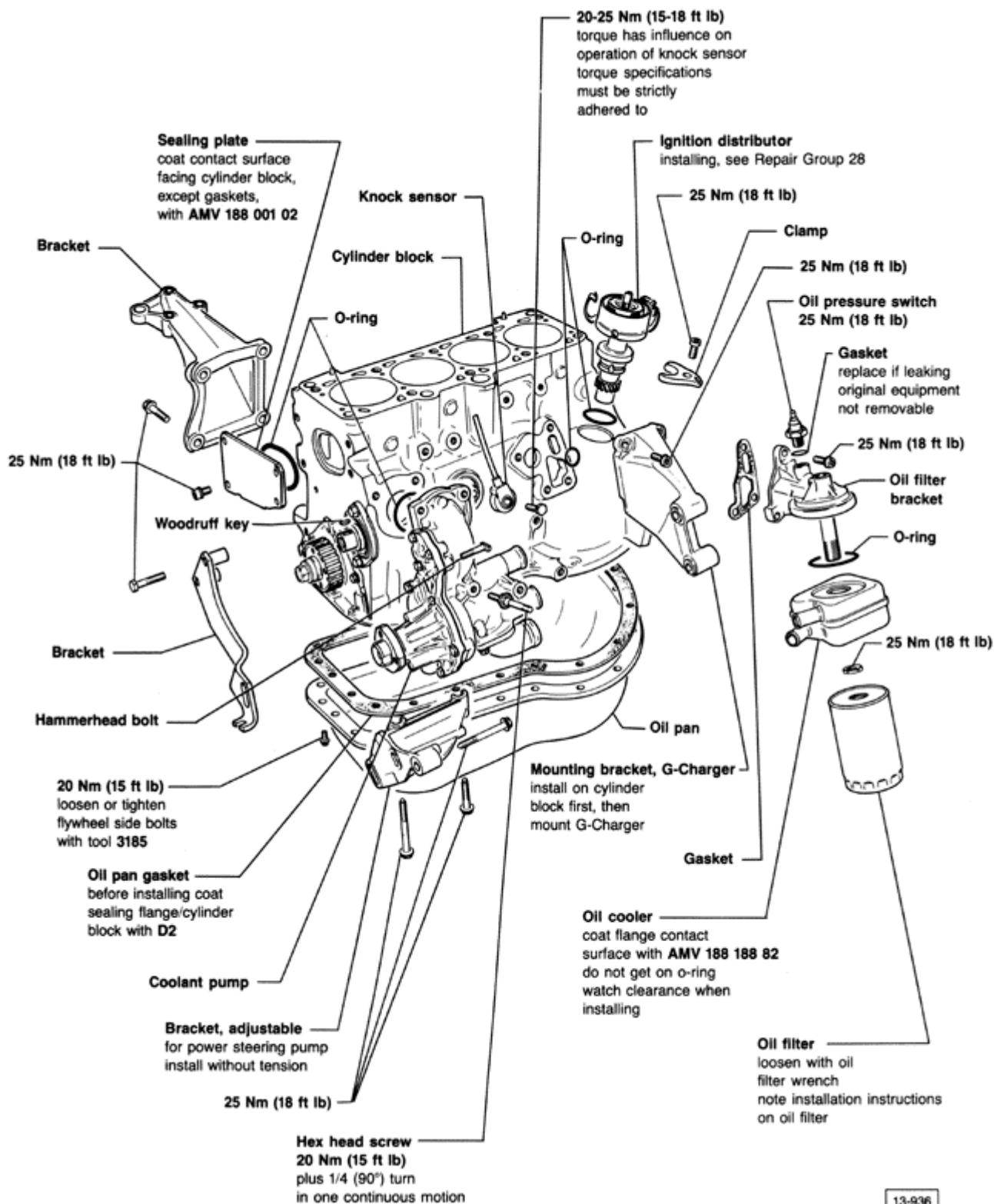

Volkswagen Corrado 1990 - 1994
General Engine
Engine - Crankshaft, Crankcase (Page 13-5)

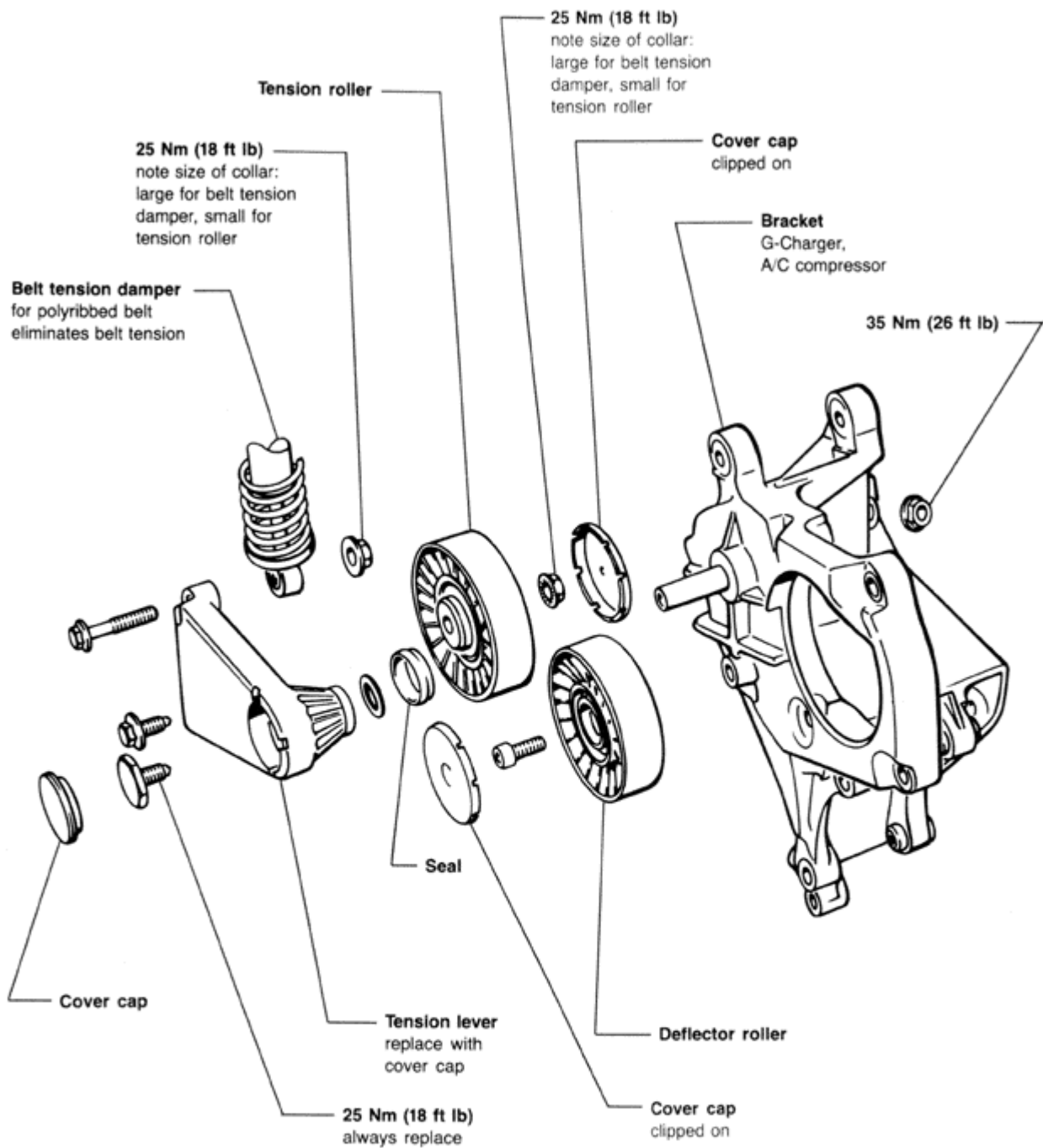

Volkswagen Corrado 1990 - 1994
General Engine
Engine - Crankshaft, Crankcase (Page 13-6)

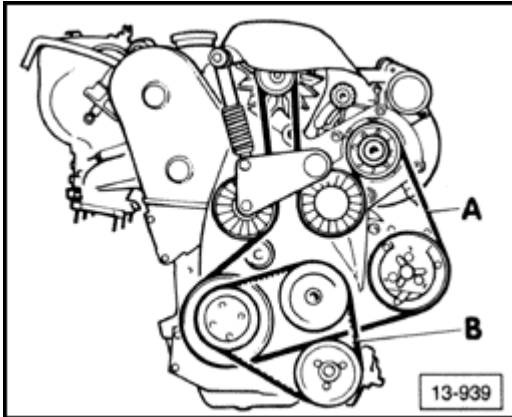

A

Fig. 1 Belt routing

A - Polyribbed belt

B - Drive belt

- Tension drive belt, see [Repair Group 48](#)

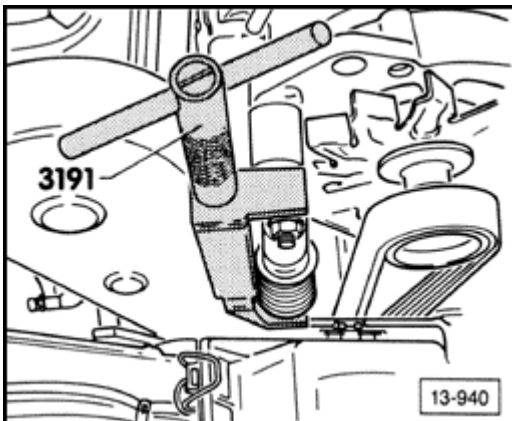

A

Fig. 2 Tensioning polyribbed belt

- tension using tool 3191

Drive belt, installing

(setting valve timing)

Notes

*The crankshaft must **not** be at TDC.*

- mount drive belt on crankshaft and intermediate shaft sprockets
- mount pulley and vibration dampener on crankshaft with all four fasteners
 - note installation position

Cylinder head cover, installing

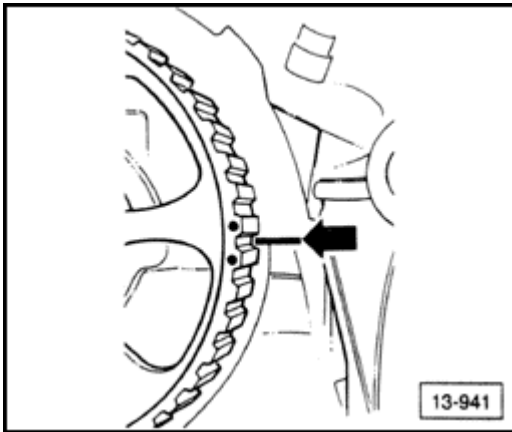

A

- align mark on cover with marks on camshaft sprocket

Cylinder head cover, removing

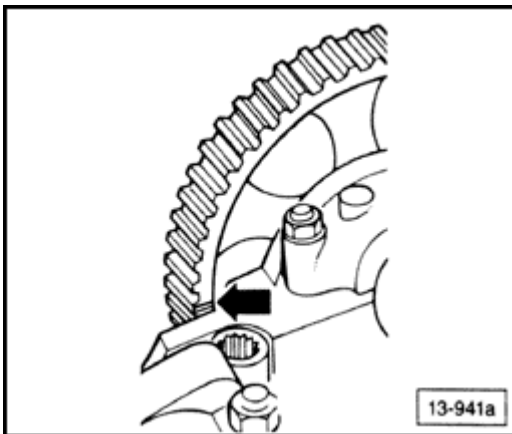

A

- align mark on camshaft sprocket with cylinder head cover

Volkswagen Corrado 1990 - 1994
General Engine
Engine - Crankshaft, Crankcase (Page 13-7)

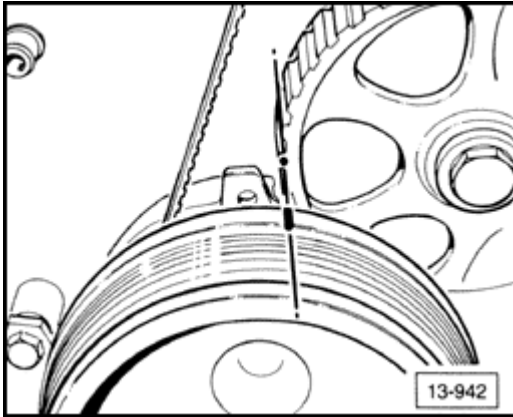

A

- align mark on crankshaft pulley/vibration dampener with mark on intermediate sprocket (TDC cylinder 1)
- mount drive belt on camshaft sprocket
- tighten drive belt by turning tensioner in direction of **arrow**
 - it must be possible to twist drive 90° in center between camshaft and intermediate sprockets

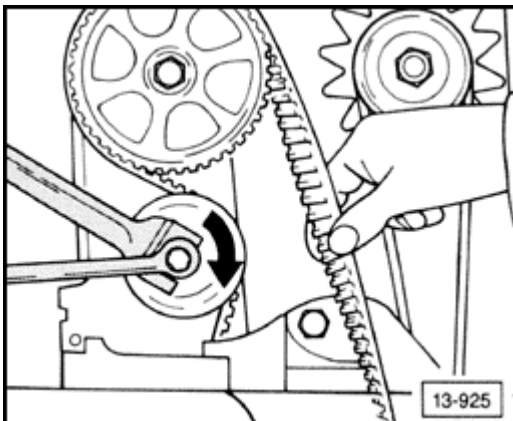

A

- tighten lock nut on tensioner
 - torque 45 Nm (33 ft lb)
- turn crankshaft pulley twice and recheck drive belt tension
- remove crankcase pulley and vibration dampener
- install lower drive belt cover
- install upper drive belt cover, v-belt pulley, vibration dampener and drive belt
- check ignition timing, if necessary, adjust

Notes

If drive belt was removed from the camshaft sprocket, adjust belt as follows:

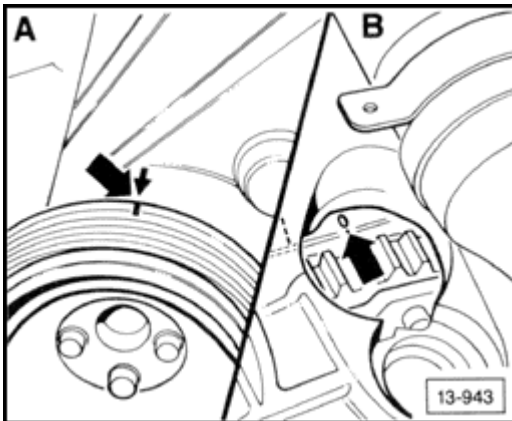

A

Engine removed

- align mark on drive belt tensioner and drive belt cover (**left arrow**)

Engine installed

- align TDC mark **0** on flywheel with mark on housing (**right arrow**)

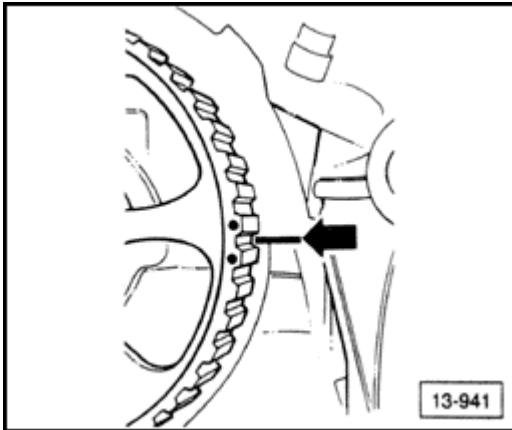

A

Cylinder head cover, installing

- align mark on cover with marks on camshaft sprocket

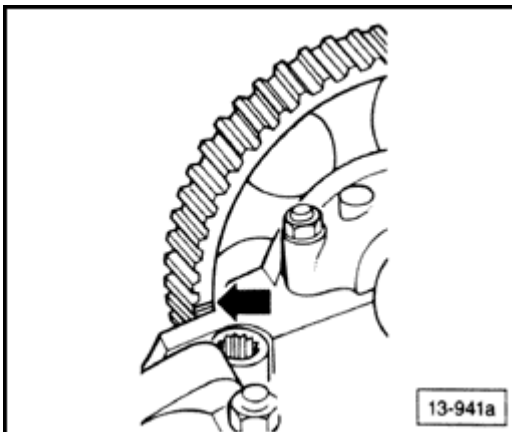

A

Cylinder head cover, removing

- align mark on camshaft sprocket with cylinder head cover
- mount drive belt and tighten
- check if ignition distributor rotor is pointing to marking for cylinder 1 on distributor housing. If not, turn distributor until mark and rotor align. If necessary install a new distributor
- turn crankshaft twice and check that crankshaft and camshaft marks are aligned with proper reference points
- check ignition timing and if necessary, adjust

Volkswagen Corrado 1990 - 1994
General Engine
Engine - Crankshaft, Crankcase (Page 13-9)

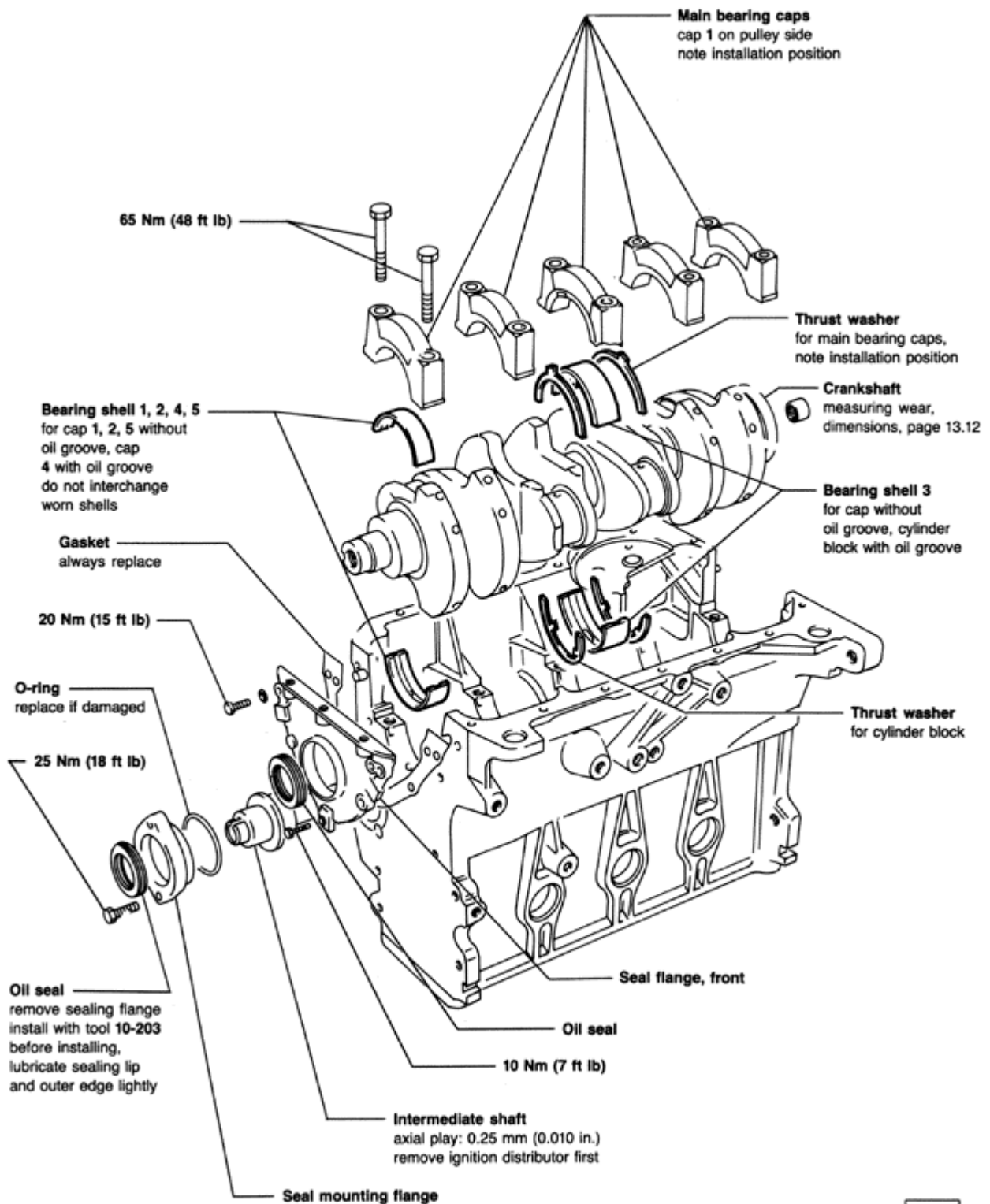

Volkswagen Corrado 1990 - 1994
General Engine
Engine - Crankshaft, Crankcase (Page 13-10)

WARNING!

Friction materials such as brake and clutch linings, or brake pads may contain asbestos fibers.

Do not create dust by grinding, sanding or by cleaning with compressed air.

Avoid breathing asbestos fibers and asbestos dust.

Breathing asbestos may result in serious diseases, such as asbestosis or cancer.

It may cause severe injury and death.

Repairing clutch, see [Repair Group 30](#)

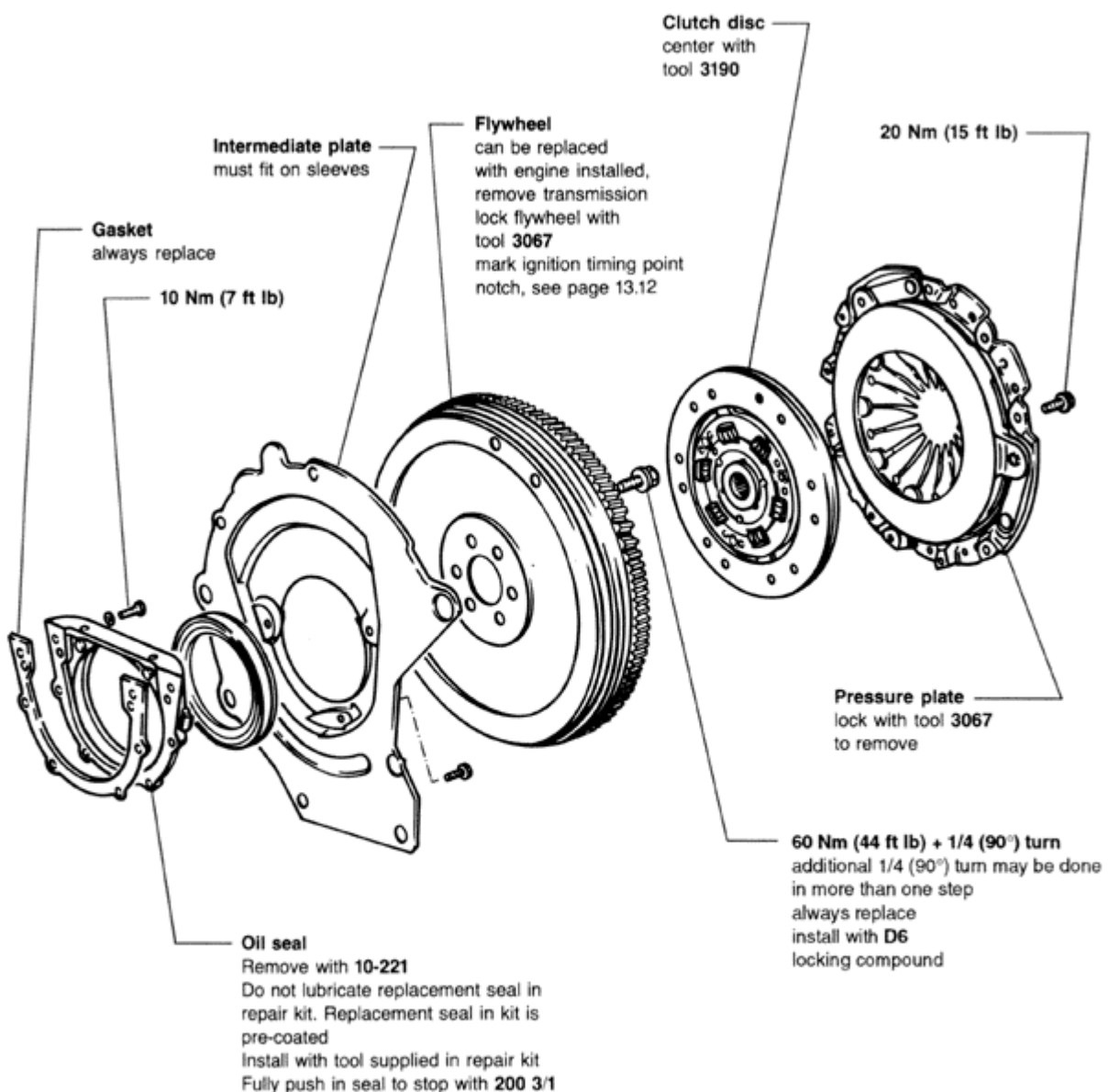

Crankshaft oil seal - drive belt side, removing

- remove drive belt
- remove drive belt sprocket (use socket **3099** to loosen mounting bolts) (**arrow**)

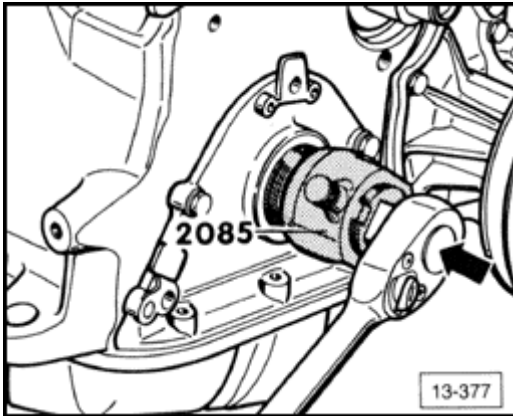

A

- unscrew inner part of oil seal extractor **2085** two turns (approximately 3 mm) out of outer part and lock with knurled screw
- to guide extractor, insert cylinder bolt from **3083** into crankshaft until it stops
- lubricate threaded head of oil seal extractor, set in position and push as far as possible into oil seal
- loosen knurled screw and turn inner part against crankshaft until oil seal is pulled out
- clamp extractor in a vise and remove oil seal using pliers

Crankshaft oil seal - drive belt side, installing

- lightly lubricate sealing lip and outer edge of new oil seal

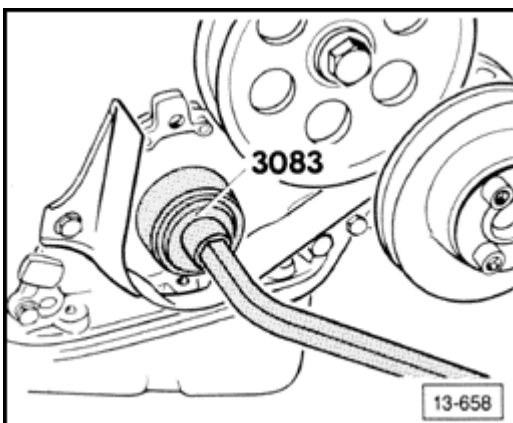

A

- place guide sleeve from **3083** onto crankshaft pin and push oil seal over guide sleeve
- press in oil seal up to stop
- reinstall drive belt

Crankshaft dimensions (mm)

	Main bearing journal (mm)	Connecting rod journal (mm)
Basic dimension	53.958-53.978	47.758-47.778
1st undersize	53.608-53.728	47.758-47.778
2nd undersize	53.458-53.478	47.258-47.278
3rd undersize	53.208-53.228	47.008-47.028

Making ignition timing mark

Notes

If you replace the flywheel/drive plate you will have to inscribe the ignition timing mark. Replacement flywheel/drive plates have the 0 degree TDC mark only.

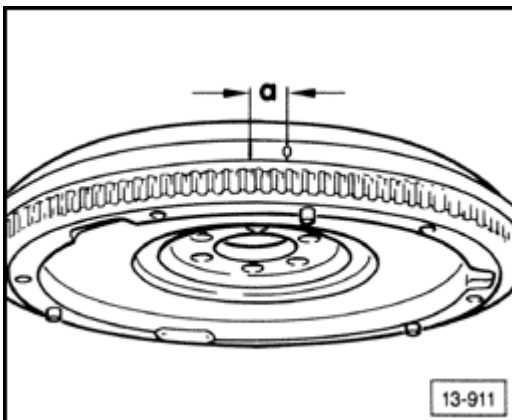

A

Make ignition timing mark at a point in an arc left from center of TDC marking.

- $a = 14.5 \text{ mm}$ (37/64 in.) along arc

Volkswagen Corrado 1990 - 1994
 General Engine
 Engine - Crankshaft, Crankcase (Page 13-13)

CAUTION!

Do not turn crankshaft when measuring radial play.

CAUTION!

Connecting rod bolts may be reused only once when checking radial play with engine installed. After checking radial play mark each bolt on thread side with center punch to show bolt was used once already.

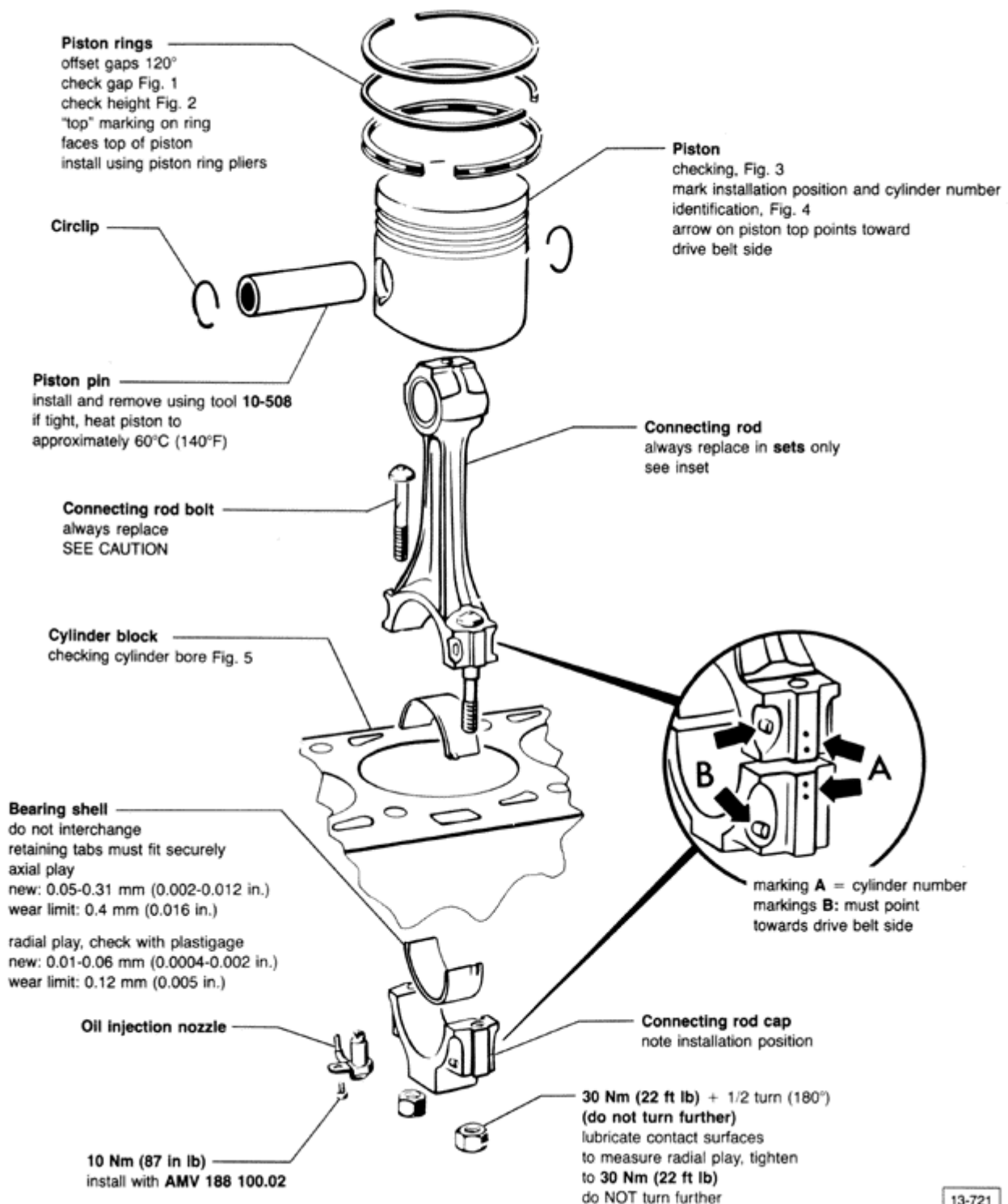

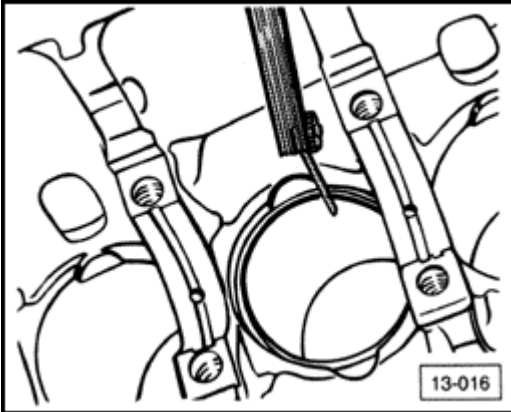

▲

Fig. 1 Piston rings, checking end gap

- insert piston ring squarely into cylinder until it is approximately 15 mm (19/32 in.) from bottom edge of cylinder

New

- compression ring: 0.15-0.35 mm
(0.006-0.014 in.)
- oil scraper ring: 0.25-0.50 mm
(0.01-0.020 in.)

Wear limit:

- 1.0 mm (0.04 in.)

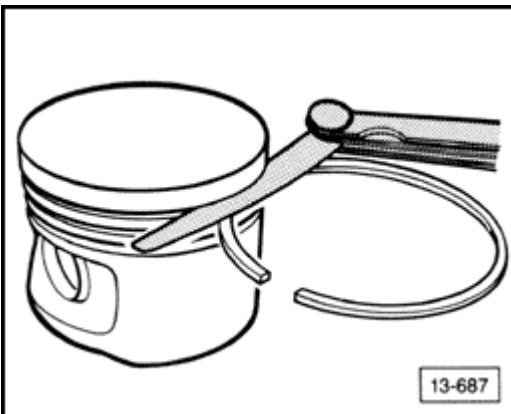

▲

Fig. 2 Piston ring side clearance, checking

New:

- compression ring: 0.02-0.07 mm
(0.001-0.003 in.)
- oil scraper ring: 0.02-0.06 mm
(0.001-0.002 in.)

wear limit:

- 0.15 mm (0.006 in.)

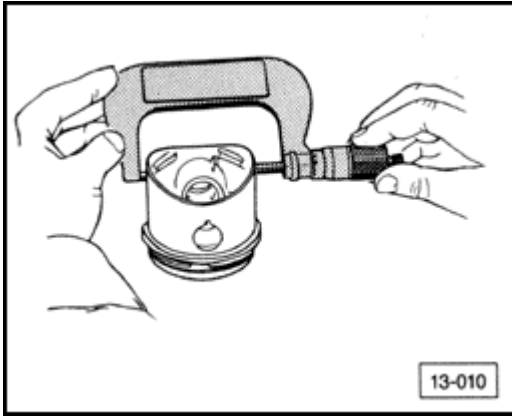

A

Fig. 3 Piston, checking

- measure approximately 10 mm (25/64 in.) from lower edge of skirt at 90° angle to piston pin axis

Nominal dimension tolerance:

- maximum 0.04 mm (0.0016 in.)

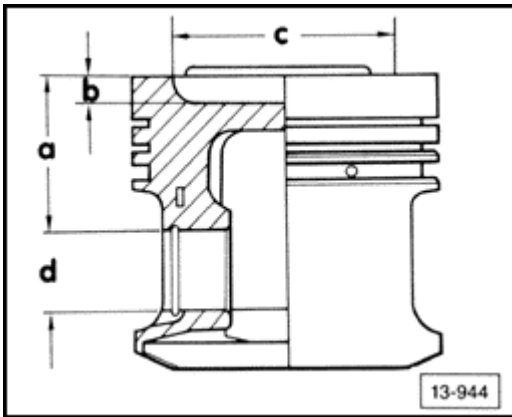

A

Fig. 4 Piston identification (mm)

a = 28.5

b = 8.6

c = 55.0

d = 22.0

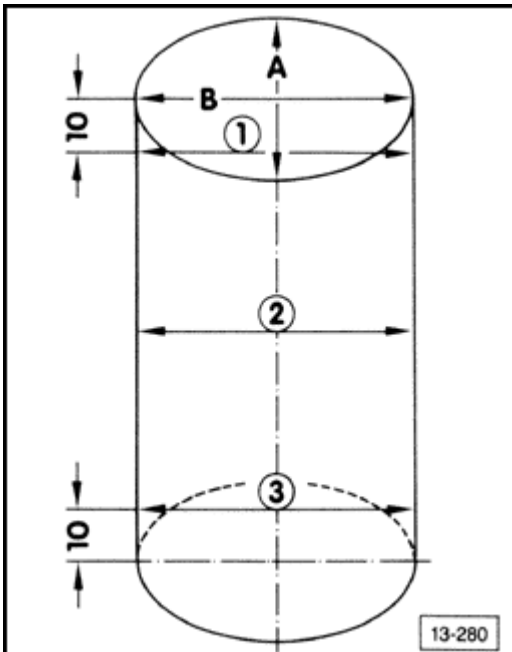

A

Fig. 5 Cylinder bore, checking

- measure at three points in cross direction **A** and longitudinal direction **B**

Use inside micrometer 50-100 mm (2 to 4 inches).

Maximum deviation from nominal dimension:

- 0.08 mm (0.003 in.)

CAUTION!

Do not measure cylinder bore when cylinder block is mounted to work bench with engine mount VW 540 . Engine mounted in fixture can cause distortion affecting measurement.

Piston and cylinder dimensions (mm)

Size	Piston	Cylinder bore
Standard	80.985 mm	81.01 mm
1st oversize	81.23 mm	81.26 mm
2nd oversize	81.48 mm	81.51 mm

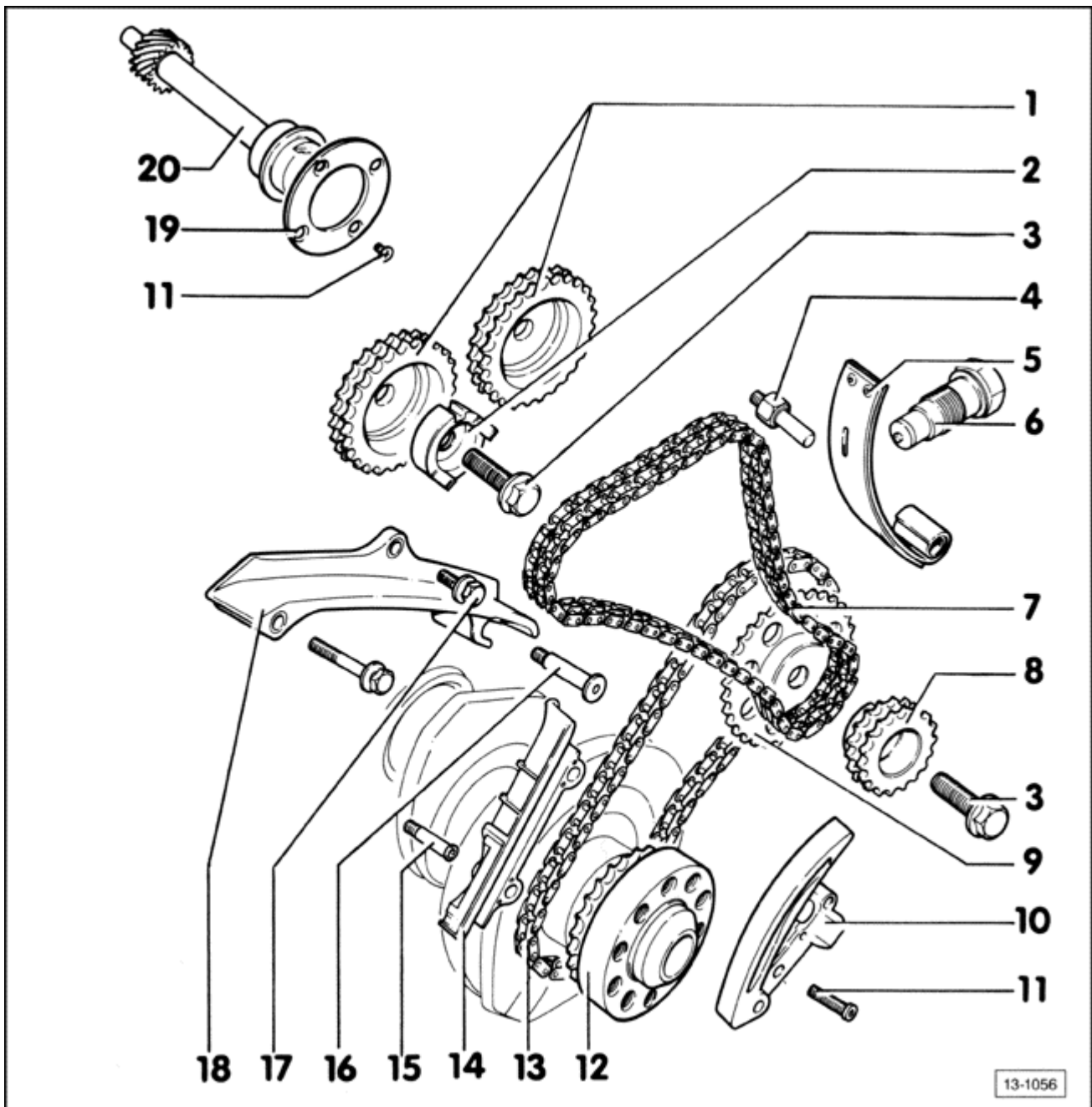

CAUTION!

Coolant/anti-freeze must not be reused when replacing engine, cylinder head, cylinder head gasket, radiator and heater core.

CAUTION!

Always replace gaskets and seals, with exception of camshaft cover or sealing flange, see [page 13-19](#).

WARNING!

DO NOT re-use any fasteners that are worn or deformed in normal use. Many fasteners are designed to be used only once and become unreliable and may fail when used a second time. This includes, but is not limited to, nuts, bolts washers, self-locking nuts or bolts, circlips, cotter pins. Always follow recommendations given in this publication. For replacements always use new parts.

1 - Camshaft sprockets

Removing, see [Repair Group 15](#)

2 - Distributor drive

3 - Bolt - 100 Nm (74 ft lb)

Volkswagen Corrado 1990 - 1994
General Engine
Engine - Crankshaft, Crankcase (Page 13-17)

4 - Pivot pin - 25 Nm (18 ft lb)

5 - Tensioning plate

6 - Tensioner - 20 Nm (15 ft lb)

7 - Double drive chain

note direction of travel, see [page 13-18](#)

8 - Sprocket, double drive chain

9 - Sprocket, single drive chain

10 - Chain tensioner with plate

11 - Bolt - 10 Nm (7 ft lb)

12 - Drive sprocket

- installed on crankshaft
- ground down tooth on bearing groove points toward **TDC** cylinder 1
- installing chain tensioner with plate, see [page 13-24a](#)

13 - Single drive chain

note direction of travel, see [page 13-18](#)

14 - Guide rail

15 - Retaining bolt - 25 Nm (18 ft lb)

16 - Locating pin w/collar - 25 Nm (18 ft lb)

17 - Bolt - 20 Nm (15 ft lb)

18 - Guide rail

19 - Guide ring

20 - Intermediate shaft

Drive chains, marking direction of travel

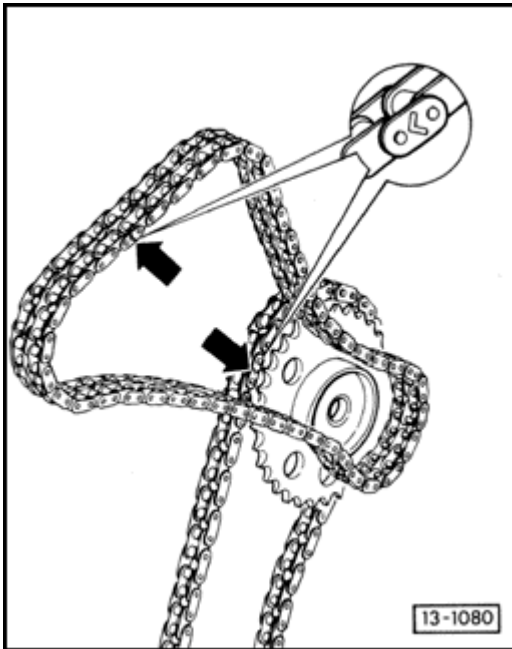

- using touch-up paint, mark direction of travel of drive chains before removing (arrow)

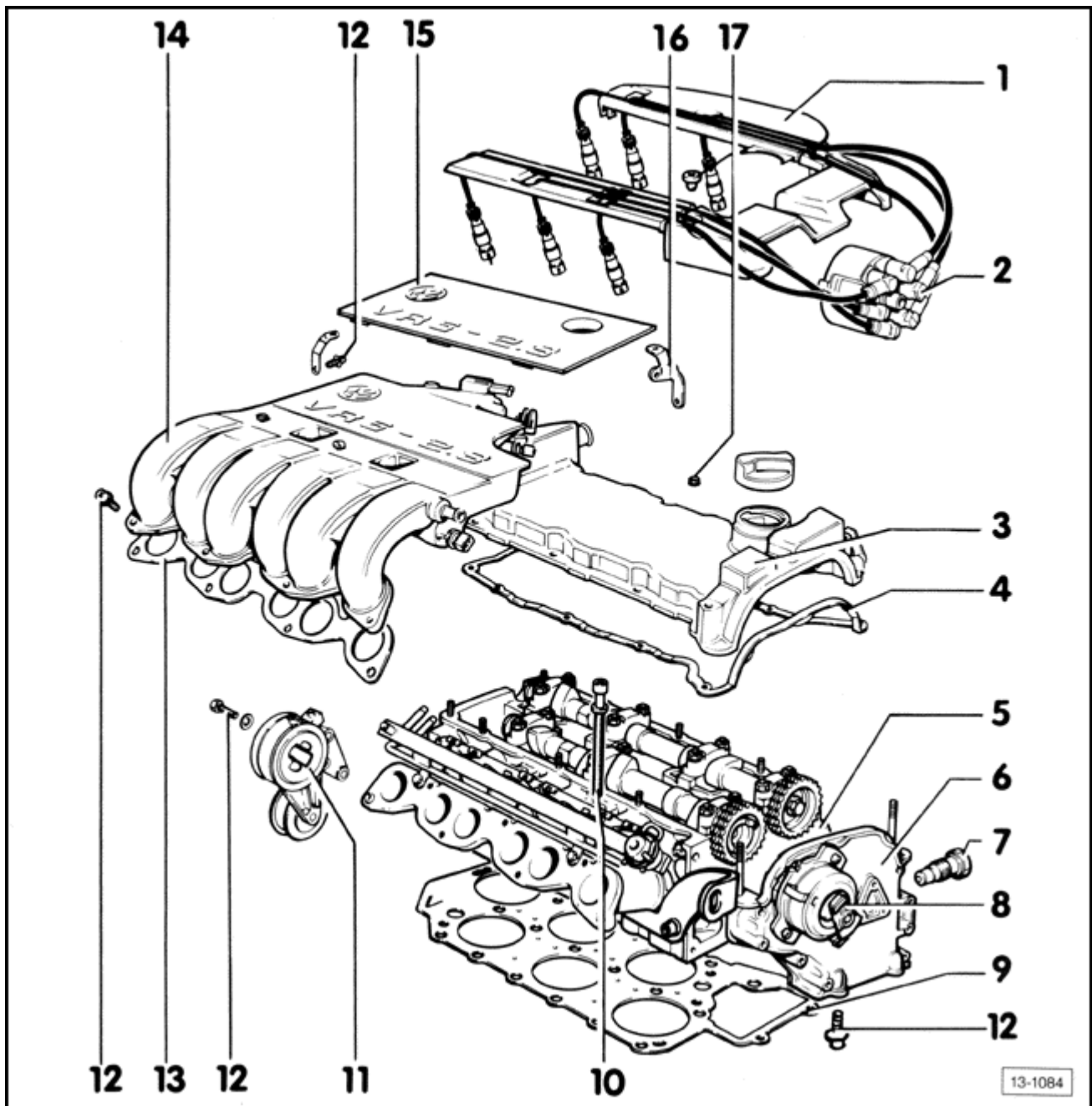

CAUTION!

Coolant/anti-freeze must not be reused when replacing engine, cylinder head, cylinder head gasket, radiator and heater core.

CAUTION!

Always replace gaskets, O-rings, and seals.

CAUTION!

Part numbers are for reference only. Always check with your Parts Department for latest information.

- 1 - Ignition wire guide
- 2 - Ignition distributor cap, with ignition wires
- 3 - Cylinder head cover

4 - Cylinder head cover seal

- note position when reinstalling
- always replace

5 - Cylinder head

removing/installing, see [Repair Group 15](#)

6 - Camshaft sprocket cover

coat sealing surface with **AMV 188 001 02**

7 - Tensioner bolt for double drive chain -20 Nm (15 ft lb)

Volkswagen Corrado 1990 - 1994
General Engine
Engine - Crankshaft, Crankcase (Page 13-20)

8 - Ignition distributor

replacing rotor, see Repair Group 28

9 - Cylinder head gasket

- install so that word "TOP" faces cylinder head
- always replace

10 - Cylinder head bolts

- torque and tightening sequence, see [Repair Group 15](#)
- always replace

11 - Tension roller, poly-ribbed belt

removing/installing poly-ribbed belt, see [page 13-25](#)

12 - Bolt - 25 Nm (18 ft lb)

13 - Upper intake manifold gasket

always replace

14 - Intake manifold, upper

installing: tighten lower intake manifold, then intake manifold support **16**

15 - Trim cover

16 - Intake manifold support

17 - 10 Nm (7 ft lb)

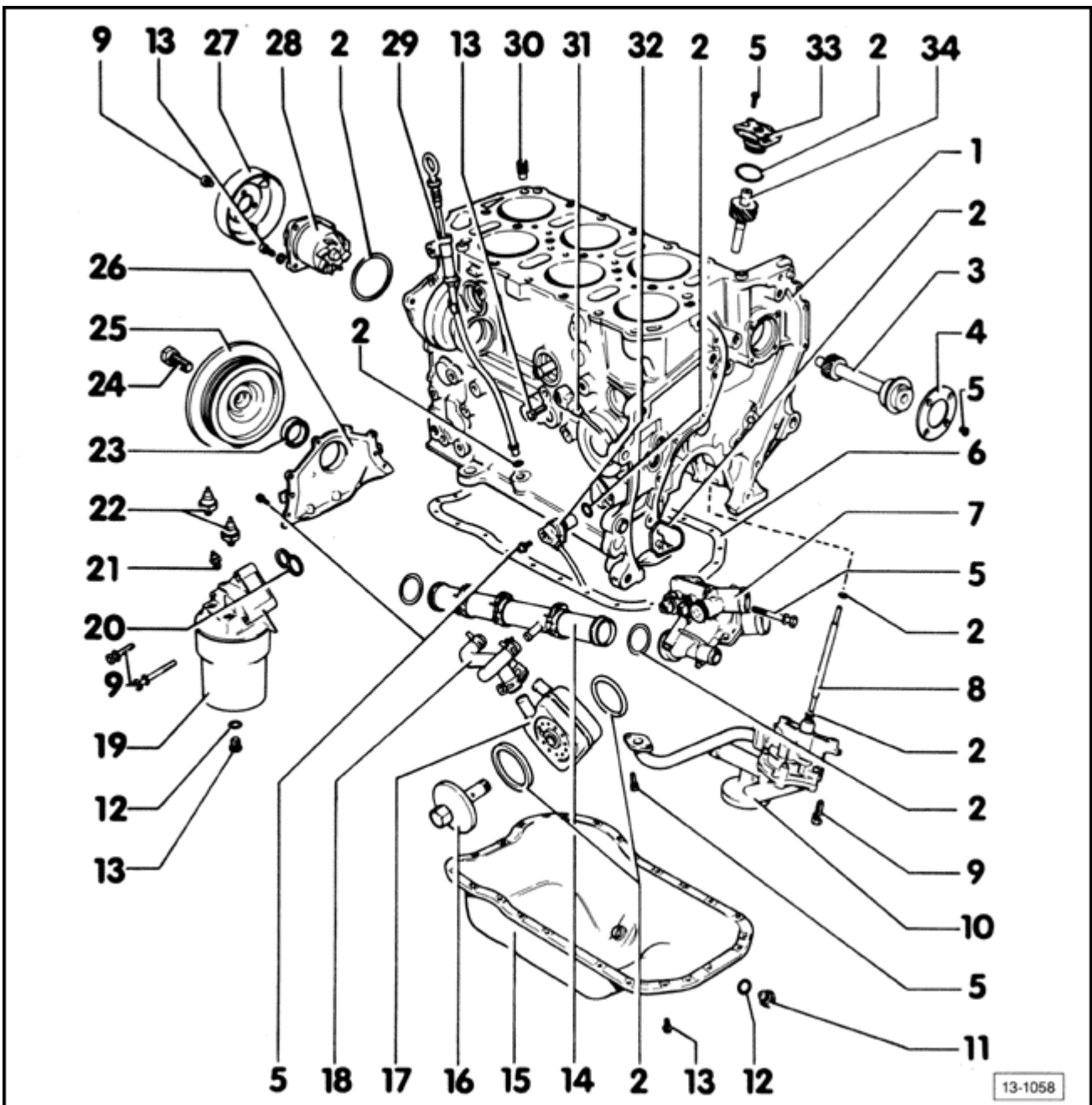

CAUTION!

Coolant/anti-freeze must not be reused when replacing engine, cylinder head, cylinder head gasket, radiator and heater core.

CAUTION!

Always replace gaskets and seals.

CAUTION!

If metal shavings are found in the engine oil as a result of engine damage; clean oil passages thoroughly, then replace all oil spray jets, oil pressure relief valve, oil cooler and oil filter.

CAUTION!

Part numbers are for reference only. Always check with your Parts Department for latest information.

1 - Cylinder block

2 - O-ring

always replace

3 - Intermediate shaft

4 - Thrust washer

5 - 10 Nm (7 ft lb)

Volkswagen Corrado 1990 - 1994

General Engine

Engine - Crankshaft, Crankcase (Page 13-22)

6 - Oil pan gasket

- before installing, coat sealing flange/cylinder block with **AMV 188 001 02**
- always replace

7 - Thermostat housing

8 - Oil pump driveshaft

9 - Bolt - 25 Nm (18 ft lb)

remove and install pulley 27 with tool **VAG 1590**

10 - Oil pump

assembling/disassembling, see [Repair Group 17](#)

11 - Oil drain plug - 50 Nm (37 ft lb)

12 - Gasket

always replace

13 - Bolt - 20 Nm (15 ft lb)

14 - Coolant pipe w/drain plug

15 - Oil pan

16 - Cover, oil cooler - 25 Nm (18 ft lb)

17 - Oil cooler

- coat seal surface with **AMV 188 001 02**
- ensure adequate side clearance

18 - Coolant hose to crankcase

19 - Oil filter housing - 30 Nm (22 ft lb)

removing/installing, see [Repair Group 17](#)

20 - O-ring

- note installation position
- always replace

21 - Oil temperature sender - 10 Nm (7 ft lb)

22 - 22 - Oil pressure switch - 25 Nm (18 ft lb)

checking, see [Repair Group 17](#)

23 - Crankshaft oil seal, drive belt side

removing/installing, see [page 13-26](#)

24 - 100 Nm (74 ft lb) + 1/4 (90°) turn

- use support bracket 3273 when loosening/tightening vibration dampener
- always replace

25 - Vibration dampener

26 - Sealing flange

coat sealing surface with **AMV 188 001 02**

27 - Coolant pump pulley

28 - Coolant pump

removing/installing, see [Repair Group 19](#)

29 - Dipstick w/guide tube 30 - Oil pressure relief valve - 5 Nm (44 in.lb)

- note installation position
- replace if badly contaminated

31 - Knock sensor 2 (G66) - 20 Nm (15 ft lb)

- torque has influence on operation of knock sensor
- torque specifications must be strictly adhered to
- do **NOT** install with spring washer or equivalent

32 - Speed/reference Sender (G28)

33 - Oil pump drive cover

coat O-ring with engine oil before installing

34 - Oil pump drive

Valve timing, checking and adjusting

Vehicles with manual transmission

With engine installed:

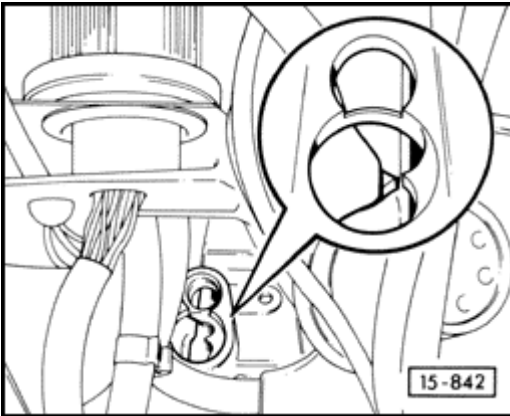

- rotate engine until piston for cylinder 1 is at **TDC**
 - starting with 11-91 production, note 3 cornered tooth (formerly had a rounded tooth)

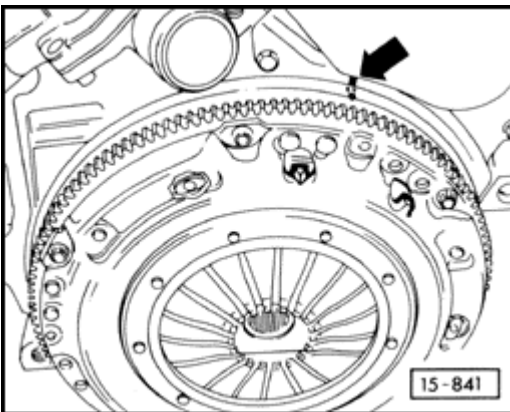

With engine removed

- align casting on sealing flange with **TDC** marking on flywheel
- remove ignition wire guides
- remove intake manifold upper section
- remove valve cover

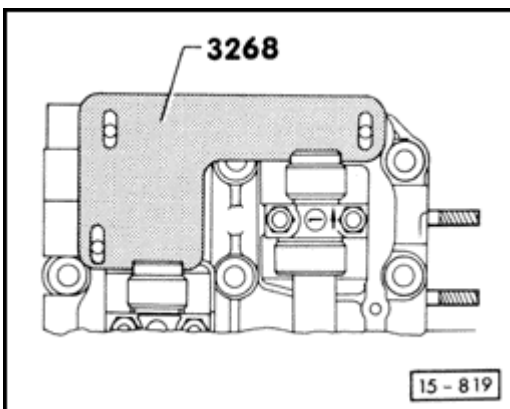

- install and align **3268** camshaft guide onto cylinder head studs with both camshafts

snugly positioned in the guide indentations (as shown)

Vehicles with automatic transmission

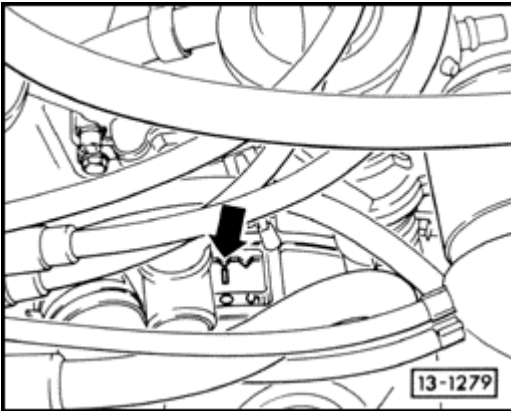

With engine installed:

- rotate engine until piston for cylinder 1 is at **TDC**

CAUTION!

There are three marks for cylinder 1 TDC on the torque convertor spaced in 120° intervals. To be sure the engine is actually at TDC it is mandatory that you verify this condition via the cylinder 1 spark plug hole.

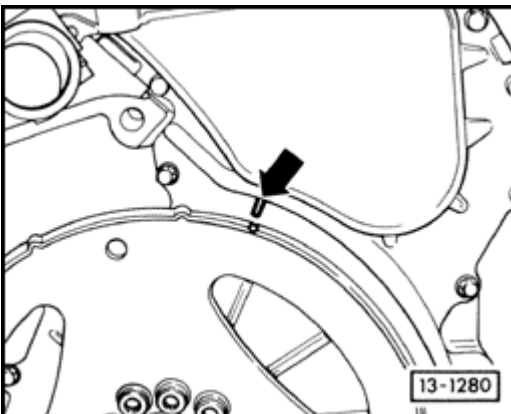

With engine removed:

- align the **TDC** marking on the converter mounting plate with the mark on the flange
- remove ignition wire guides
- remove intake manifold upper section
- remove valve cover

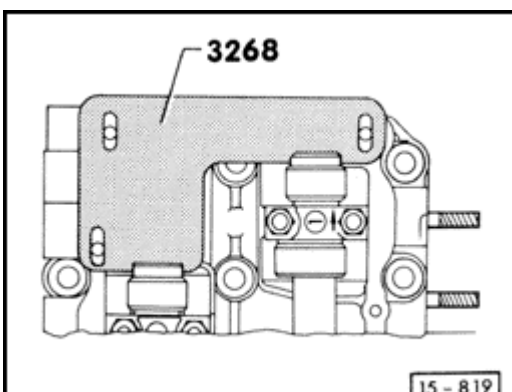

- install and align **3268** camshaft guide onto cylinder head studs with both camshafts snugly positioned in the guide indentations (as shown)
- this alignment is only possible every 2nd engine revolution

Timing chains, installing

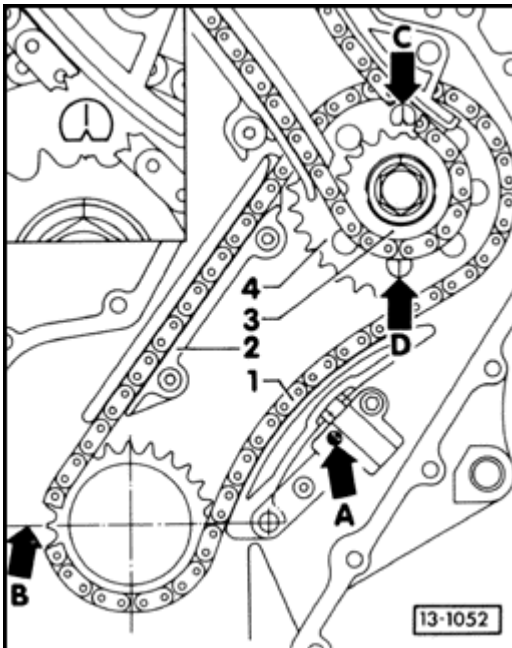

- check position of crankshaft with reference to intermediate shaft
 - ground tooth of drive gear **B** must align with bearing split, re-position if necessary
- install guide rail **2**
- install chain **1** and intermediate shaft gears **3** and **4**
 - note direction of chain rotation, see [page 15-28](#)
 - marking on intermediate shaft **4** must align with notch **C** or **D** on the thrust washer
- unlatch lock gear in chain tensioner using a small screwdriver **A**
 - this relaxes the chain tensioner providing additional play for chain routing
- tighten intermediate shaft gears **3** and **4**
 - tighten to 100 Nm (74 ft lb)

To prevent the engine from turning while tightening the shaft gears (Manual transmission):

- fasten flywheel/driving plate to the crankshaft with at least 3 bolts and lock in place with holding tool **VW 558**

To prevent the engine from turning while tightening the shaft gears (Automatic transmission):

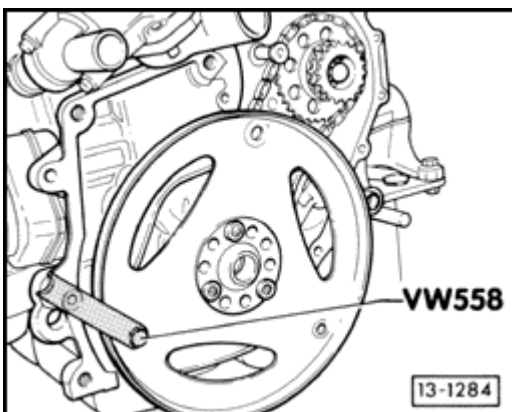

- fasten drive plate to engine using holding tool **VW 558**

- use an **M8 x 45 bolt**
- place 2 **M10** hex nuts between the holding tool and the drive plate

Volkswagen Corrado 1990 - 1994
General Engine
Engine - Crankshaft, Crankcase (Page 13-24b)

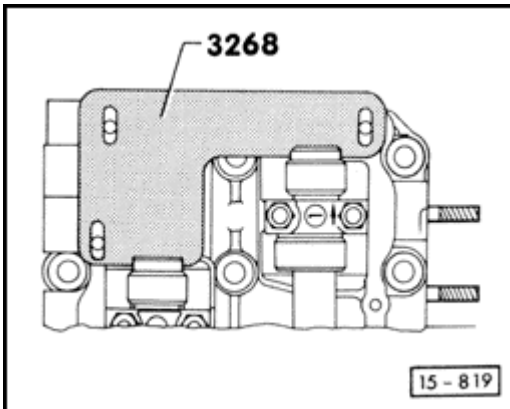

- position the camshafts in the cylinder head using the **3268** camshaft guide
 - with the cylinder head removed
- install cylinder head, see [Repair Group 15](#)
- install tensioning rail for chain tensioner
 - dual roller chain
- position rail on both bearing bolt and cylinder head
- position dual roller chain on intermediate shaft gear
 - note previously marked run direction
- attach camshaft chain gear and dual roller chain to the shorter camshaft (cylinders **2**, **4** and **6**) using distributor connector and hand tighten
- attach camshaft chain gear and dual roller chain to the longer camshaft (cylinders **1**, **3** and **5**) and hand tighten
- remove **3268** camshaft guide
- tighten camshaft chain gears
 - tightening torque: 100 Nm (74 ft lb)

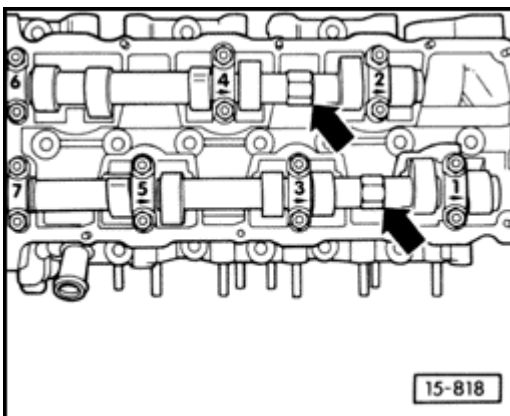

- use a 24mm wrench on hexes (**arrows**) to prevent camshaft rotation while torquing drive gears

CAUTION!

DO NOT have the 3268 camshaft guide installed while tightening the camshaft gears.

- coat flange sealing surface with **AMV 18800102** and install
- prepare cylinder head gasket for installation, see [Repair Group 15](#)

- coat valve cover sealing surface with **AMV 18800102** and insert sealing ring
- install front camshaft cover
- tighten chain tensioner
- rotate crankshaft two full turns in direction of engine rotation and stop when in cylinder **1 TDC** position

CAUTION!

DO NOT rotate the engine unless the chain tensioner is tightened; otherwise, the control chain will jump out.

Volkswagen Corrado 1990 - 1994
General Engine
Engine - Crankshaft, Crankcase (Page 13-24c)

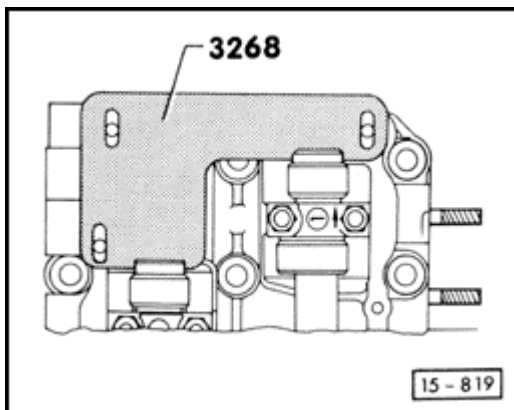

- install and align **3268** camshaft guide onto cylinder head studs with both camshafts snugly positioned in the guide indentations (as shown)
 - this alignment is only possible every 2nd engine revolution

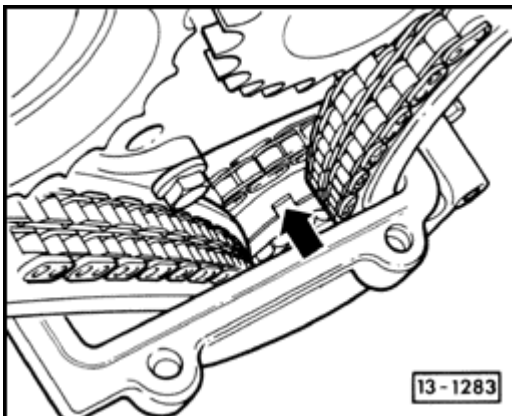

With engine installed and cylinder head removed

- rotate engine until piston for cylinder **1** is in **TDC** position
- when piston is at **TDC** , a notch (**arrow**) should be visible on the intermediate shaft chain gear

If the notch is not visible

- turn crankshaft one complete revolution in direction of normal running rotation

Notes

If the engine is rotated with the cylinder head removed, a second mechanic is required to guide the dual roller chain to prevent it from hanging up.

- position the camshaft in the cylinder head using the **3268** camshaft guide
- fill the 3 mm holes in the cylinder head gasket with **AMV 18800102** sealant
- cylinder head assembling, see [Repair Group 15](#)
- insert rail on bearing bolt and bolt to cylinder head
- attach camshaft chain gear and dual roller chain to the shorter camshaft (cylinders **2**, **4** and **6**) using distributor connector and hand tighten
- attach camshaft chain gear and dual roller chain to the longer camshaft (cylinders **1**, **3** and **5**) and hand tighten
- remove camshaft **3268** camshaft guide
- tighten camshaft chain gear

- tightening torque: 100 Nm (74 ft lb)

Volkswagen Corrado 1990 - 1994
General Engine
Engine - Crankshaft, Crankcase (Page 13-24d)

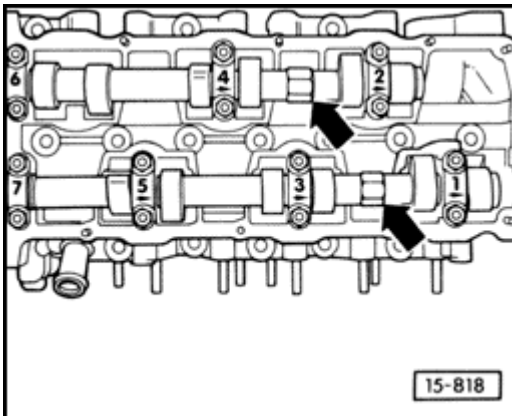

- use a 24mm wrench on hexes (**arrows**) to prevent camshaft rotation while torquing drive gears

CAUTION!

DO NOT have the 3268 camshaft guide installed while tightening the camshaft gears.

- prepare cylinder head gasket for installation, see [Repair Group 15](#)
- coat valve cover sealing surface with, **AMV 18800102** and insert sealing ring
- install front camshaft cover
- tighten chain tensioner
- rotate crankshaft two full turns in direction of engine rotation and stop when in cylinder 1 TDC position

CAUTION!

DO NOT rotate the engine unless the chain tensioner is tightened; otherwise, the control chain will jump out.

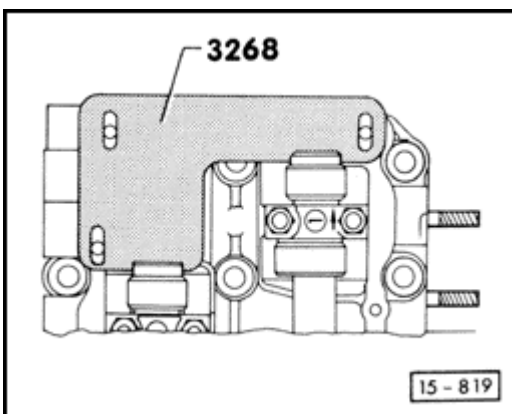

- install and align **3268** camshaft guide onto cylinder head studs with both camshafts snugly positioned in the camshaft guide indentations (as shown)
 - this alignment is only possible every 2nd engine revolution

Poly-ribbed belt, removing/installing

Removing

- remove air cleaner housing

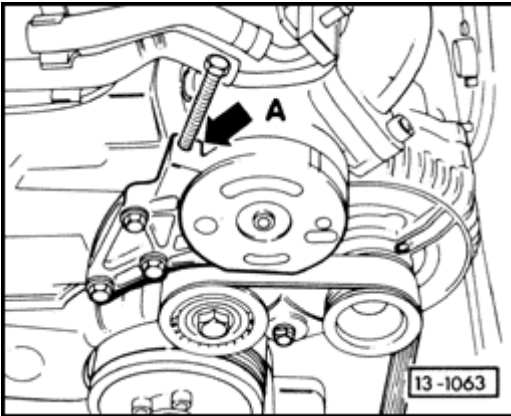

- insert a long (M 8 x 80) bolt into threaded hole **A** on tensioner
- screw in bolt until poly-ribbed belt is loose

Notes

Only screw in bolt until belt is loosened. Screwing bolt further will damage tensioner.

- remove poly-ribbed belt

Installing

Notes

Before reinstalling belt, ensure all belt driven components, such as alternator, A/C compressor and power steering pump are installed.

Ensure correct mounting of poly-ribbed belt on all pulleys and rollers.

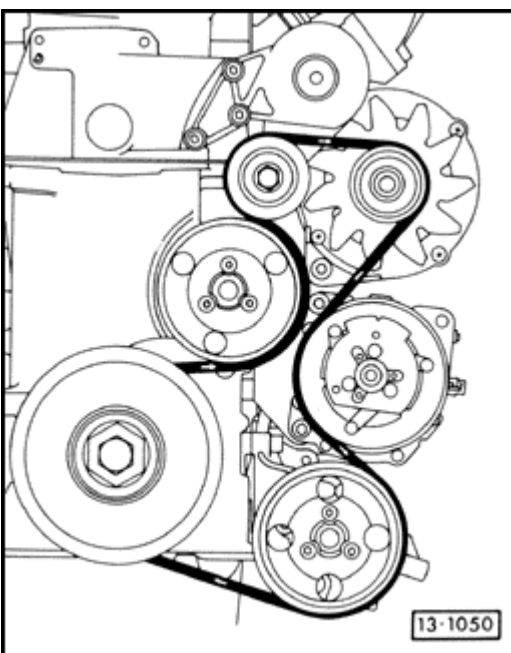

- reinstall and route poly-ribbed belt as shown
- remove bolt from tensioner
-

start engine

- ensure belt runs properly

Notes

Vehicles with air conditioning are equipped with a double ribbed belt.

Crankshaft oil seal - drive belt side, removing/installing

Removing

- remove poly-ribbed belt
- using support bracket **3273** , remove vibration dampener
- unscrew inner part of oil seal extractor **3203** three turns (approximately 4.0 mm) out of outer part and lock in position with knurled screw
- lubricate threaded head of oil seal extractor, set in position and push as far as possible into oil seal
- loosen knurled screw and turn inner part against crankshaft until oil seal is pulled out
- clamp extractor in a vise and remove oil seal using pliers

Installing

- lightly lubricate sealing lip and outer edge of new oil seal

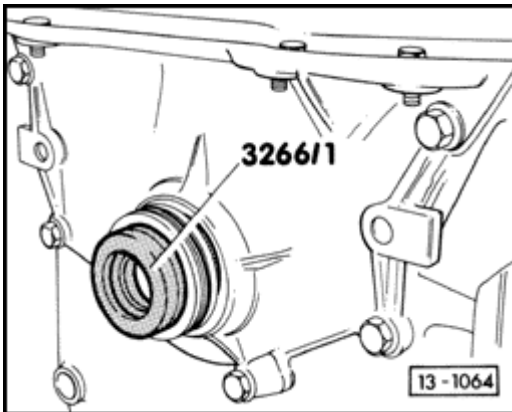

- place guide sleeve from **3266/1** onto crankshaft pin and push oil seal over guide sleeve

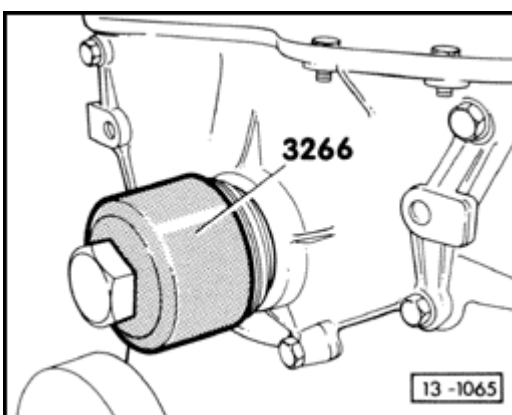

- using vibration dampener securing bolt, press in oil seal with sleeve **3266** up to stop
- using support bracket **3273** , reinstall vibration dampener
 - torque 450 Nm (328 ft lb)
- reinstall poly-ribbed belt

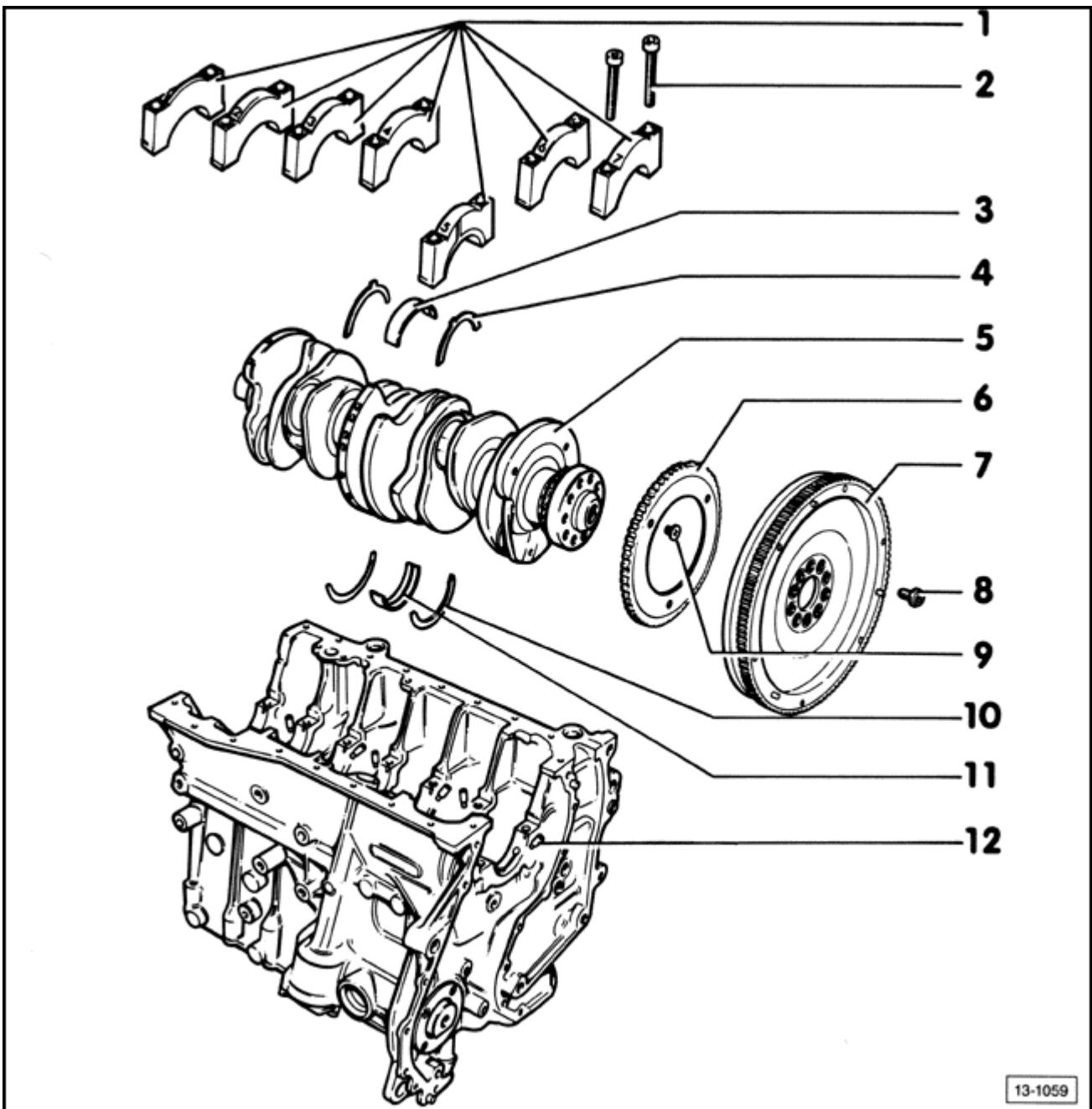

1 - Main bearing caps

- cap 1 on drive belt side
- note installation position

2 - 30 Nm (22 ft lb) + 1/2 (180°) turn

Additional 1/2 (180°) turn may be done in two 90° steps

3 - Bearing shells 1-7

for main bearing caps

4 - Thrust washer

- for bearing 5
- note installation position in bearing cap

5 - Crankshaft

- end play:
New: 0.07-0.17 mm (0.003-0.007 in.)
Wear limit: 0.25 mm (0.01 in.)
- radial play: check with Plastigage©
New: 0.02-0.06 mm (0.001-0.002 in.)
Wear limit: 0.10 mm (0.004 in.)

6 - Toothed wheel

- for Engine Speed/Reference Sensor (**G 28**)
- always replace

7 - Flywheel

hold flywheel with tool **VW 558** when removing

8 - 60 Nm (44 ft lb) + 1/4 (90°) turn

- always replace

Volkswagen Corrado 1990 - 1994
General Engine
Engine - Crankshaft, Crankcase (Page 13-28)

9 - 10 Nm (7 ft lb) + 1/4 (90°) turn

always replace

10 - Thrust washer for bearing 5

- for cylinder block
- note installation position

11 - Bearing shells 1-7

- for cap with oil groove
- do **NOT** interchange worn shells
- for cylinder block

12 - Oil spray jet

- removing installing, see [Repair Group 17](#)
- see **CAUTION!** [page 13-21](#)

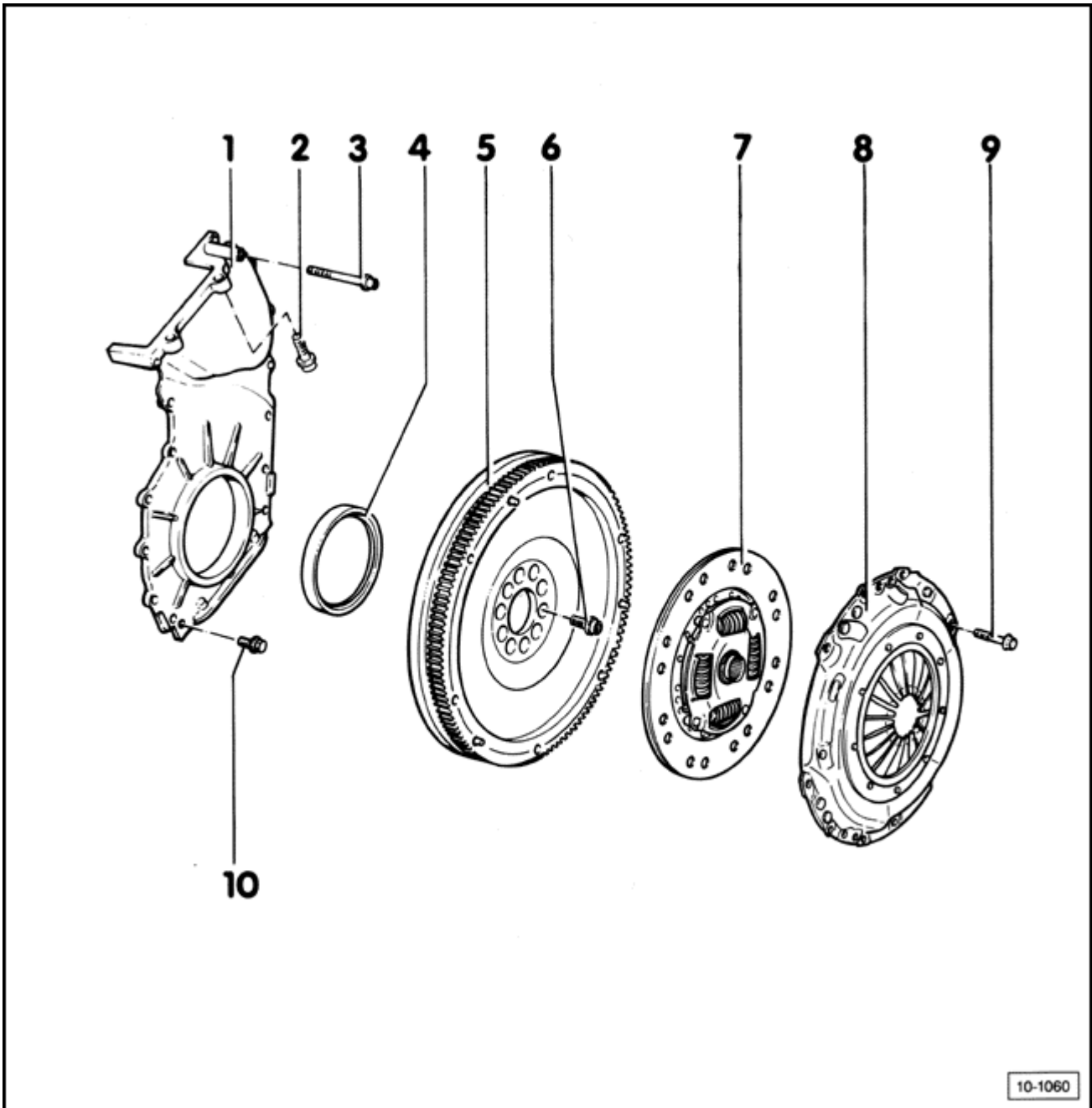

CAUTION!

Friction materials such as brake and clutch linings, or brake pads may contain asbestos fibers.

Do NOT create dust by grinding, sanding or by cleaning with compressed air.

Avoid breathing asbestos fibers and asbestos dust.

Breathing asbestos may result in serious diseases, such as asbestosis or cancer.

It may cause severe injury and death.

CAUTION!

Part numbers are for reference only. Always check with your Parts Department for latest information.

1 - Seal flange

- coat sealing surface with **AMV 188 001 02**

- if flange has been removed, check and prepare cylinder head seal, see [Repair Group 15](#)

2 - 25 Nm (18 ft lb)

Volkswagen Corrado 1990 - 1994
General Engine
Engine - Crankshaft, Crankcase (Page 13-30)

3 - 10 Nm (7 ft lb)

4 - Oil seal

- remove with tool **2086**
- installing: lightly lubricate sealing lip and outer edge install with, pull sleeves from tool **2003/2A** press in seal to stop with tool **2003/1**

5 - Flywheel

- can be replaced with engine installed
- removing 5-speed transmission, see [Repair Group 34](#)
- hold flywheel with tool **558** when removing

6 - 60 Nm (44 ft lb) + 1/4 (90°) turn

- always replace

7 - Clutch disc

center with tool **3190 A**

8 - Pressure plate

- when removing, hold flywheel with tool **558**
- note installed position with **TDC** marking for No. 1 cylinder (rounded, ground down tooth)

9 - 20 Nm (15 ft lb)

tightly diagonally

10 - 10 Nm (7 ft lb)

Volkswagen Corrado 1990 - 1994
General Engine
Engine - Crankshaft, Crankcase (Page 13-31)

Crankshaft dimensions (in mm)

Wear limit	Crankshaft bearing journal diameter		Connecting rod journals diameter	
Standard	54.00	-0.022 -0.042	47.80	-0.022 -0.042
1st undersize	53.75	-0.022 -0.042	47.55	-0.022 -0.042
2nd undersize	53.50	-0.022 -0.042	47.30	-0.022 -0.042
3rd undersize	53.25	-0.022 -0.042	47.05	-0.022 -0.042

Drive plate, removing and installing

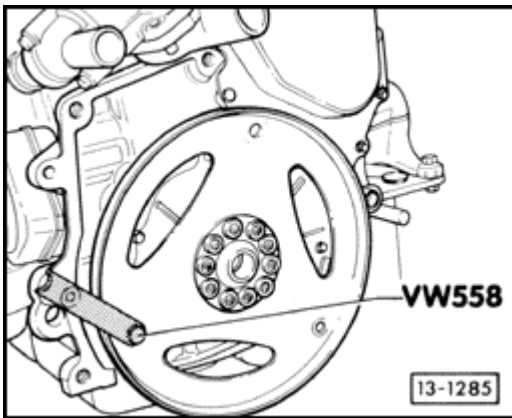

Loosening and tightening

- fasten holding tool **VW 558** to the drive plate using hex head bolt M8 x 45
 - insert 2 M10 hex nuts between holding tool and drive plate

Installing

- position drive plate to crankshaft and tighten using 3 used bolts
 - tighten to 30 Nm (22 ft lb)

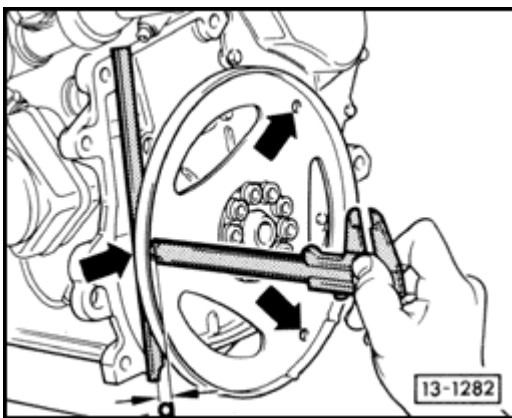

- measure "a" through the 3 torque converter mounting holes using a ruler and calculate the average dimension
 - the average dimension (measured distance + ruler thickness) must be between 15.7 and 16.5 mm

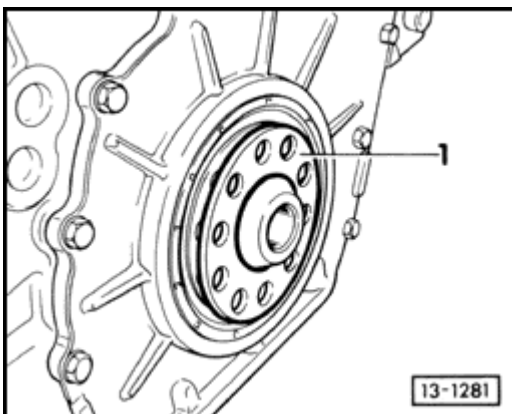

If average value is greater or less than specification

- remove drive plate and remount using used bolts again with the appropriate shims 1 to obtain the specification dimension

If OK

- remove used bolts
- fasten drive plate using new bolts
 - tighten to 60 Nm (44 ft lb) + 90° (1/4 additional turn)

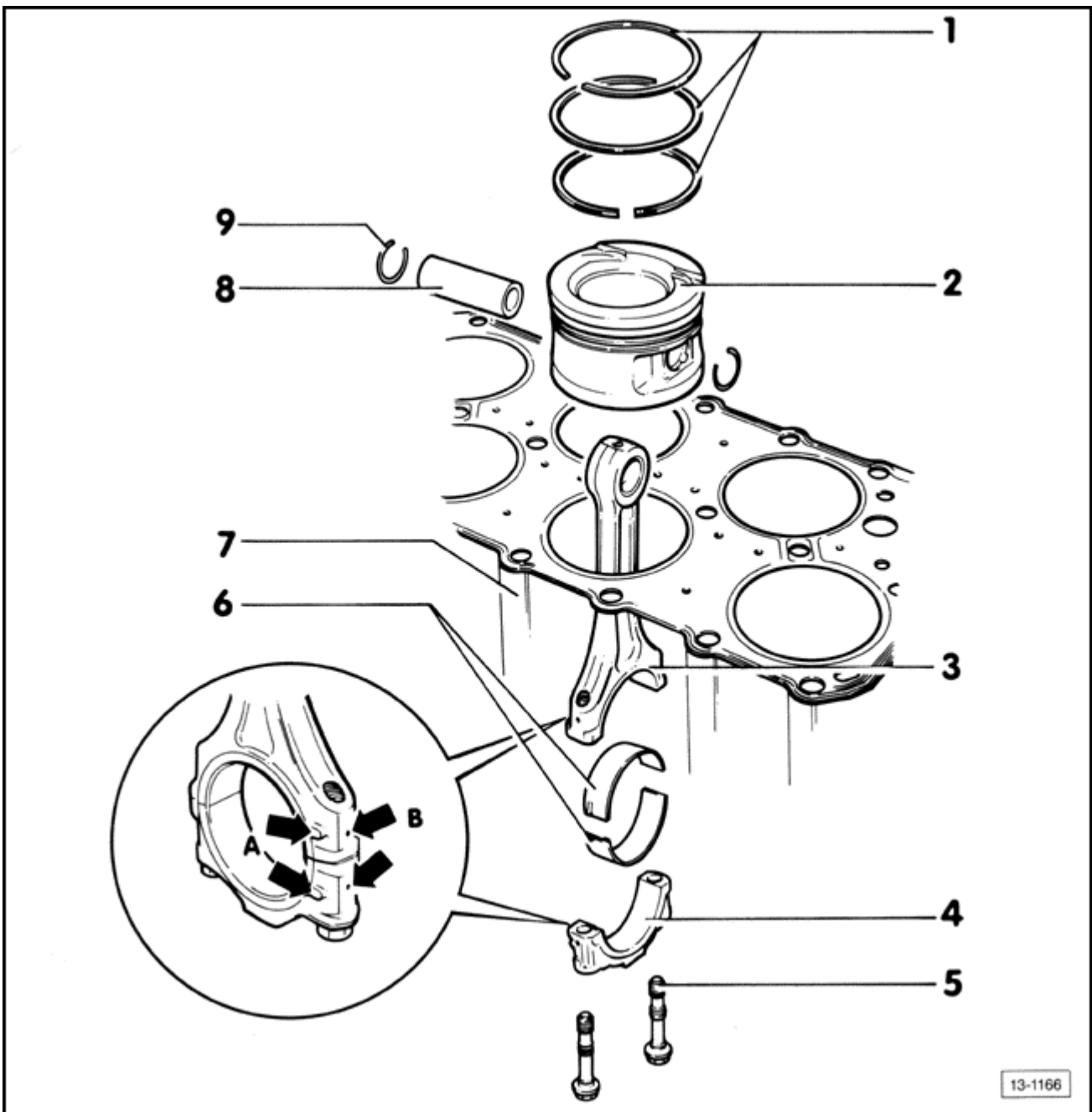

CAUTION!

Do NOT turn crankshaft when measuring radial play.

1 - Piston rings

- offset gaps 120
- remove/install using piston ring pliers
- "TOP" marking faces top of piston
- checking gap, see [page 13-34](#)
- checking side clearance, see [page 13-35](#)

2 - Piston

- checking, see [page 13-36](#)
- mark installation position and cylinder number

- highest side of piston crown is toward center of cylinder block
- install with tool **3278**

3 - Connecting rod

- replace in **sets** only
- markings **B (inset)** indicate cylinder number
- markings **A (inset)** must be on top of each other

4 - Connecting rod cap

note installation position

5 - Connecting rod bolt

- Use old bolts to check radial play, tighten to **30 Nm (22 ft lb)** , do **NOT** tighten further
- always replace
- new bolts tighten to **30 Nm (22 ft lb) + 1/4 (90°)** turn

Volkswagen Corrado 1990 - 1994

General Engine

Engine - Crankshaft, Crankcase (Page 13-33)

6 - Bearing shell

- note installation position
- do **NOT** interchange used bearing shells
- retaining **tabs** must fit securely
- end play,
 - New: 0.05-0.31 mm (0.002-0.012 in.)
 - Wear limit: 0.4 mm (0.016 in.)
- radial clearance, with Plastigage®,
 - New: 0.01-0.06 mm (0.0004-0.002 in.)
 - Wear limit: 0.10 mm (0.004 in.)

7 - Cylinder block

- checking cylinder bore, see [page 13-37](#)
- piston and cylinder dimensions, see [page 13-38](#)

8 - Piston pin

- remove and install with tool **VW 222a**
- if difficult to remove, heat piston to 60° C (140° F)

9 - Circlip

Piston rings, checking end gap

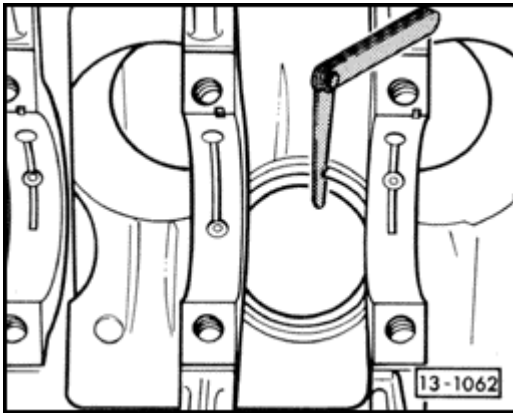

- insert piston ring squarely into cylinder
 - use a piston **without** rings to push
- push ring down until it is approximately 15 mm (19/32 in.) from bottom edge of cylinder

New:

- compression ring: 0.20-0.40 mm (0.008-0.056 in.)
- oil scraper ring: 0.25-0.50 mm (0.010-0.020 in.)

Wear limit:

- 1.0 mm (0.04 in.)

Piston ring side clearance, checking

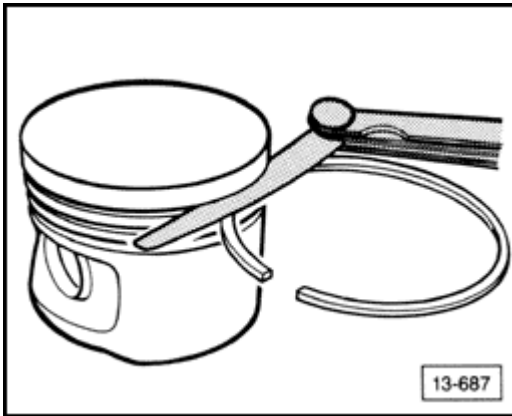

- clean groove before checking

New:

- compression ring: 0.02-0.07 mm (0.001-0.003 in.)
- oil scraper ring: 0.02-0.06 mm (0.001-0.002 in.)

Wear limit:

- 0.15 mm (0.006 in.)

Piston, checking

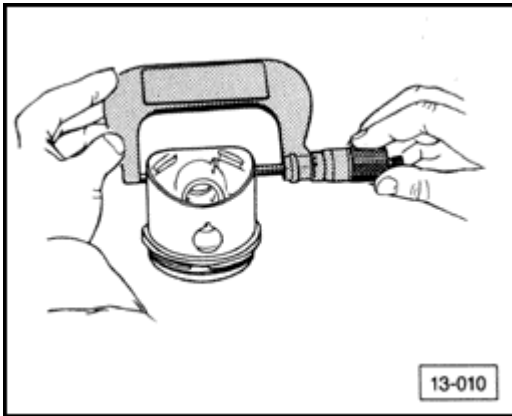

- measure approximately 6.0 mm (15/64 in.) from lower edge of skirt at 90° angle to piston pin axis

Nominal dimension tolerance:

- maximum 0.04 mm (0.0016 in.)

Cylinder bore, checking

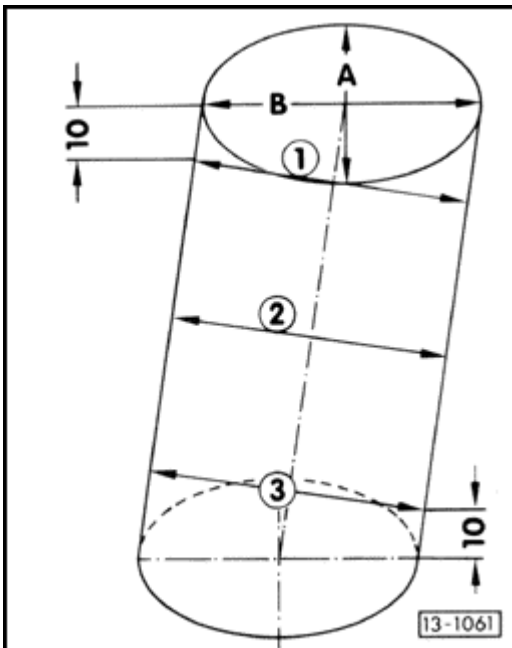

- measure at three points in cross direction **A** and longitudinal direction **B**

Use inside micrometer 50 - 100 mm (2 to 4 in.).

Maximum deviation from nominal dimension:

- 0.08 mm (0.003 in.)

CAUTION!

Do not measure cylinder bore when cylinder block is mounted to work bench with engine mount 3269 . Engine mounted in fixture can cause distortion affecting measurement.

Volkswagen Corrado 1990 - 1994
General Engine
Engine - Crankshaft, Crankcase (Page 13-38)

Piston and cylinder dimensions (in mm)

Size	Piston	Cylinder bore
Standard	80.985	81.01
1st oversize	81.485	81.51
2nd oversize	81.985	82.01