

Telephone:
 Fax:
 VAT Registration No.:

A16	ABS control module
A163	AC compressor control module
A63	AC control module
B161	AC refrigerant pressure sensor
S292	AC/heater function control panel
B138	Accelerator pedal position (APP) sensor
A137	Airbag control module
G1	Alternator
31	Battery -
30	Battery +
S13	Brake pedal position (BPP) switch
B132	Camshaft position (CMP) sensor
H100	Catalytic converter system warning lamp
S258	Clutch pedal position (CPP) switch
R57	Crankcase breather heater
B54	Crankshaft position (CKP) sensor
S79	Cruise control master switch
S80	Cruise control selector switch
X1	Data link connector (DLC)
A130	Diagnostic module
EP	Earth point
A35	Engine control module (ECM)
A95	Engine coolant blower motor control module
B24	Engine coolant temperature (ECT) sensor
Y104	Evaporative emission (EVAP) canister purge valve
Y151	Exhaust gas recirculation (EGR) valve actuator
B149	Exhaust gas recirculation (EGR) valve position sensor
M12	Fuel pump (FP)
K20	Fuel pump (FP) relay
F	Fuse
X28-I	Fuse box/relay plate, fascia 1
B72-I	Heated oxygen sensor (HO2S) 1
B72-II	Heated oxygen sensor (HO2S) 2
A52	Ignition amplifier
T1	Ignition coil
15	Ignition switch - ignition ON

Manufacturer: Volkswagen

Model: Golf/Golf Estate (98-06) 1,6 16V

© Autodata Limited 2010

Engine code: BCB

Output: 77 (105) 5700

Valid forever. 2021.08.26

Tuned for: R-Cat

Year: 2002-06

V8.500-ENGH482530

/Autodata

50	Ignition switch - start signal
A162	Immobilizer control module
Y3	Injector
A5	Instrument panel
A75	Instrumentation control module
B25	Intake air temperature (IAT) sensor
B69	Knock sensor (KS)
B83	Manifold absolute pressure (MAP) sensor
W3	Spare cable
P7	Tachometer
H101	Throttle control system warning lamp
A177	Throttle control unit
M89	Throttle motor
B169	Throttle motor position sensor
A57	Transmission control module (TCM)
B33	Vehicle speed sensor (VSS)
P9	Vehicle speedometer

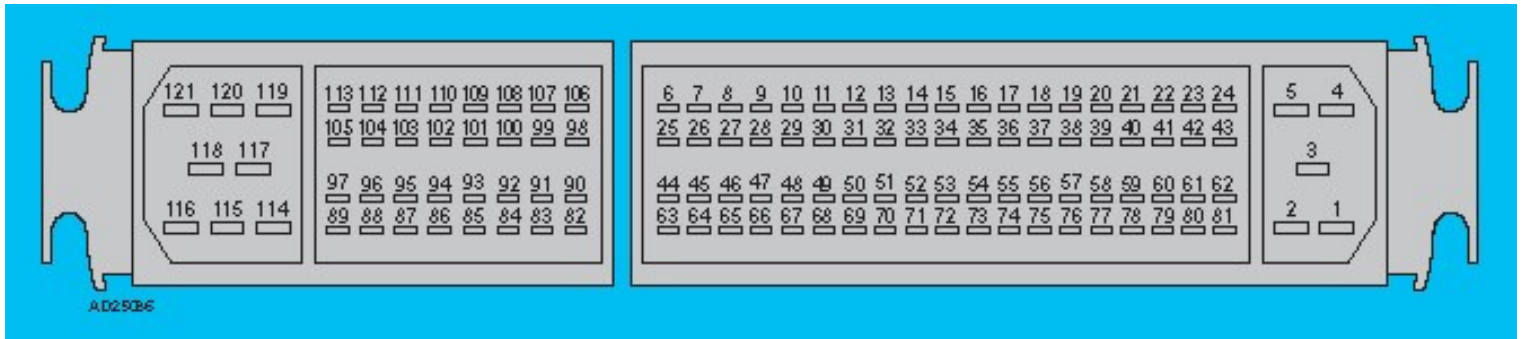

bl = blue	br = brown	el = cream	ge = yellow
gn = green	gr = grey	nf = neutral	og = orange
rs = pink	rt = red	sw = black	vi = violet
ws = white	hbl = light blue	hgn = light green	rbr = maroon
x = braided cable	y = high tension	z = non-cable connection	

NOTE: In certain diagrams (Citroen, Peugeot & Renault), colour codes are replaced by numbers which are used to identify a particular cable and not the colour. In this instance, the cables will be numbered at each end close to the harness connector.

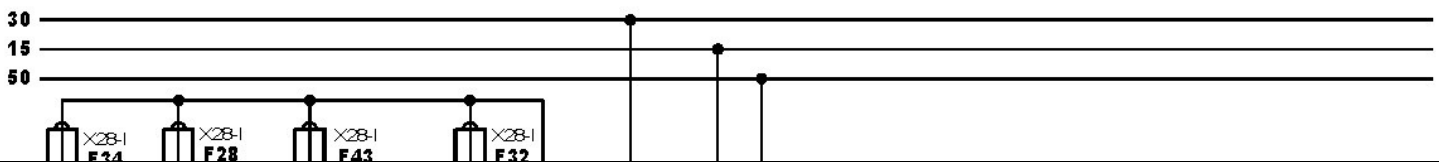

Manufacturer: Volkswagen

Engine code: BCB

Tuned for: R-Cat

Model: Golf/Golf Estate (98-06) 1,6 16V

Output: 77 (105) 5700

Year: 2002-06

© Autodata Limited 2010

Valid forever. 2021.08.26

V8.500-ENGH482530

/Autodata

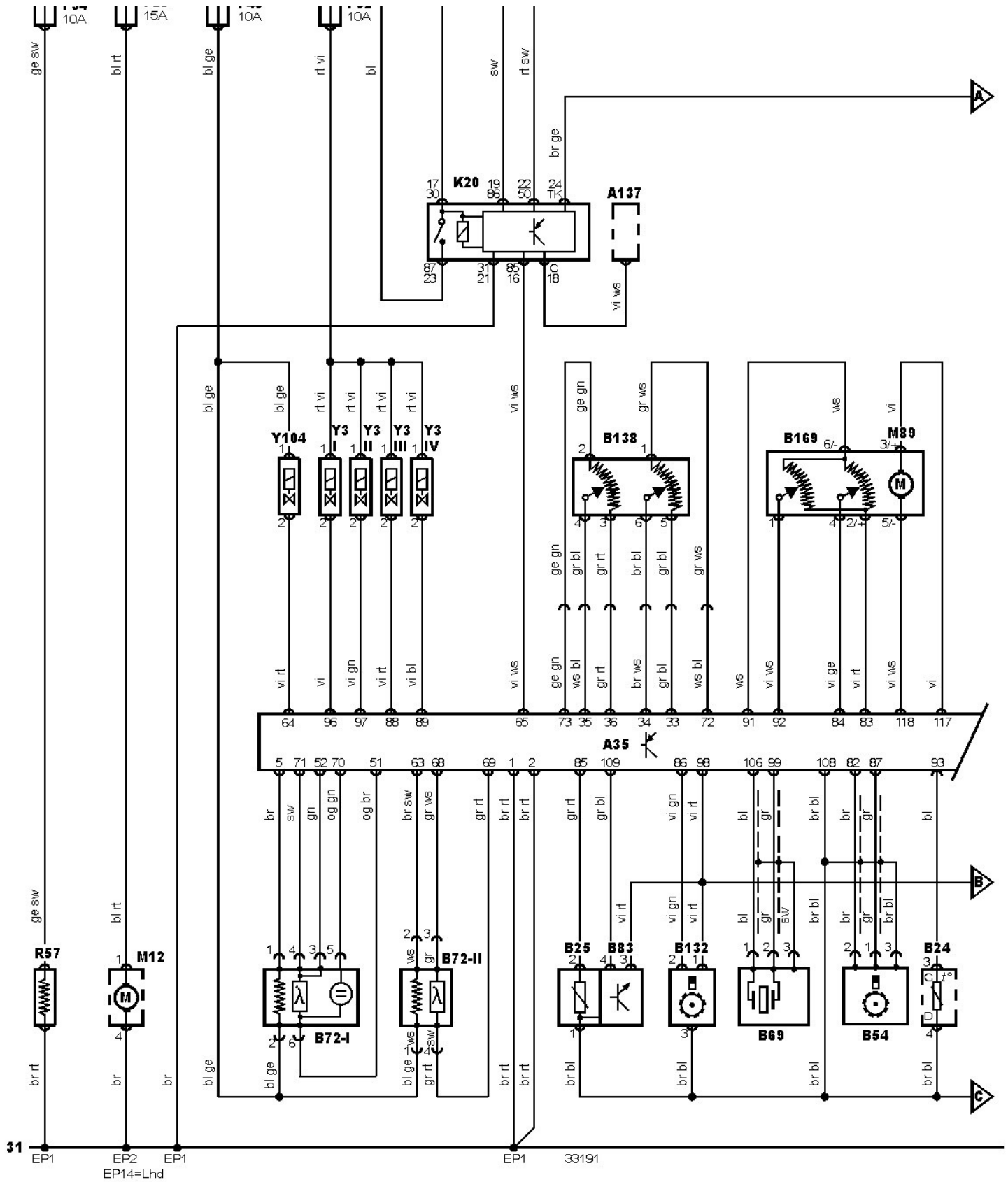

Manufacturer: Volkswagen
 Engine code: BCB
 Tuned for: R-Cat

Model: Golf/Golf Estate (98-06) 1,6 16V
 Output: 77 (105) 5700
 Year: 2002-06

© Autodata Limited 2010
 Valid forever. 2021.08.26
 V8.500-ENGH482530 **Autodata**

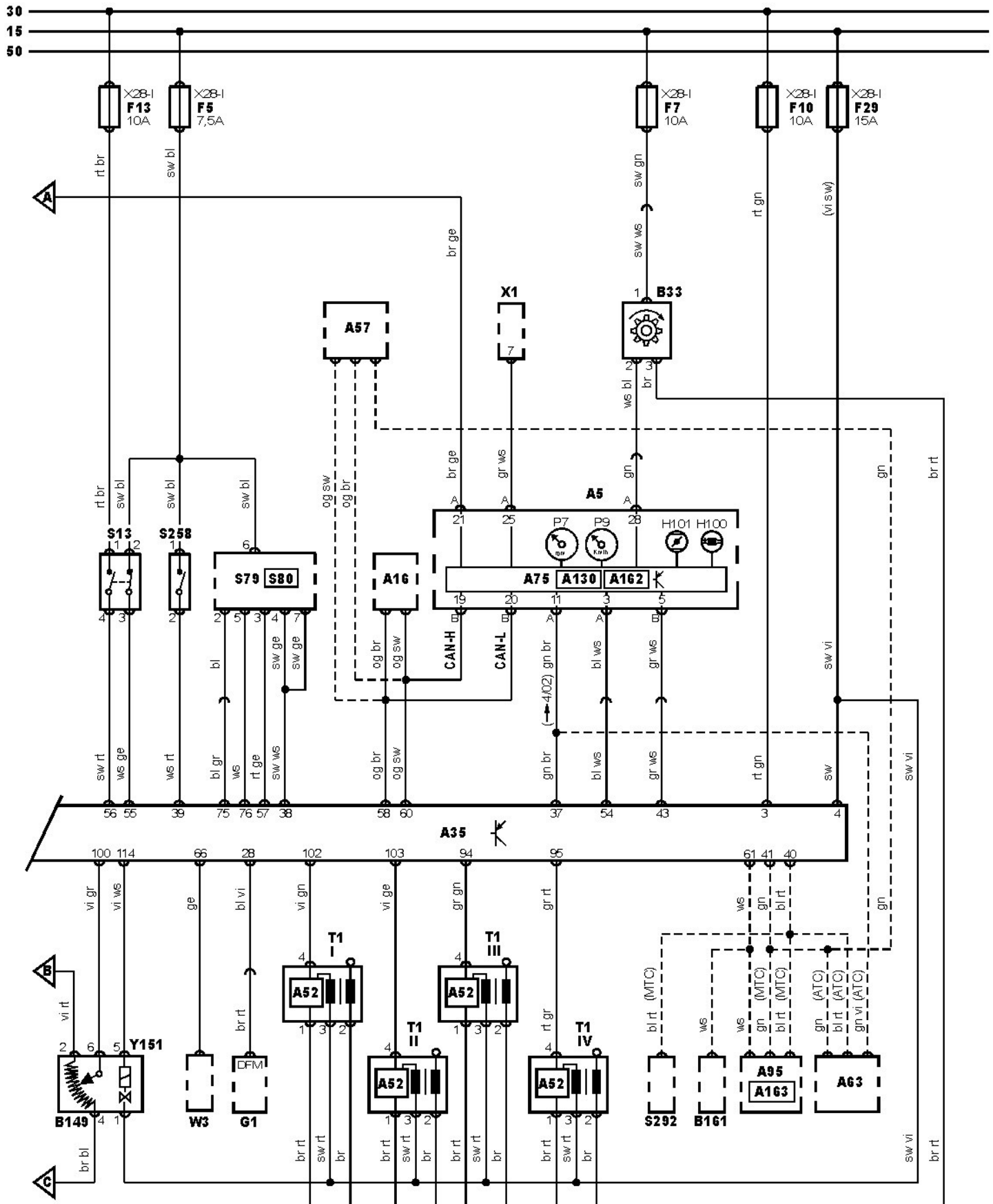

Manufacturer: Volkswagen
Engine code: BCB
Tuned for: R-Cat

Model: Golf/Golf Estate (98-06) 1,6 16V
Output: 77 (105) 5700
Year: 2002-06

© Autodata Limited 2010
 Valid forever. 2021.08.26
 V8.500-ENGH482530 **Autodata**

33192

EP1

EP4

EP1

EP4

EP1

EP4

EP1

EP4

EP1

Manufacturer: Volkswagen	Model: Golf/Golf Estate (98-06) 1,6 16V	© Autodata Limited 2010
Engine code: BCB	Output: 77 (105) 5700	Valid forever. 2021.08.26
Tuned for: R-Cat	Year: 2002-06	V8.500-ENGH482530 <i>/Autodata</i>