

WIRING DIAGRAMS

Article Text

1991 Volkswagen Passat

For Volkswagen Technical Site

Copyright © 1998 Mitchell Repair Information Company, LLC

Wednesday, August 25, 1999 09:09PM

ARTICLE BEGINNING

1990-91 WIRING DIAGRAMS

Volkswagen

Passat

COMPONENT LOCATION MENU

COMPONENT LOCATIONS TABLE

AA

| Component | Figure No. (Location) |
|---|-----------------------|
| A/C RELAY | 6 (C 20) |
| A/C SYSTEM | 6 (B-E 21-23) |
| A/T CONTROL UNIT | 2 (B-D 4) |
| ABS DIAG CONN | 7 (D 24) |
| ABS HYDRAULIC PUMP FUSE | 7 (E 27) |
| ABS HYDRAULIC PUMP RELAY | 7 (D-E 27) |
| ABS HYDRAULIC UNIT | 7 (E 25-26) |
| ABS MAIN RELAY | 7 (D-E 24) |
| ABS VALVES FUSE | 7 (E 24) |
| ALTERNATOR | 1 (A-B 3) |
| ANTI-LOCK BRAKE CONTROL UNIT | 7 (B 25-26) |
| ANTI-THEFT CONTROL UNIT | 6 (A-B 20) |
| BATTERY | 1 (A 2) |
| CIG LIGHTER | 4 (A 12) |
| COLD START VALVE | 2 (B 5) |
| COOLANT TEMP SENSOR | 3 (D 10) |
| CRUISE CONTROL SWITCH | 1 (C 3) |
| CRUISE CONTROL UNIT | 1 (D 3) |
| DOOR SWITCHES | 7 (A-B 27) |
| EMERGENCY FLASHER RELAY | 4 (C 13) |
| EMERGENCY FLASHER SWITCH | 4 (E 12-13) |
| FRESH AIR BLOWER SWITCH (W A/C) | 6 (E 20) |
| FRESH AIR BLOWER SWITCH (W/O A/C) | 3 (E 8-9) |
| FUEL PUMP | 3 (D 8) |
| FUEL PUMP RELAY | 3 (C 8) |
| FUEL TANK UNIT | 3 (E 8) |
| FUSE #23 | 6 (C 20) |
| FUSE #51 | 1 (C 2) |
| FUSE/RELAY PANEL LAYOUT | 8 (D-E 29-31) |
| GLOVE BOX LIGHT | 4 (A 12-13) |
| HEADLIGHT SWITCH | 5 (A 16-17) |
| HEATED O2 SENSOR | 2 (A-B 5) |
| HORN RELAY | 5 (C 16) |
| IGNITION BOOSTER | 2 (D-E 7) |
| IGNITION SWITCH | 3 (A 8-9) |
| INSTRUMENT CLUSTER | 8 (A-E 28-29) |
| LEFT DOOR LATCH SWITCH | 4 (A 13) |
| LEFT FRONT DOOR LOCK SWITCH | 9 (C-D 34) |

WIRING DIAGRAMS

Article Text (p. 2)

1991 Volkswagen Passat

For Volkswagen Technical Site

Copyright © 1998 Mitchell Repair Information Company, LLC

Wednesday, August 25, 1999 09:09PM

| | |
|--|--------------|
| LEFT FRONT WINDOW SWITCH | 9 (A 34) |
| LOAD REDUCTION RELAY | 3 (B- C 9) |
| LOW COOLANT LEVEL SWITCH | 3 (D 11) |
| MAP READING LIGHT | 7 (A 25) |
| MCU DIAG CONN | 2 (C 7) |
| MIRROR HEATERS | 5 (B 19) |
| MDTRONIC CONTROL UNIT (MCU) | 2 (A- C 7) |
| MULTI-FUNCTION SWITCH | 2 (A- B 4) |
| OIL PRESSURE SWITCH | 3 (D 10) |
| PARK BRAKE SWITCH | 4 (A 14) |
| POWER DOOR LOCK CONTROL UNIT | 9 (E 32) |
| POWER MIRROR SWITCH | 5 (A 19) |
| POWER WINDOW CB | 9 (B 32-33) |
| POWER WINDOW CONTROL UNIT | 9 (A- B 32) |
| RAD COOLING FAN AFTER RUN CTRL UNIT | 1 (E 3) |
| RAD COOLING FAN THERMO SWITCH (W/O A/C) | 1 (D- E 3) |
| REAR WINDOW DEFOG SWITCH | 5 (A 17) |
| REAR WIPER MOTOR | 5 (E 19) |
| REAR WIPER/WASHER RELAY | 5 (C- D 18) |
| SEAT BELT SWITCH | 4 (A 13) |
| SEAT BELT WARNING CTRL UNIT | 4 (B- C 13) |
| STARTER | 1 (A 3) |
| STARTER INTERLOCK /BACK-UP LIGHT RLY | 1 (B- C 3) |
| STOP LT SW | 4 (D 15) |
| TRUNK LIGHT | 6 (A 22) |
| VACUUM VENT VALVE | 1 (D 2) |
| VANITY MIRRORS | 7 (A 24) |
| WARNING INDICATORS | 4 (A 13) |
| WASHER NOZZLE HEATERS | 5 (A 18) |
| WIPER INTERMITTENT SWITCH | 5 (E 17- 18) |
| WIPER MOTOR | 5 (E 16) |
| WIPER/WASHER INTERMITTENT RELAY | 5 (C 17- 18) |
| AA | |

WIRING DIAGRAMS

WIRING DIAGRAMS

Article Text (p. 3)

1991 Volkswagen Passat

For Volkswagen Technical Site
Copyright © 1998 Mitchell Repair Information Company, LLC
Wednesday, August 25, 1999 09:09PM

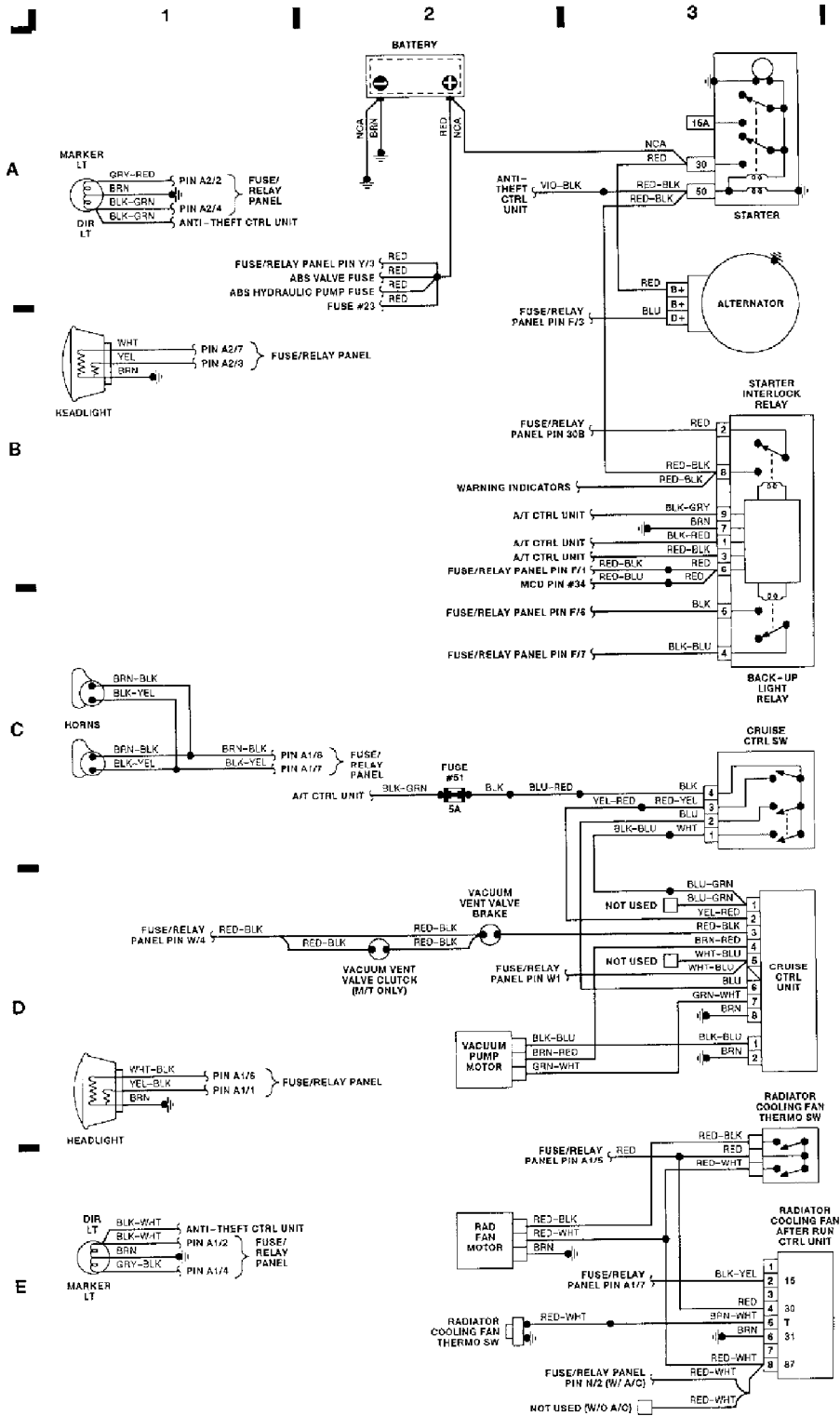

Fig. 1: Engine Compartment & Headlights (Grid 1-3)

WIRING DIAGRAMS
Article Text (p. 4)
 1991 Volkswagen Passat
 For Volkswagen Technical Site
 Copyright © 1998 Mitchell Repair Information Company, LLC
 Wednesday, August 25, 1999 09:09PM

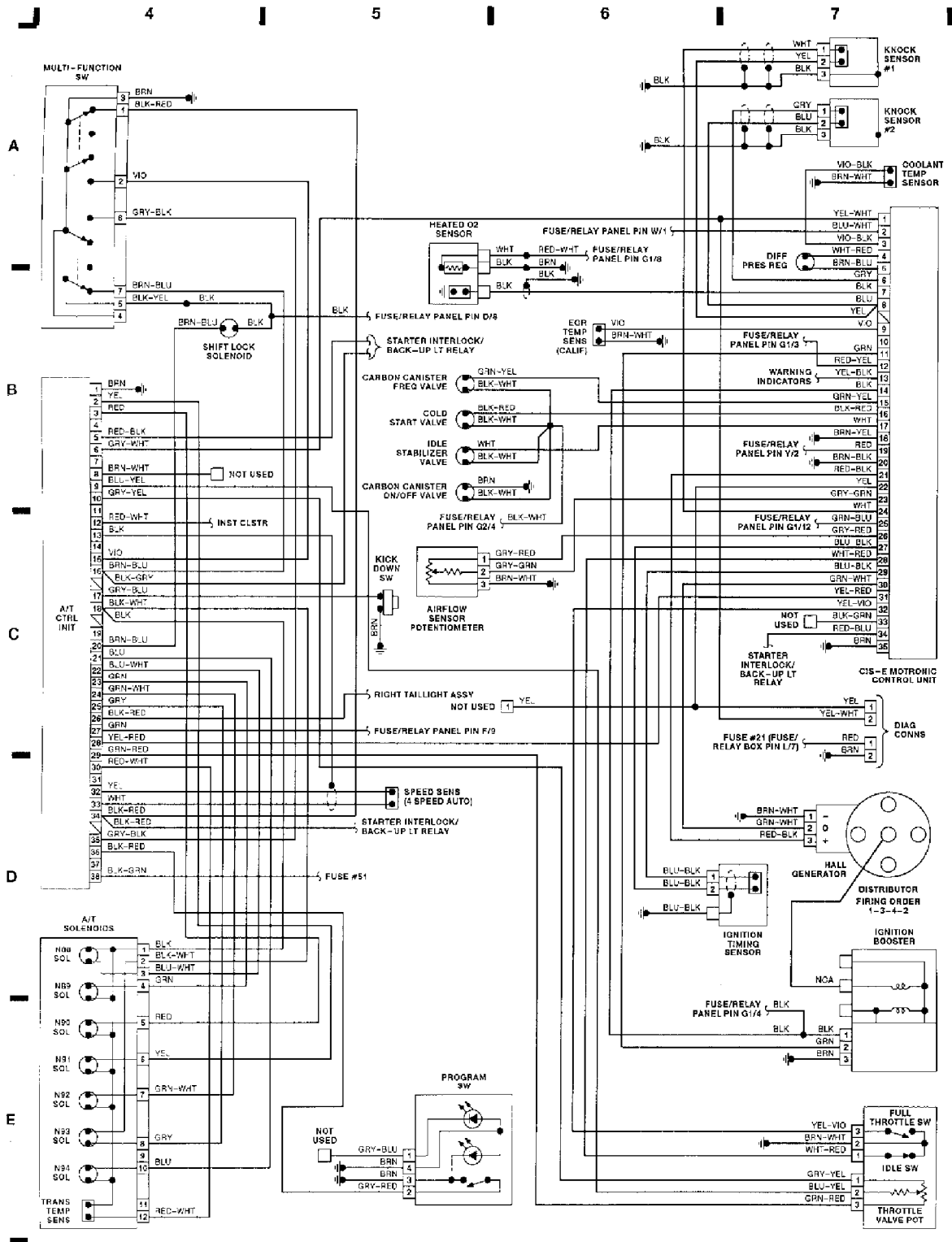

Fig. 2: Computer Engine Control, A/T Ctrl Unit (Grid 4-7)

WIRING DIAGRAMS

Article Text (p. 5)

1991 Volkswagen Passat

For Volkswagen Technical Site

Copyright © 1998 Mitchell Repair Information Company, LLC

Wednesday, August 25, 1999 09:09PM

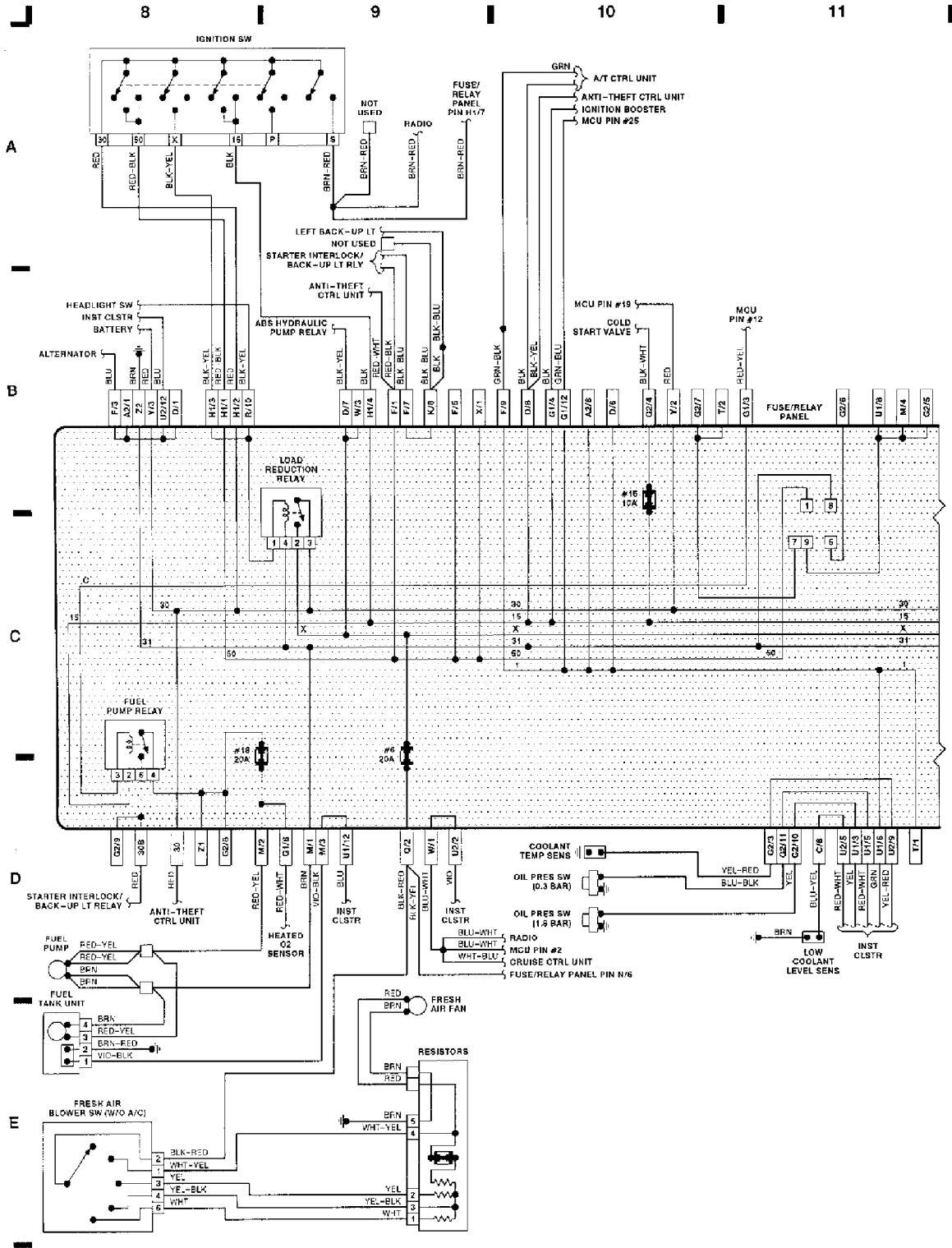

Fig. 3: Fuse Block (1 of 4), Ignition Sw (Grid 8-11)

WIRING DIAGRAMS
Article Text (p. 6)
 1991 Volkswagen Passat
 For Volkswagen Technical Site
 Copyright © 1998 Mitchell Repair Information Company, LLC
 Wednesday, August 25, 1999 09:09PM

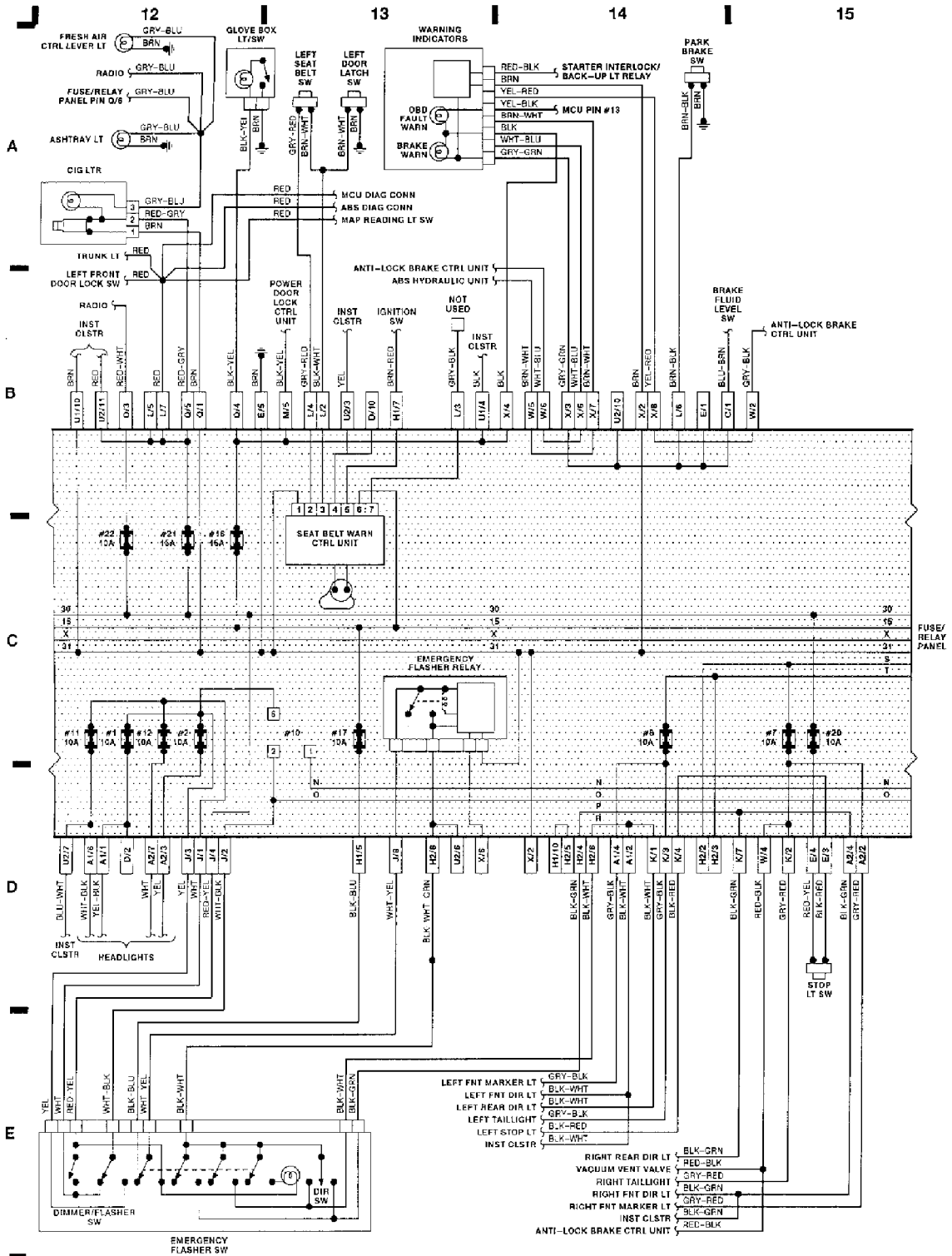

Fig. 4: Fuse Block (2 of 4), Emergency Flasher Sw (Grid 12-15)

WIRING DIAGRAMS

Article Text (p. 7)

1991 Volkswagen Passat

For Volkswagen Technical Site
Copyright © 1998 Mitchell Repair Information Company, LLC
Wednesday, August 25, 1999 09:09PM

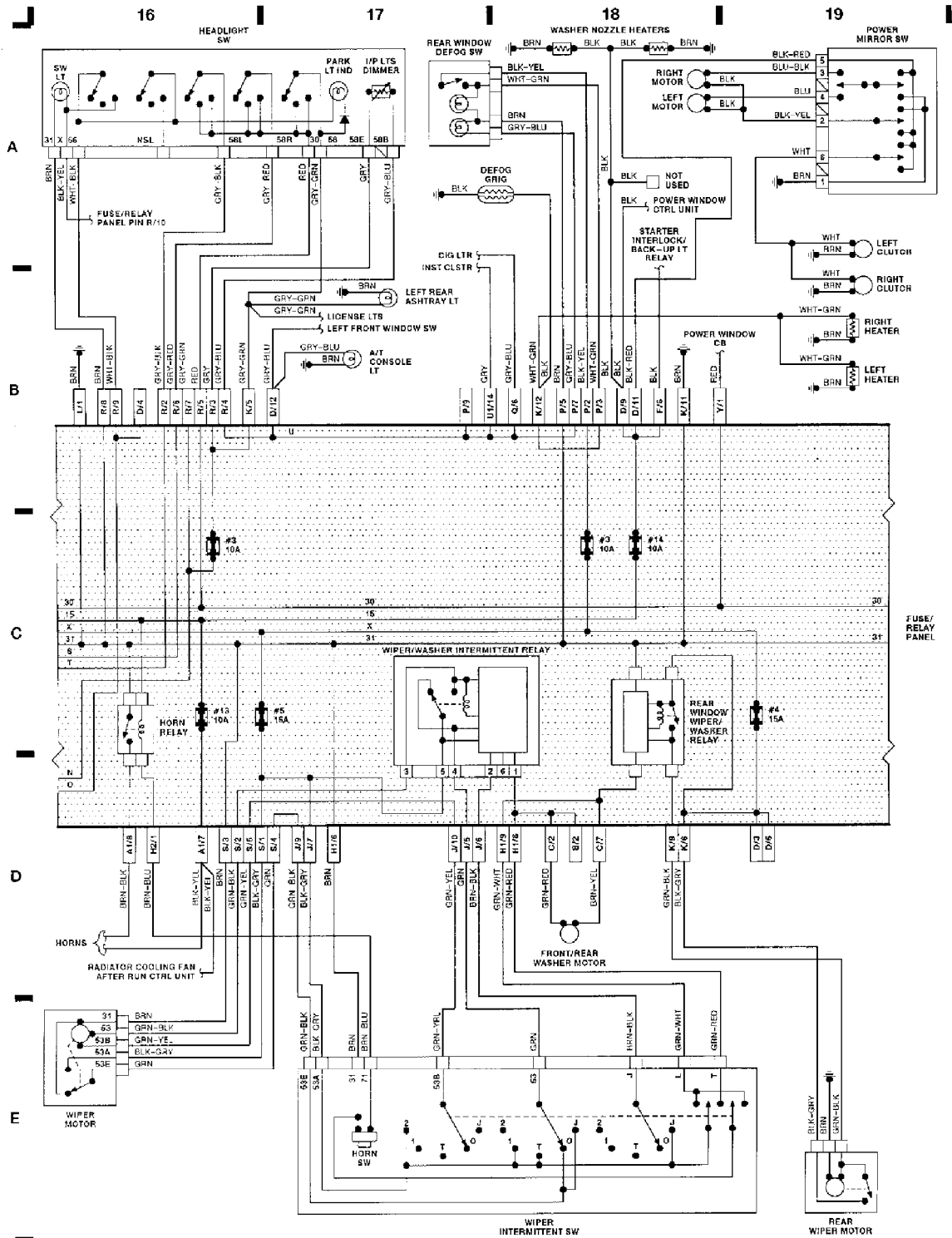

Fig. 5: Fuse Block (3 of 4), Pwr Mir, Washer/Wiper (Grid 16-19)

WIRING DIAGRAMS

Article Text (p. 8)

1991 Volkswagen Passat

For Volkswagen Technical Site
Copyright © 1998 Mitchell Repair Information Company, LLC
Wednesday, August 25, 1999 09:09PM

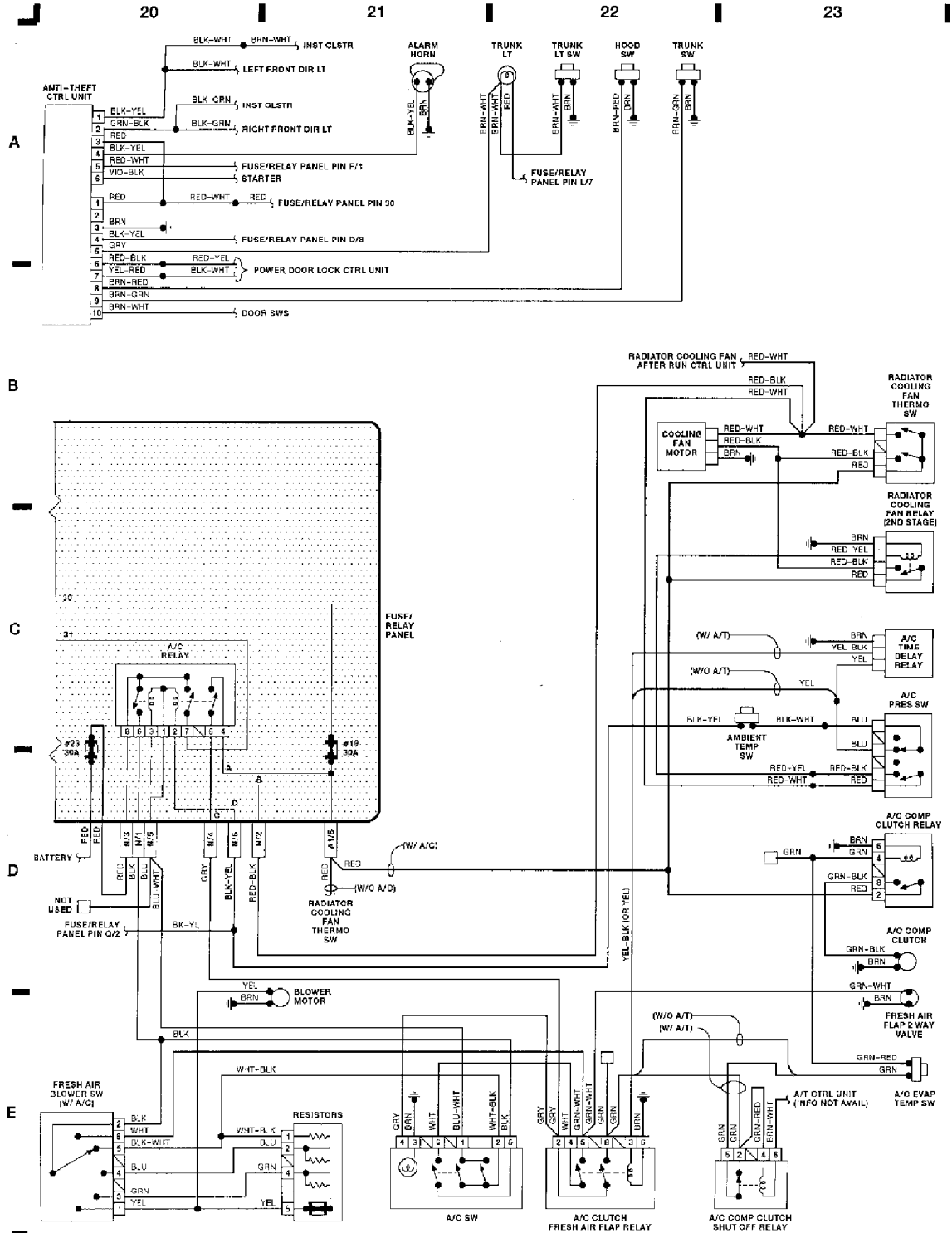

Fig. 6: Fuse Block (4 of 4), Anti-Theft, A/C Sys (Grid 20-23)

WIRING DIAGRAMS
Article Text (p. 9)
 1991 Volkswagen Passat
 For Volkswagen Technical Site
 Copyright © 1998 Mitchell Repair Information Company, LLC
 Wednesday, August 25, 1999 09:09PM

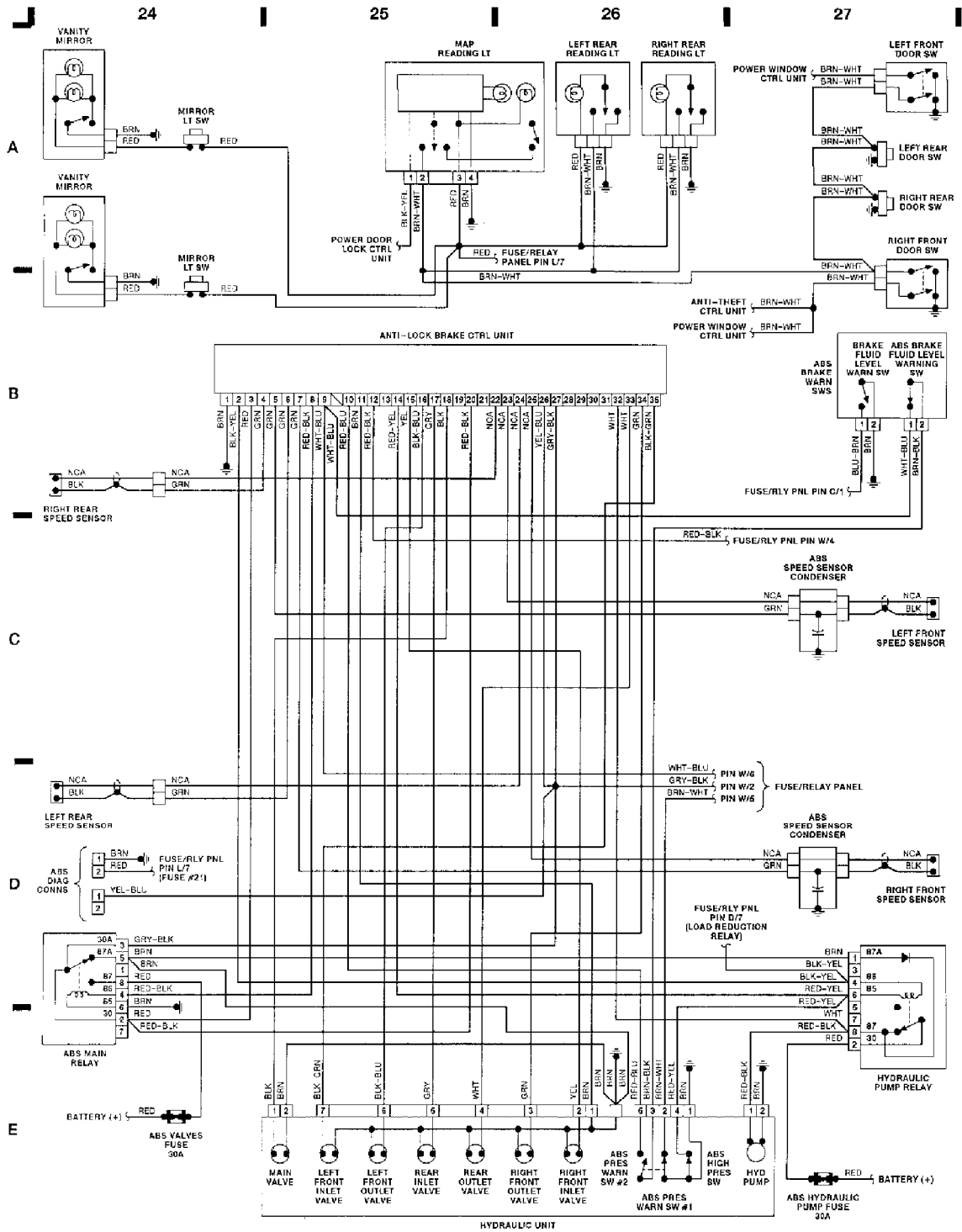

Fig. 7: Anti-Lock Brakes, Inter Lts, Hydraulic Unit (Grid 24-27)

WIRING DIAGRAMS

Article Text (p. 10)

1991 Volkswagen Passat
For Volkswagen Technical Site
Copyright © 1998 Mitchell Repair Information Company, LLC
Wednesday, August 25, 1999 09:09PM

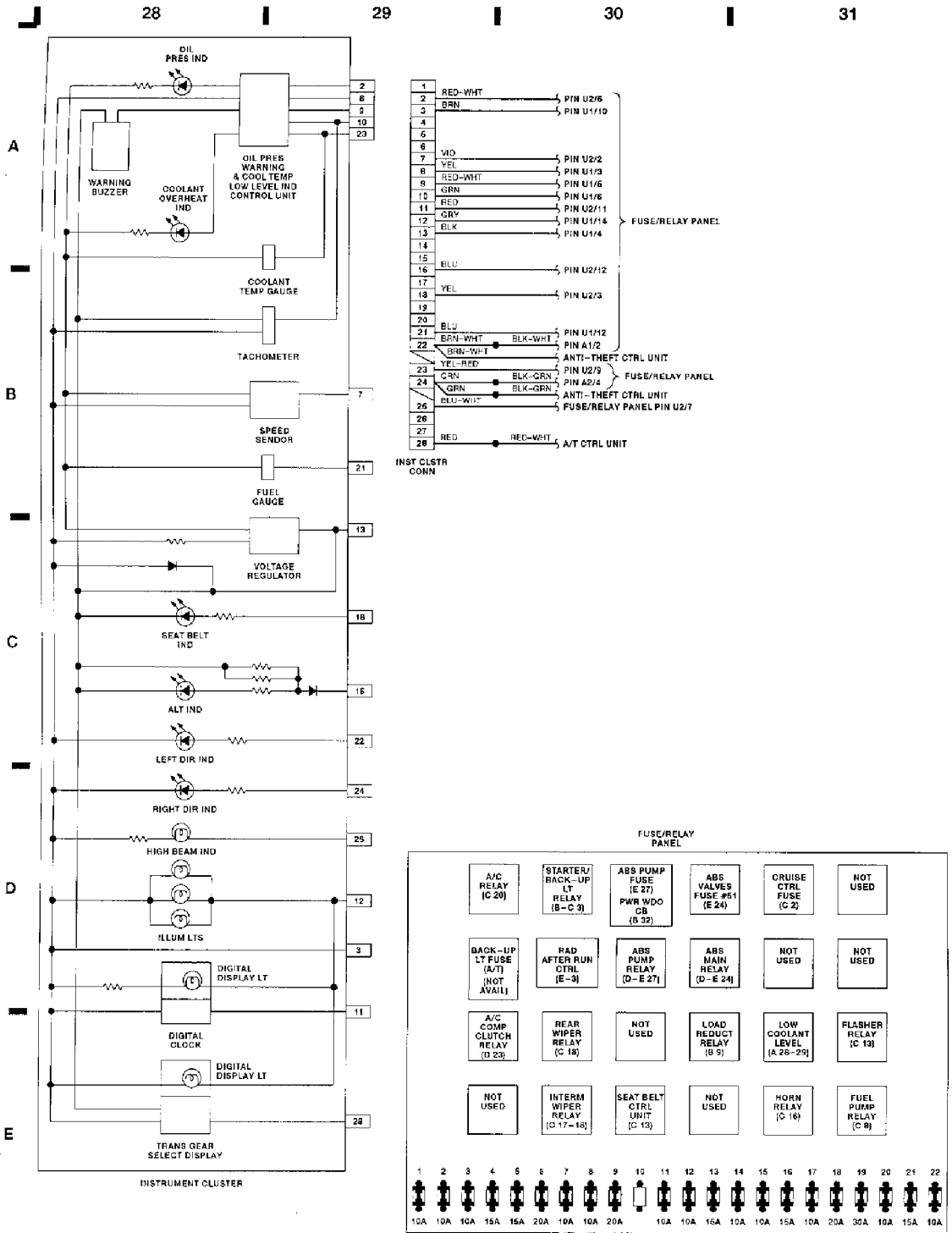

Fig. 8: Instrument Cluster, Fuse/Relay Panel (Grid 28-31)

WIRING DIAGRAMS
Article Text (p. 11)
 1991 Volkswagen Passat
 For Volkswagen Technical Site
 Copyright © 1998 Mitchell Repair Information Company, LLC
 Wednesday, August 25, 1999 09:09PM

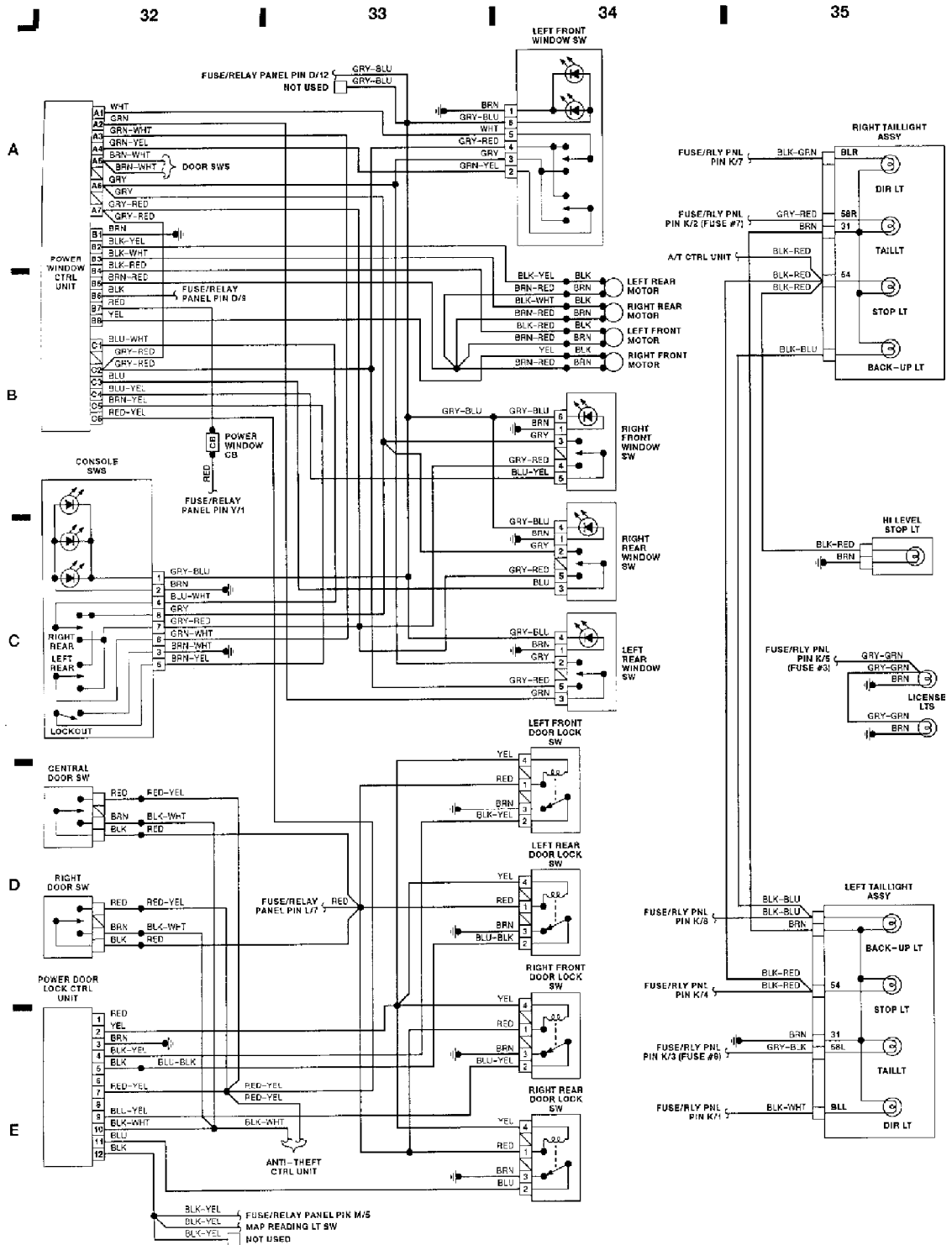

Fig. 9: Pwr Window/Doors, Console Sw, Taillights (Grid 32-35)

END OF ARTICLE