

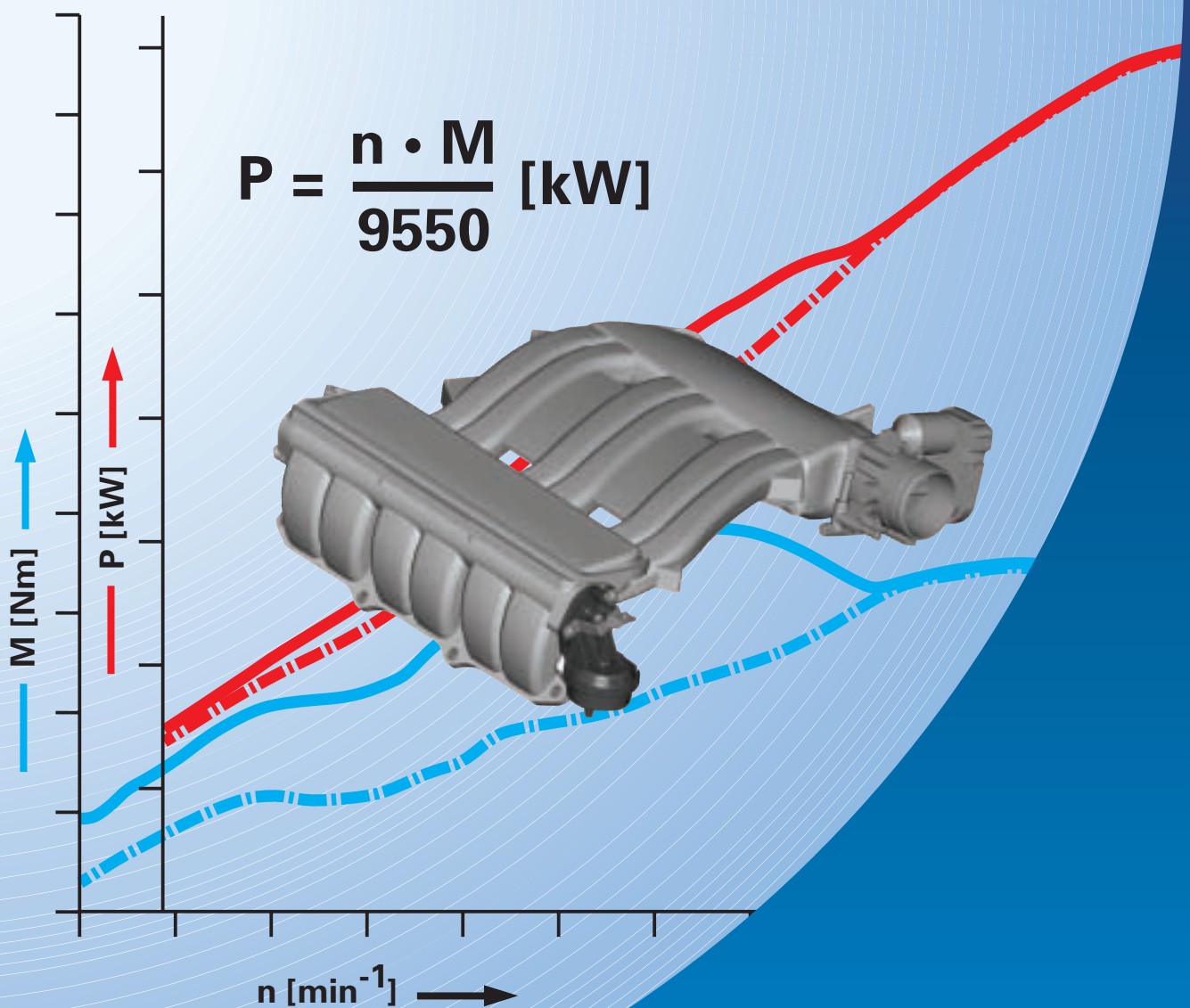

Self-study programme 212

Variable Intake Manifold in VR Engines

Principles and Description of Operation





212_020

The output and torque of an engine have the greatest effect on the engine's character.

These, in turn, are greatly affected by the degree to which the cylinder is filled and the geometric form of the intake tract.

High torque requires an intake manifold with a geometry different to one for high power output.

A medium intake manifold length with a medium diameter represents a compromise, but a variable intake manifold is optimal.

This self-study programme explains how it was possible to optimise the torque and output of the VR engine with the concept and design of the new intake manifold and just how an intake tract affects the air supply.

The VR6 engine, in which the conventional intake manifold has been replaced by the new variable intake manifold, provides an example which makes the increase in power and torque very clear.

A patent for the variable intake manifold concept of the VR engine has been applied for.

NEW



Important Note



The self-study programme is not a workshop manual!

Please always refer to the relevant Service literature for all inspection, adjustment and repair instructions.

Table of contents



Power and torque	4
Air supply	5
Air channelling in engine	5
The principle of resonance charging	5
The variable intake manifold of the VR engines	8
Torque position of VR6 variable intake manifold	9
Power position of VR6 variable intake manifold	10
Power and output of VR6 engine	11
Load-dependent change-over concept	12
Power collector and change-over barrel	13
Filling the power collector	14
Intake manifold change-over	15
Intake manifold change-over valve N156	16
Service	17
Test your knowledge	19

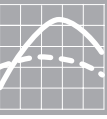

Power and torque



High power and high torque with low fuel consumption are characteristics of a modern car engine.

How was this goal achieved?

The power P is the product of engine speed n and torque M .

Greater power can be attained through either greater torque or higher engine speed.

The numerous moving masses in an engine (pistons, connecting rods, crankshaft and so on) limit engine speed.

Thus only torque remains to increase power.

To increase engine torque, one can increase the displacement or the compression.

Because vehicle taxes are often assessed according to displacement in spite of technical advantages, the goal must be attained with a given displacement in other ways, namely by increasing the efficiency of the engine.

A flatter torque curve as a function of engine speed thus becomes the ultimate measure.

One achieves maximum torque through complete combustion of the fuel-air mixture at the right moment.

But every complete combustion requires a certain ratio between air and fuel. The engine should be provided optimally with air at every speed.

The volumetric efficiency (VE, represented as λ_L in the graphics), makes a qualitative statement about the air supply:

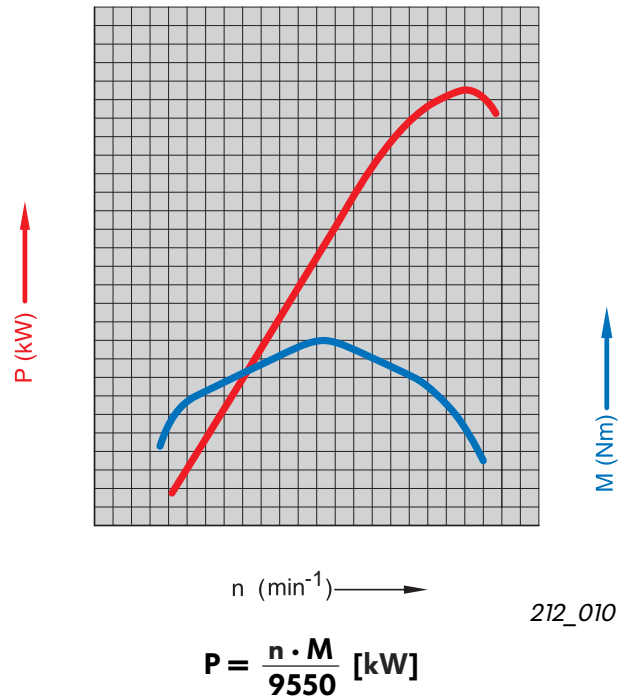

n = engine speed [rpm] (min^{-1} in graphics)

M = torque [Nm]

9550 = constant derived from the calculation of all factors when the numerical values for n are entered in rpm and M , in Nm.

$$\lambda_L = \frac{m_L}{m_{th}}$$

m_a = actual air mass in cylinder in [kg]

m_{th} = theoretical air mass in [kg]

Air channelling on engine

The intake system is responsible for feeding the engine with the air necessary for combustion.

It ensures an even supply of air to all cylinders.

Engines with carburetors or throttle-body injection also mix fuel with the air in the intake tract, and a fuel-air mixture is transported.

Intake tracts of multi-point injection systems transport only air.

This opens substantially more possibilities for the designer to design the intake manifold in order to achieve better exploitation of the self-charging effect of gas momentum.

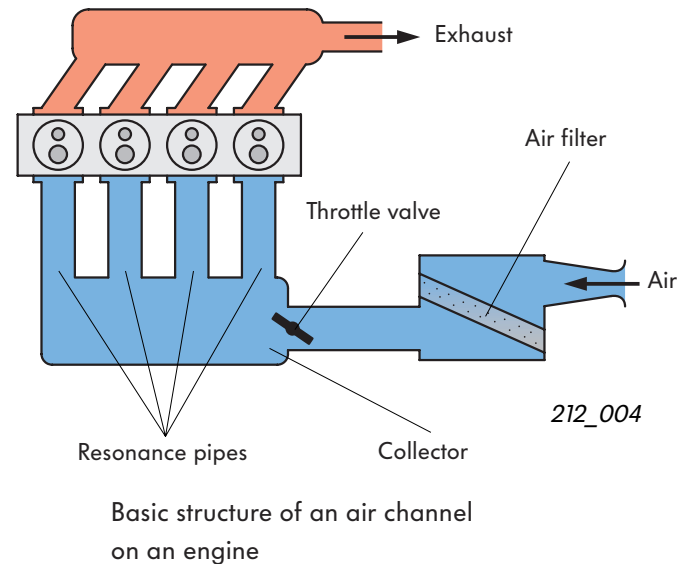

The principle of resonance charging

An intake system works according to the principle of resonance charging, that is, high and low-pressure waves are used to charge the cylinder, in order to achieve greater volumetric efficiency.

Consider the events in the intake tract.

The inlet valve opens.

The piston moves downwards in the cylinder, in the direction of bottom dead centre (BDC).

It creates a low-pressure wave in the vicinity of the inlet valve.

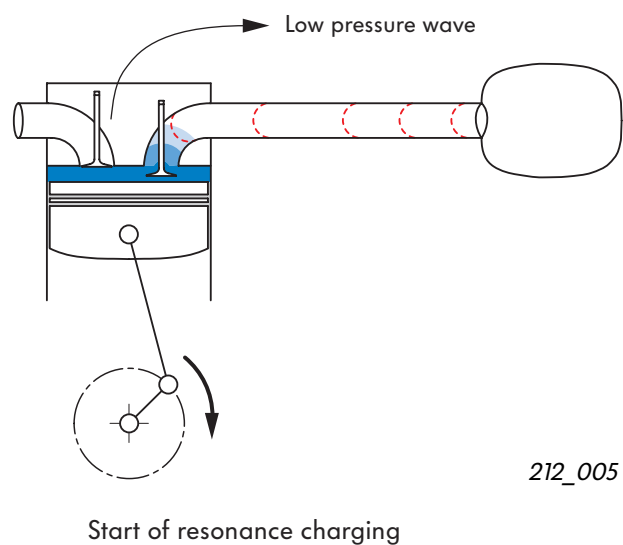

The air supply

This low-pressure wave propagates itself through the resonance pipe to the other end, which protrudes into a collector.

The low-pressure wave at the end of the pipe acts on the volume of air present in the collector.

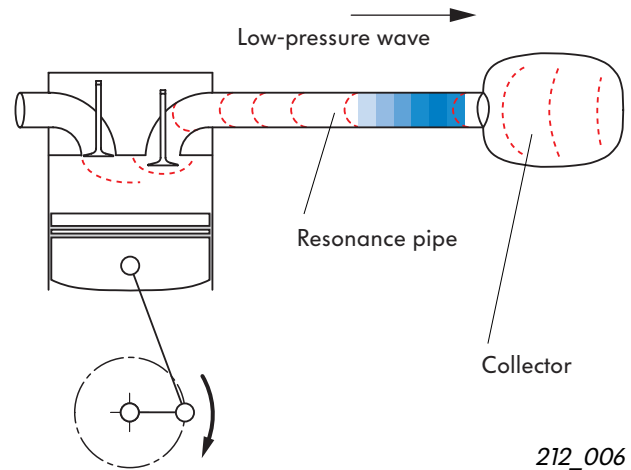

Propagation of low-pressure wave

212_006

The pressure of the volume of air in the collector is approximately equal to ambient air pressure. This is significantly higher than the air pressure at the open end of the resonance pipe.

The low pressure now present at the end of the pipe pulls along the air mass present here.

They force themselves simultaneously into the resonance pipe so that where the low-pressure wave was, an equally large high-pressure wave develops, which propagates itself towards the inlet valve.

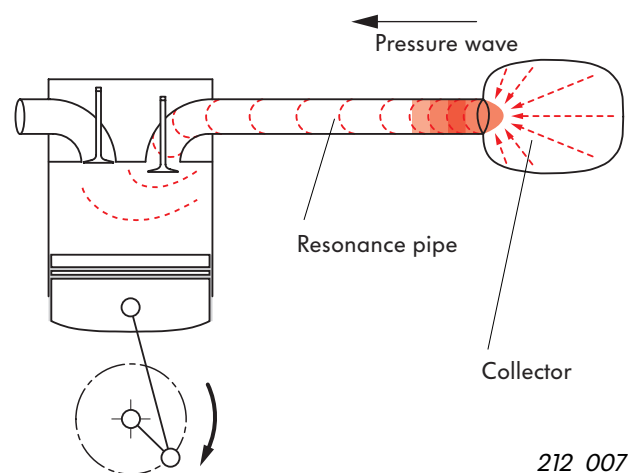

Development of high-pressure wave

212_007

This effect is also characterised in this way:

The low-pressure wave is reflected at the open end of the pipe in the collector.

This high-pressure wave travels back through the resonance pipe and pushes the air mass past the still-open inlet valve into the cylinder. This continues until the pressure before the inlet valve and the pressure in the cylinder are equal.

The engine experiences “ram-effect” charging. The volumetric efficiency (see page 4) reaches values of about 1.0 and even above. As a result, when the inlet valve closes, backflow of the ram-effect charging into the intake pipe is prevented.

The time t (in milliseconds) required by the low and high-pressure waves to cover the distance S from the inlet valve to the collector and back is always the same because they move at the speed of sound, v .

But the time period during which the inlet valve is opened is dependent on engine speed.

As engine speed increases, the period of time during which the inlet valve is open and air can flow into the cylinder decreases.

A high-pressure wave returning through a resonance pipe designed for low engine speeds will run into an inlet valve which has already closed. “Ram-effect” charging cannot take place.

It is clear that resonance pipes of different lengths are required for optimal charging at every engine speed.

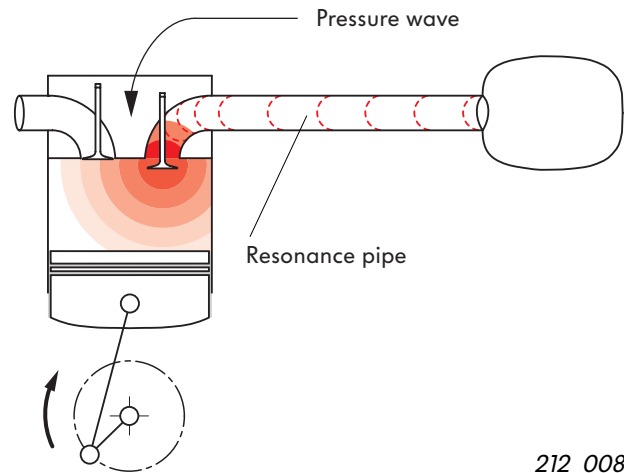

“Ram-effect” charging

212_008

$$t = \frac{s = \text{constant (length of resonance pipe)}}{v = \text{constant (speed of sound)}} \quad [\text{ms}]$$

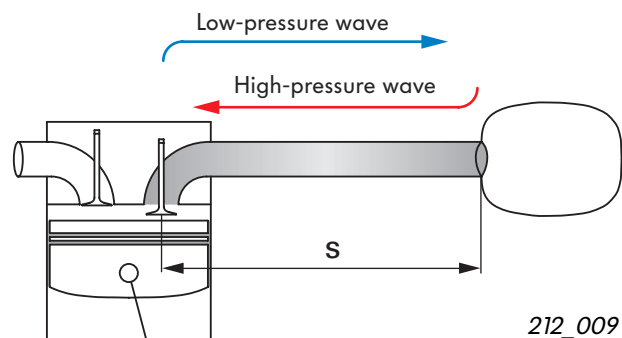

212_009



The higher the engine speed, the shorter the resonance pipe length.

The technical compromise is resonance pipes of different lengths!

Long pipes (torque stage) for low to middle engine speeds.

Short pipes (power stage) for high engine speeds.

Resonance pipes of different lengths can be opened or closed depending on engine speed = **variable intake manifold**.

The variable intake manifold of the VR engines

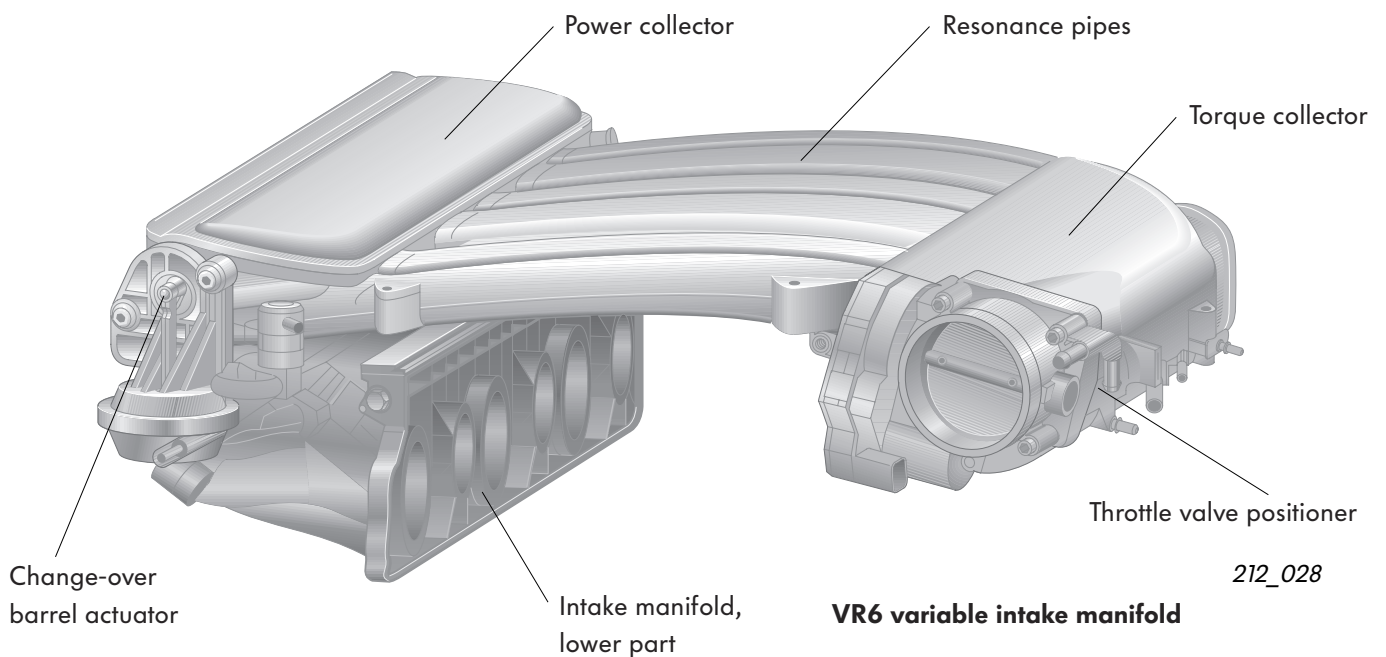

The variable intake manifold is designed as an over-head intake manifold with differing channel lengths. In addition, the resonance pipe lengths are specific to the cylinder bank and therefore averages.

The lengths differ for the VR5 and VR6 engines.

Resonance pipe lengths (mm)	VR5	VR6
Torque pipes	700	770
Power pipes	330	450

For assembly reasons, the variable intake manifold is divided into an upper and a lower part.

The injectors and fuel rail with pressure regulator are integrated into the lower intake manifold part.

The upper intake manifold part contains the resonance pipes, the power collector, the change-over barrel with actuator, the torque collector and the throttle valve positioner, which is attached to the torque collector.

The air channels of the intake ports in the cylinder head go through the lower intake manifold part to the resonance pipes in the upper intake manifold part. Here they branch into torque and power pipes.

The torque pipes follow a tight curve over the cylinder head and terminate in the torque collector.

The power pipes follow a wider curve above the torque pipes and terminate in the second collector, the power collector, which is located over the front part of the torque pipes.

A change-over barrel is inserted in the power pipes, perpendicular to them. It opens the power pipes and, consequently, the power collector as necessary.

A plastic variable intake manifold is planned for all VR engines.

This is more economical than cast aluminium, lighter and offers acoustic advantages.

Torque position of VR6 variable intake manifold

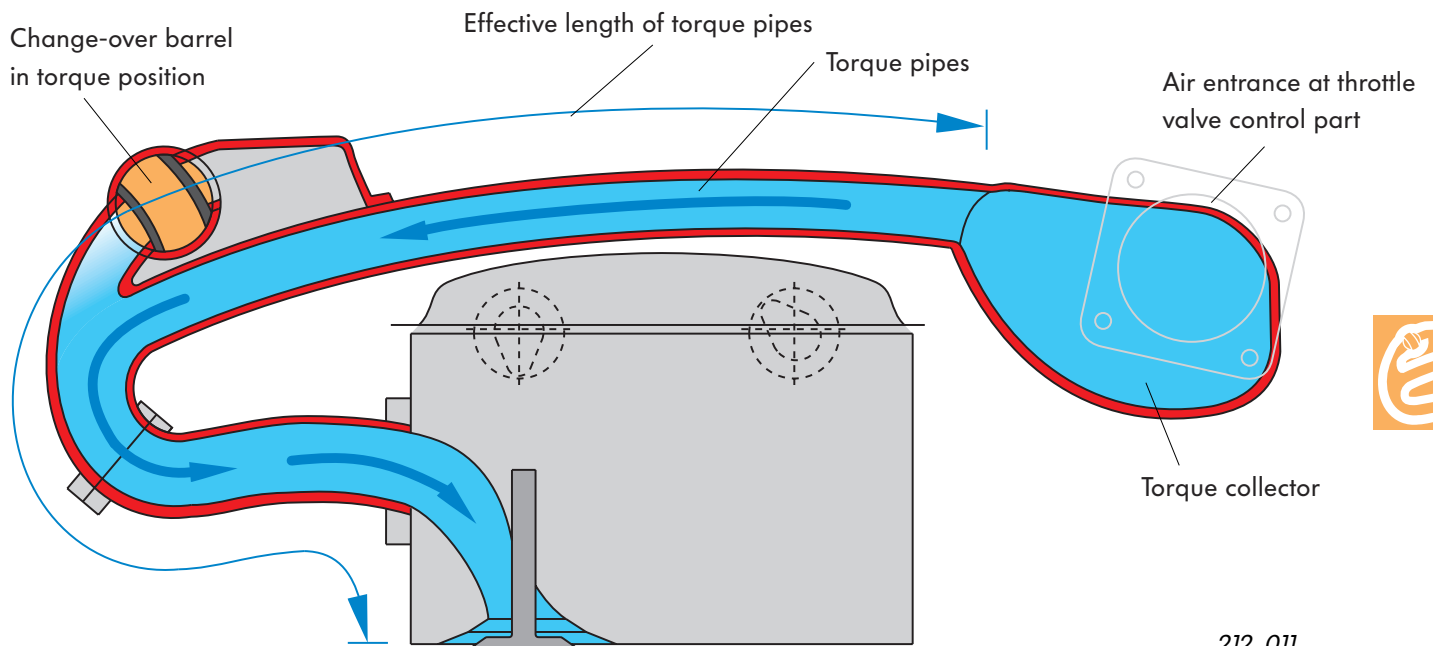

212_011

The torque position shows air channelling in low engine speed range.

The change-over barrel has closed the power pipes.

The cylinder draws air through the long torque pipes directly from the torque collector.

The effective length of the torque pipes (= resonance pipe length) is 770 mm.

The result at low and middle engine speeds is higher volumetric efficiency.

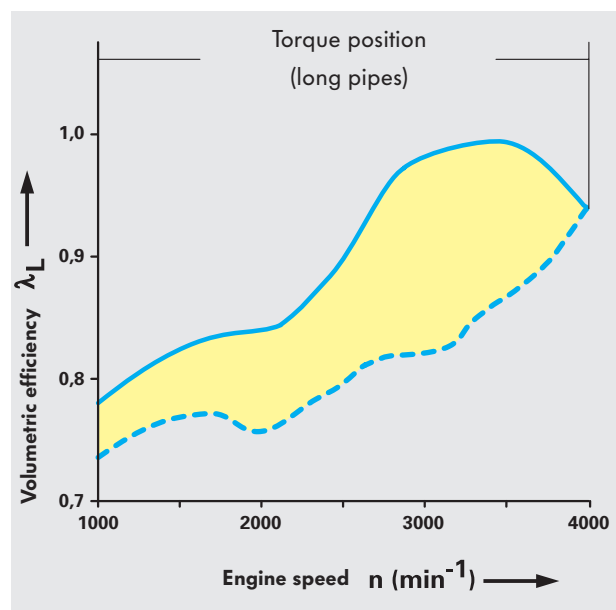

212_012

Comparison of volumetric efficiency

- with variable intake manifold
- - - without variable intake manifold
- improvement in volumetric efficiency

The variable intake manifold of the VR engines

Power position of the VR6 variable intake manifold

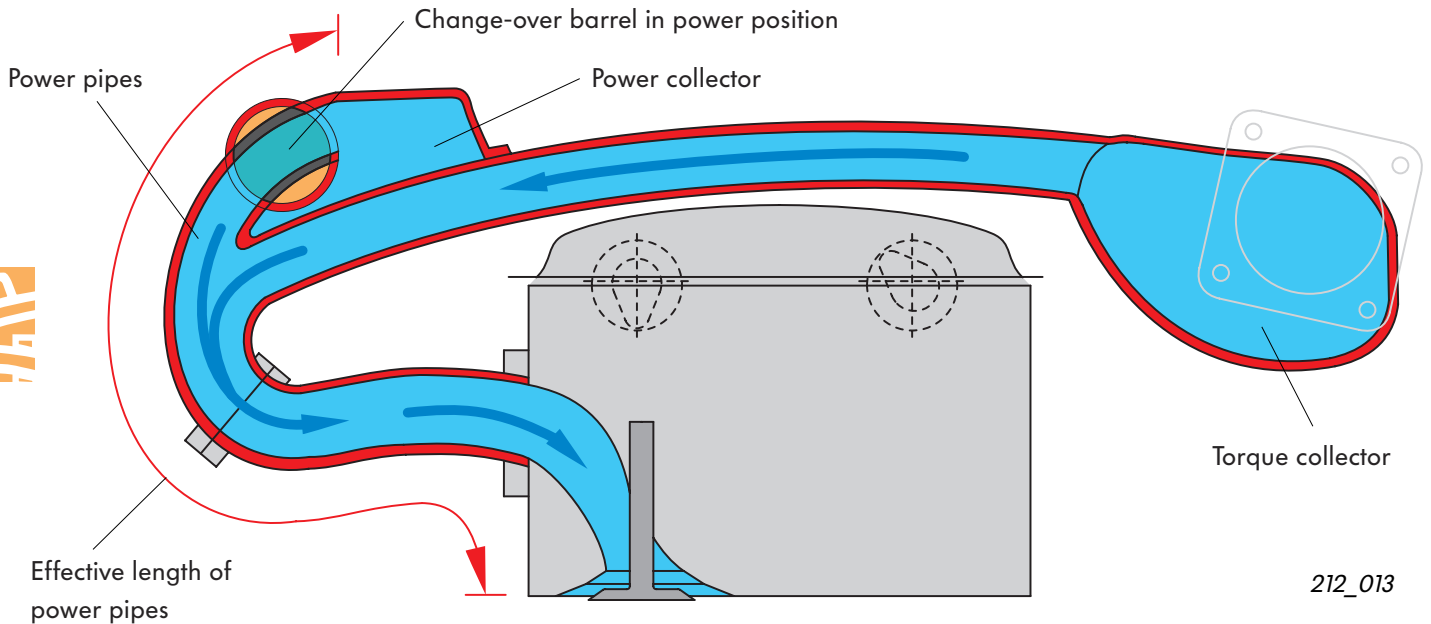

212_013

Change-over to power pipes at engine speed	VR5	VR6
rpm	4200	3950

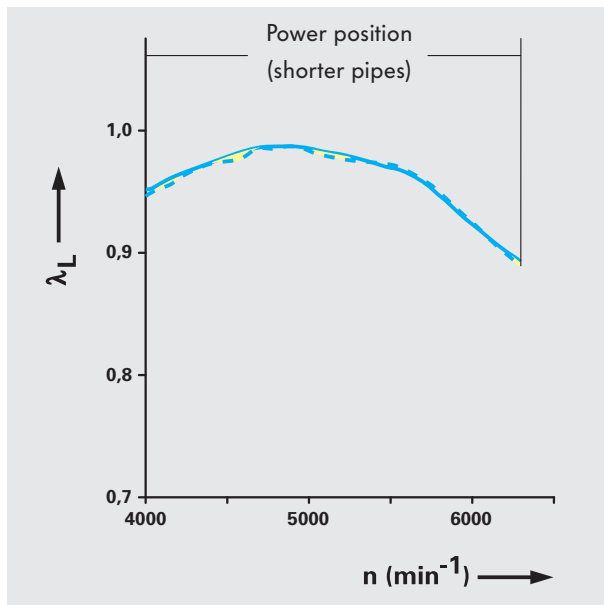

212_014

Comparison of volumetric efficiency

- With variable intake manifold
- - - Without variable intake manifold
- Improvement in volumetric efficiency

The change-over barrel is rotated 90° at a specified engine speed.

This action opens the power pipes and the connection to the power collector, which results in an effective length of 450 mm for the power pipes. Air is now supplied from both the torque pipes and the power pipes.

The power collector is supplied with air via the torque and power pipes leading to cylinders which are not drawing air (see also page 14).

The low-pressure wave created at the start of the intake process is reflected at the end of the power pipe in the power collector. Consequently, it returns after a short period to the inlet valve as a high-pressure wave.

The shortened length of the resonance pipe produces a high degree of volumetric efficiency at a high engine speed.

The power position, designed for the power range, results in slight differences, as expected.

Power and torque of VR6-Motor with and without variable intake manifold

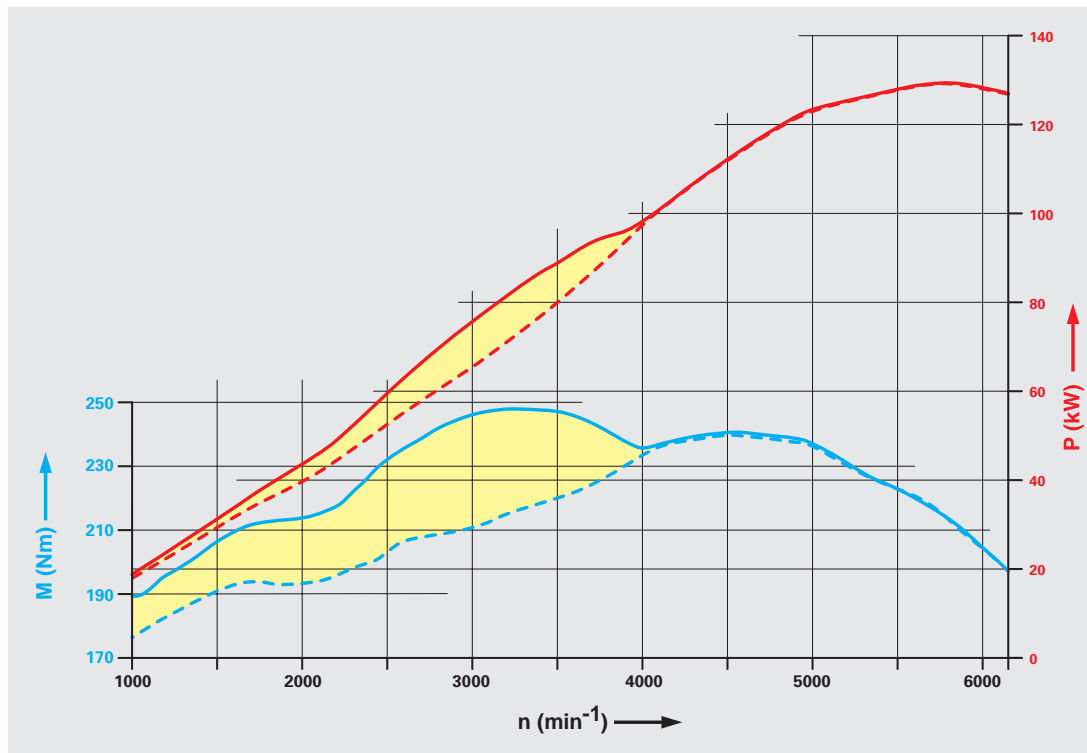

272_015

M = Torque
P = Power
n = Engine speed (rpm)

— Power with variable intake manifold
- - - Power without variable intake manifold
— Torque with variable intake manifold
- - - Torque without variable intake manifold
■ Gain in power and torque

The gains in power and torque in the low and middle engine speed ranges made with the new variable intake manifold on the VR6 engine are clearly recognisable (the VR5 engine had a variable intake manifold from the start of production).

The high torque permits a more relaxed driving style in the lower and middle engine speed ranges as well as the frequent use of higher gears without loss of pulling power but with low fuel consumption.

As a result, the change-over barrel is rarely operated.

Impurities such as dust or oil can lodge in the gap between the change-over barrel and its housing, impeding its operation.

To ensure its proper operation, the change-over concept was extended by an additional change-over point in the first stage of development.

The change-over barrel is held in the power position up to about 1,100 rpm and only then turned to the torque position.

This additional change-over point causes the change-over barrel to be operated repeatedly, and impurities cannot lodge on it.



The variable intake manifold of the VR engines

**A further development –
the load-dependent change-over
concept**



Patent has been applied for on this equipment!

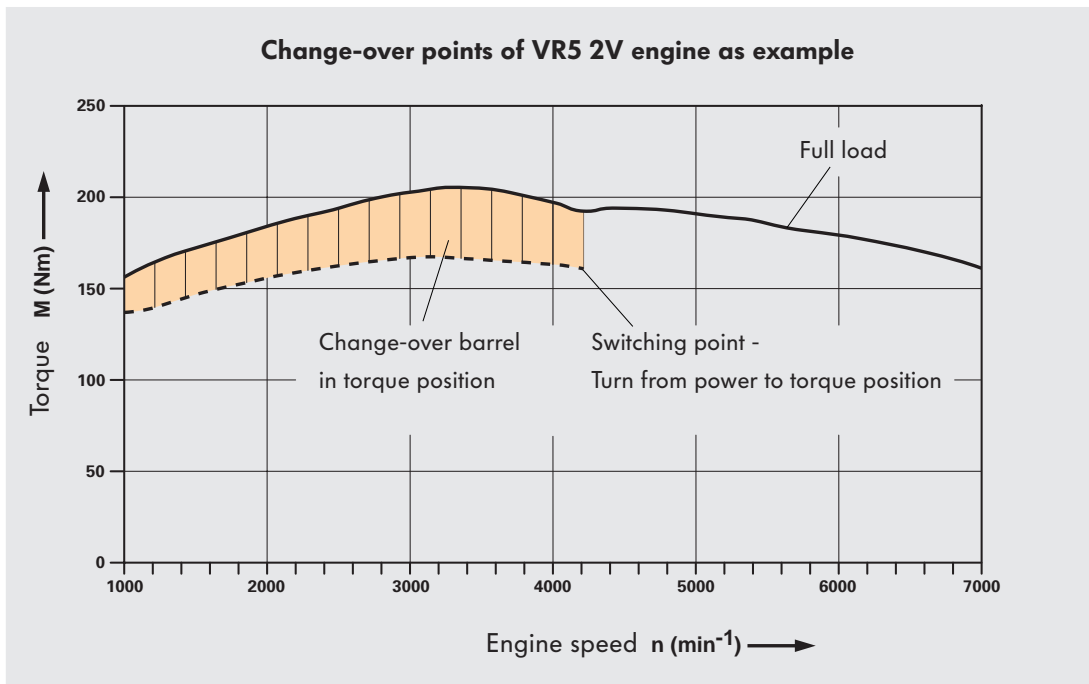

212_016

According to this concept, the change-over points for turning the change-over barrel are determined according to load.

Below full load, the change-over barrel is mapped to be in the power position. This is also the rest position when the engine is stopped.

To achieve maximum filling of the cylinder, it is not turned to the torque position until the engine is close to full load.

Because the resonance pipes are de-tuned, the resonance-charging effect in the partial load range is reduced.

For the same planned power, the engine can be operated with a lower load.

The gas dynamics in the intake manifold are reduced, consequently reducing the charging of the combustion chamber.

Advantages!
Lower fuel consumption
Smoother combustion
Improved acoustics

Power airbox and change-over barrel

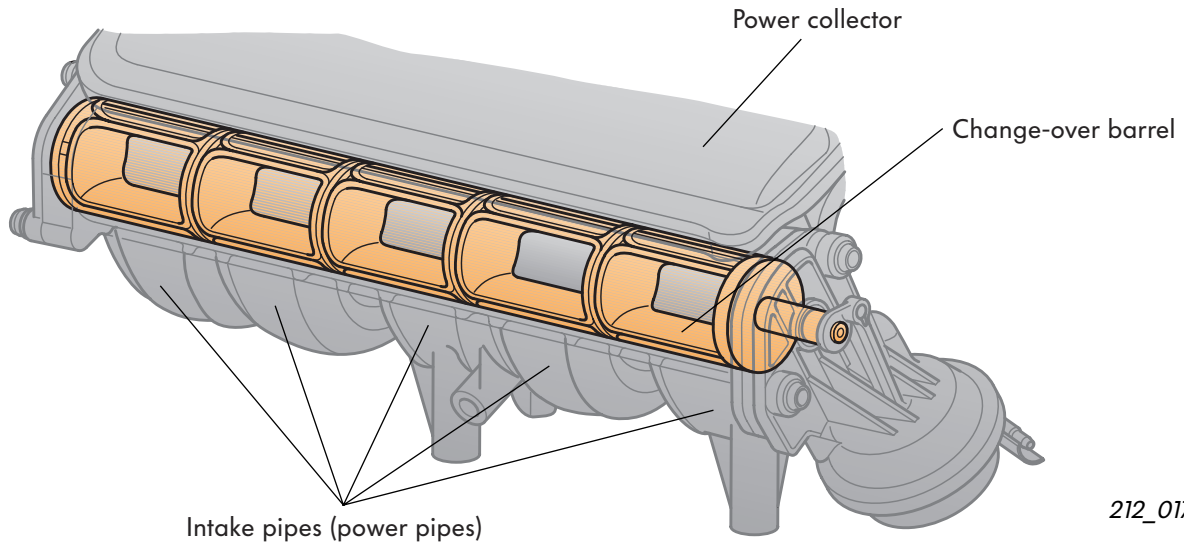

Variable intake manifold on VR5 engine with change-over barrel in torque position

The switch mechanism located in the upper intake manifold part works on the change-over barrel principle. The change-over barrel has a separate passage for each power pipe. In the power position, the passages become a part of the power pipe.

The change-over barrel is made of plastic and is elastically supported. Differing expansion coefficients of intake manifold and change-over barrel, and security against seizing place high demands on the reliability of the process. A radial tolerance between the change-over barrel to the power collector is necessary to ensure its operation but must not be too great.

Even minimal air gaps lead to a significant reduction in achieved torque. This reduction is caused by the reflected waves travelling between individual pipes to the power collector, resulting in the loss of energy.

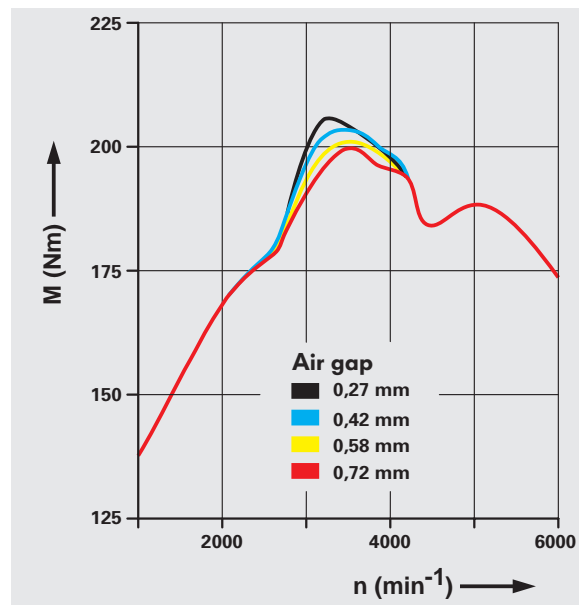

212_018

The influence of the air gap of the change-over collector on torque in the VR5 engine. Maximum torque shifts to a higher rpm range. In the power range (open power pipes), the air gap cannot have any significance.

The variable intake manifold of the VR engines

Filling the power collector

A reminder:

Closed change-over barrel = torque position

Each cylinder receives its charge of air directly from the torque collector through its respective torque pipe.

The power collector is closed for all cylinders. It has no influence on the volumetric efficiency of the cylinder.

The power collector is not filled either.

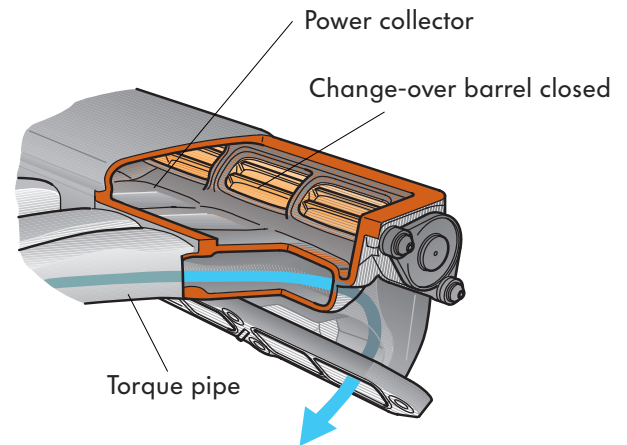

212_003

Open change-over barrel = power position

With its passages (one per pipe) open, the change-over barrel connects the power pipe to the power collector.

The cylinder which is drawing at the moment receives its air primarily from the power pipe but also through its torque pipe.

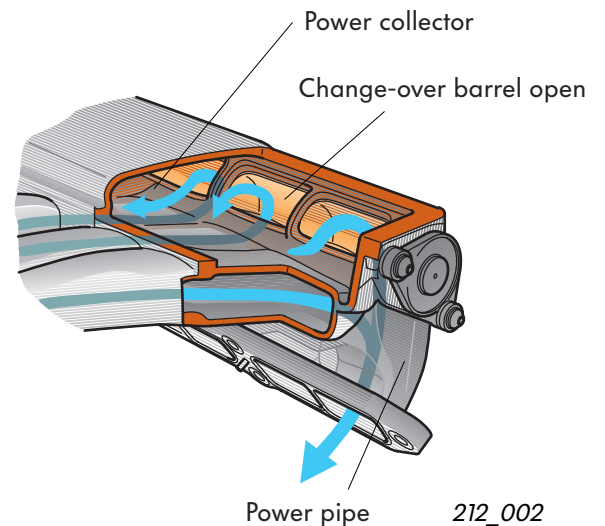

212_002

In the power position, the power collector is filled by the flowing volume of air which is reflected from the closed inlet valves of the cylinders which are not drawing air.

Air currents develop high velocities in the collectors.

Due to the over-all manifold design, a direct connection between torque and power collectors is not necessary for filling the power collector.

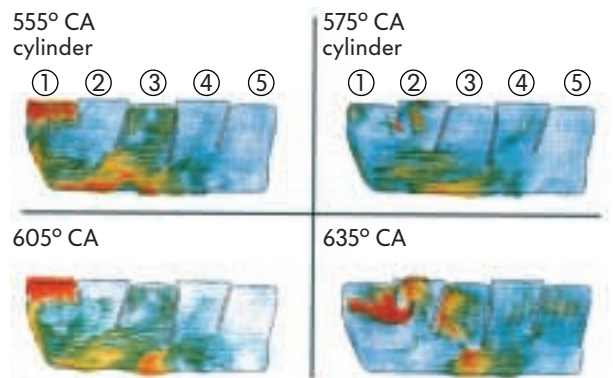

212_021

Example of current progression in collector.

At a crankshaft angle of 555°, the current moves from No. 3 cylinder 3 to No. 1 cylinder.

Beginning at about crankshaft angle 605°, the intake phase of No. 2 cylinder leads to a reversal of the current direction. Decimal points represented by commas in graphic.

Intake manifold change-over

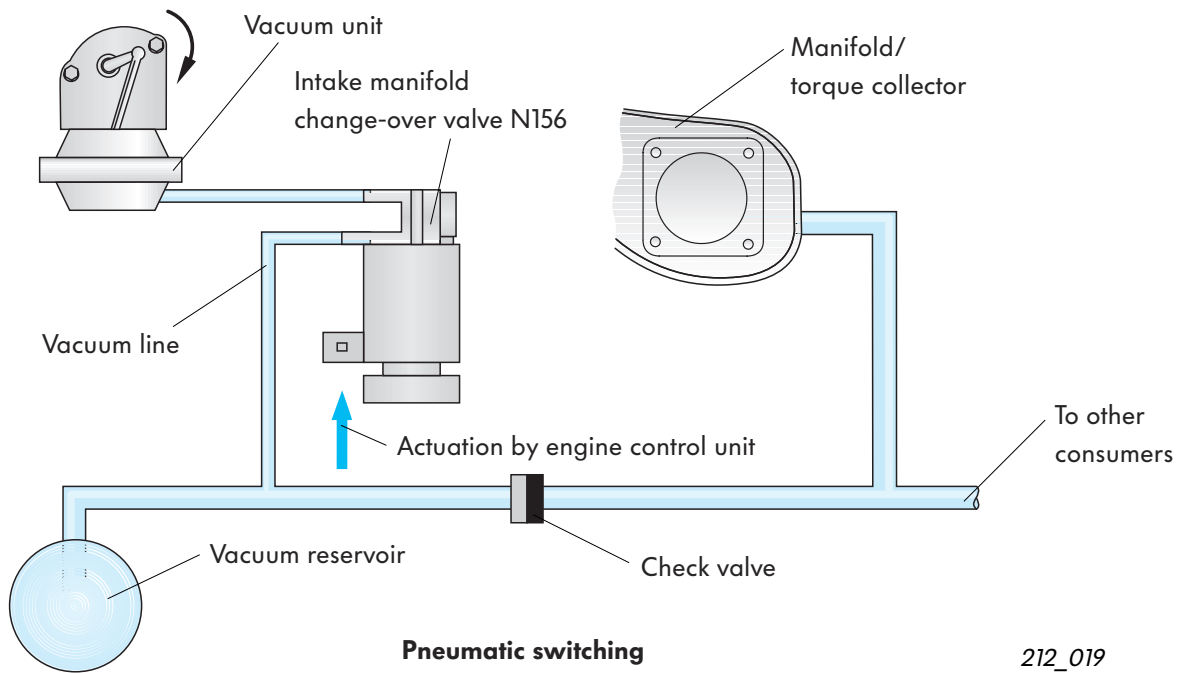

Changing pipes is done pneumatically with vacuum.

The pneumatic actuation is controlled by the engine control unit via the intake manifold change-over valve N156 (solenoid valve).

The vacuum is taken from the manifold torque collector.

Vacuum is stored in the vacuum reservoir and a check valve prevents the release of the vacuum.

The change-over barrel is in the power position, that is, the intake path is short, when the engine is not running or running at idle. It is held in this position by a compression spring.

The intake manifold change-over valve blocks the vacuum to the vacuum unit. When the intake manifold change-over valve is actuated, vacuum is released to the vacuum unit.

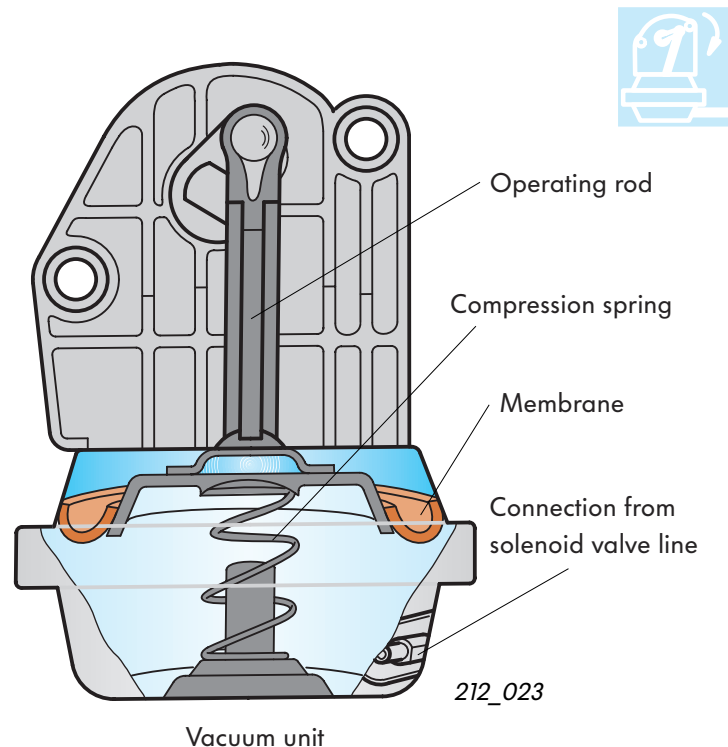

The tension of the compression spring is overcome and the membrane together with the connecting rod is pulled downwards. The change-over barrel is rotated 90°. The torque position comes into effect.



Intake manifold change-over

Intake manifold change-over valve N156

Function

The intake manifold change-over valve is a solenoid valve.

It is controlled by the engine control unit and depends on load and engine speed.

Atmospheric pressure acts on the magnet which forms the valve.

Together with the rubber valve plate, it blocks the vacuum line to the vacuum unit.

When the solenoid is actuated, the magnet is raised and the vacuum line is opened.

A foamed plastic filter at the entrance for atmospheric air pressure prevents the penetration of dirt particles which could impede the movement of the valve.

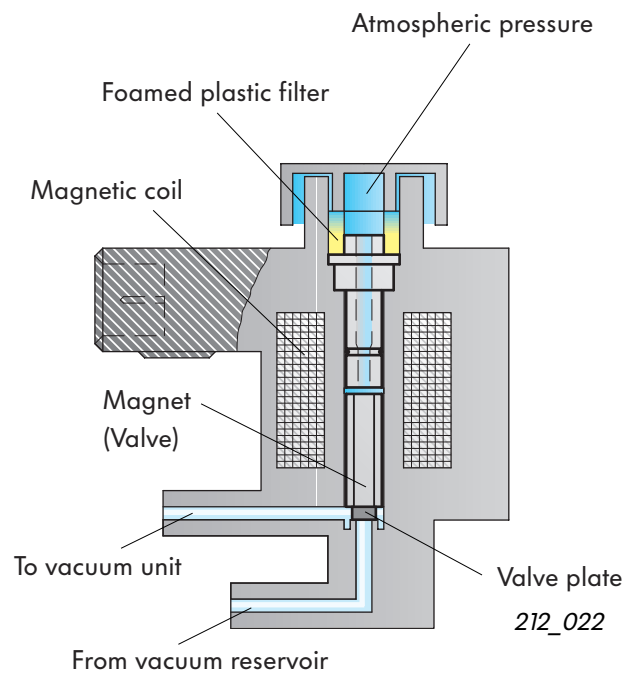

Emergency operation

If there is no signal, the vacuum line to the vacuum unit remains closed. The shorter intake path in the variable intake manifold remains open. A substitute function is not planned.

Self-diagnosis

Self-diagnosis is performed with the following functions:

- 02 - Interrogate fault memory
 - Short to earth
 - Short to positive
 - Open circuit
- 03 - Final control diagnosis

Electrical circuits

- J17 Fuel pump relay
- J220 Engine control unit
- N156 Intake manifold change-over valve
- S Fuse

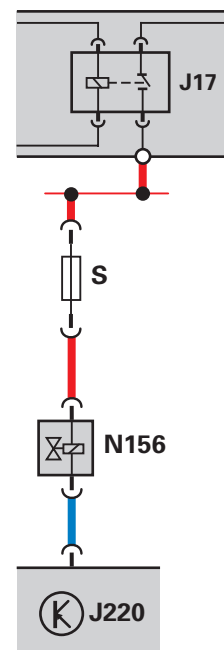

212_001

The variable intake manifold and its actuator are service-free.

If the engine is shown to have power deficits, the operation of the variable intake manifold is easy to test:

- Via **self-diagnosis**
The intake manifold change-over valve data is available under the functions 02 - Read out fault memory and 03 - Final control diagnosis.
- **Visual inspection** of the 90° rotation at the vacuum unit with the help of the engine speed.

Knowledge of the operation of the variable intake manifold helps as well.

Important:

When the engine is not running or running at idle, the change-over barrel is in position for the shorter intake path, or power position.

Bear in mind:

Differing change-over concepts

= with additional change-over point; up to 1100 rpm in power position, then change-over to torque position and at 4200 rpm back to power position.

= load dependent change-over; with throttle burst under full load below 4000 rpm, change-over to torque position.

Checking change-over movement with vacuum using hand vacuum pump V.A.G 1390.



Please refer to the current workshop manual for exact instructions for all tests.

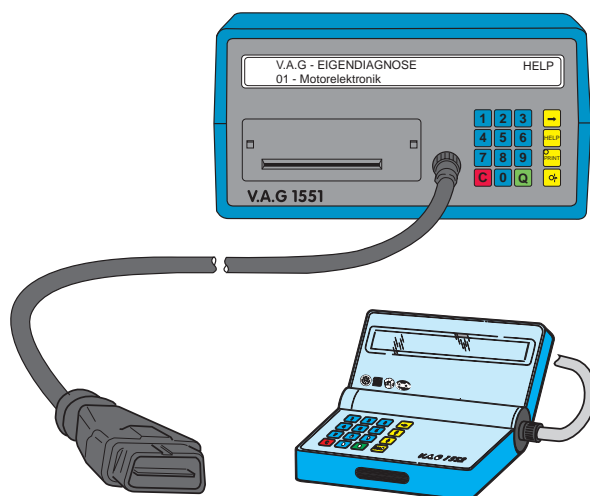

203_026

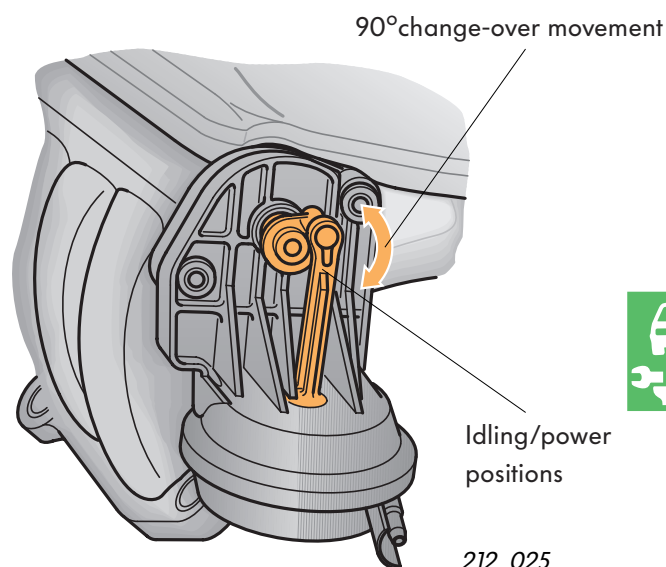

212_025

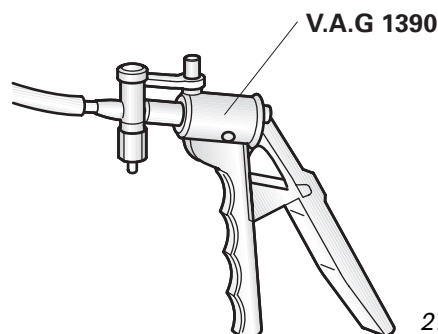

212_027

Test you knowledge

Which answers are correct?

Sometimes just one.

But sometimes several or all answers may be correct!

Fill in the blanks:



212_024

1. The "ram-effect charging" of a petrol engine is determined by the engine speed and the period that the inlet valve is open.
The first principle can be derived from this:

The the engine speed, the the intake pipe length.
2. Consequently, the first principle is the basis for the concept of a variable change-over intake manifold

with intake pipes in the low engine speed range
for
with intake pipes in the high engine speed range
for power production.
3. The volumetric efficiency VE makes a statement
 - A. about the fuel/air mixture.
 - B. about the fuel/oxygen mixture.
 - C. about air supply with ratio of the actual air mass in the cylinder to the theoretical air mass in the cylinder.
4. One characteristic of the variable intake manifold on the VR engines is the change-over barrel. It
 - A. lies transverse before all torque pipes.
 - B. opens the path to the torque pipes when it is actuated.
 - C. creates with its passages the connection from the power pipes to the power collector when actuated.



5. What is joined directly to the torque collector?
- A. the torque pipes
 - B. the power pipes
 - C. special pipes to supply the power pipes
6. The high torque achieved with the variable intake manifold permits frequent use of upper gears in low and middle engine speed ranges without loss of pulling power.
- A. This improves the service life of the change-over barrel because it is operated less.
 - B. This is bad for the operation of the change-over barrel because it is operated less.
 - C. Frequent change-over motion is good for the self-cleaning of the change-over barrel. Therefore the change-over concept was extended by an additional change-over point in the low engine speed range.
7. The change-over barrel is supported.
It is operated
The influences torque.
8. The actuator for operating the change-over barrel is a vacuum unit.
- A. A compression spring in the vacuum unit holds the change-over barrel in the power position.
 - B. A compression spring in the vacuum unit holds the change-over barrel in the torque position.
 - C. Actuating the vacuum unit switches the manifold to the power position.



Answers

1. higher, shorter; 2. long, high torque production, short; 3. C; 4. C; 5. A; 6. B, C;
7. elastically, pneumatically, radial air gap; 8. A