

Engine, disassembling and assembling

Note:

- ◆ When working on the engine it should be secured to assembly stand VW 313 using engine bracket 3269 or VW 540 and supplement set 540/1 B.
- ◆ If when repairing engine, metal shavings or large amounts of small metal particles are found in the engine oil, caused by partial seizure of crankshaft or conrod bearings perform the following work sequences to prevent consequential damage once repairs are complete:
 - - Thoroughly clean oil passages
 - - Replace oil spray jets
 - - Replace oil cooler
 - - Replace oil filter
 - - Replace oil non-return valve

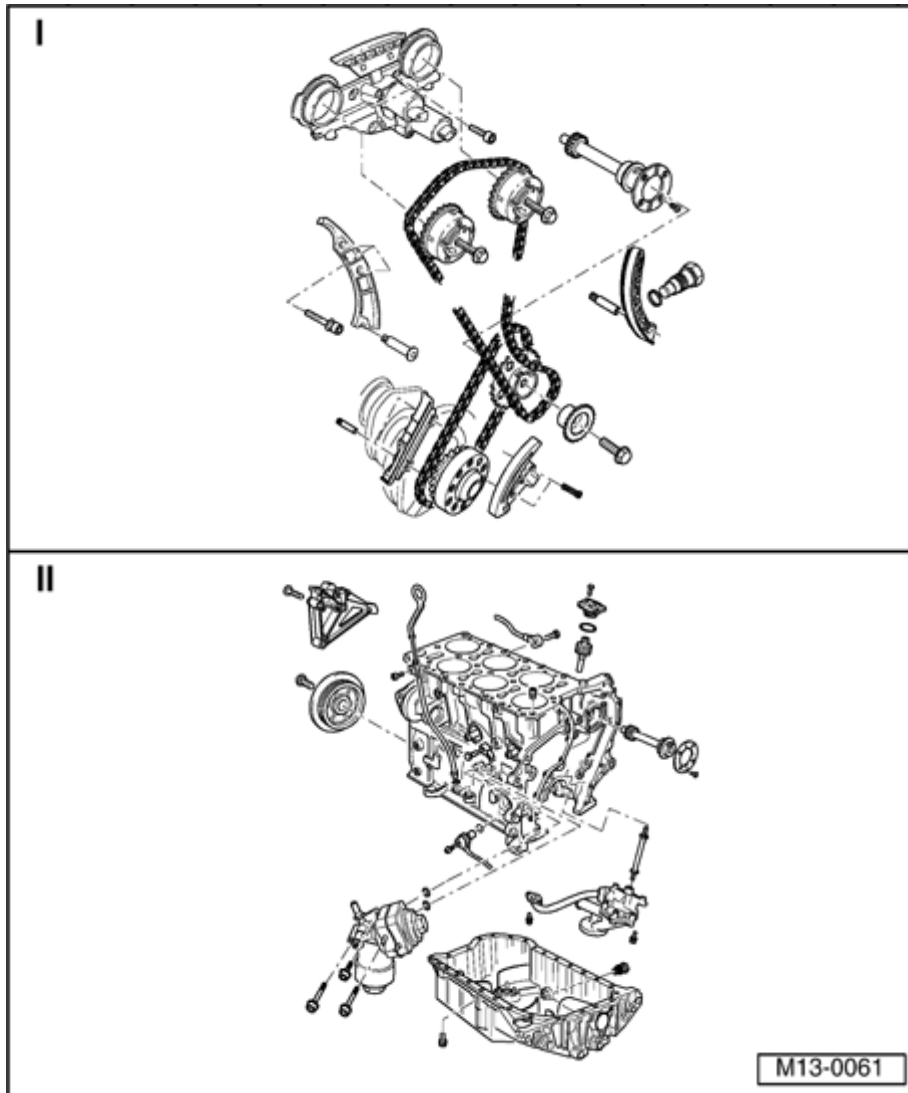

I ⇒ [Page 13-3](#)

II ⇒ [Page 13-12](#)

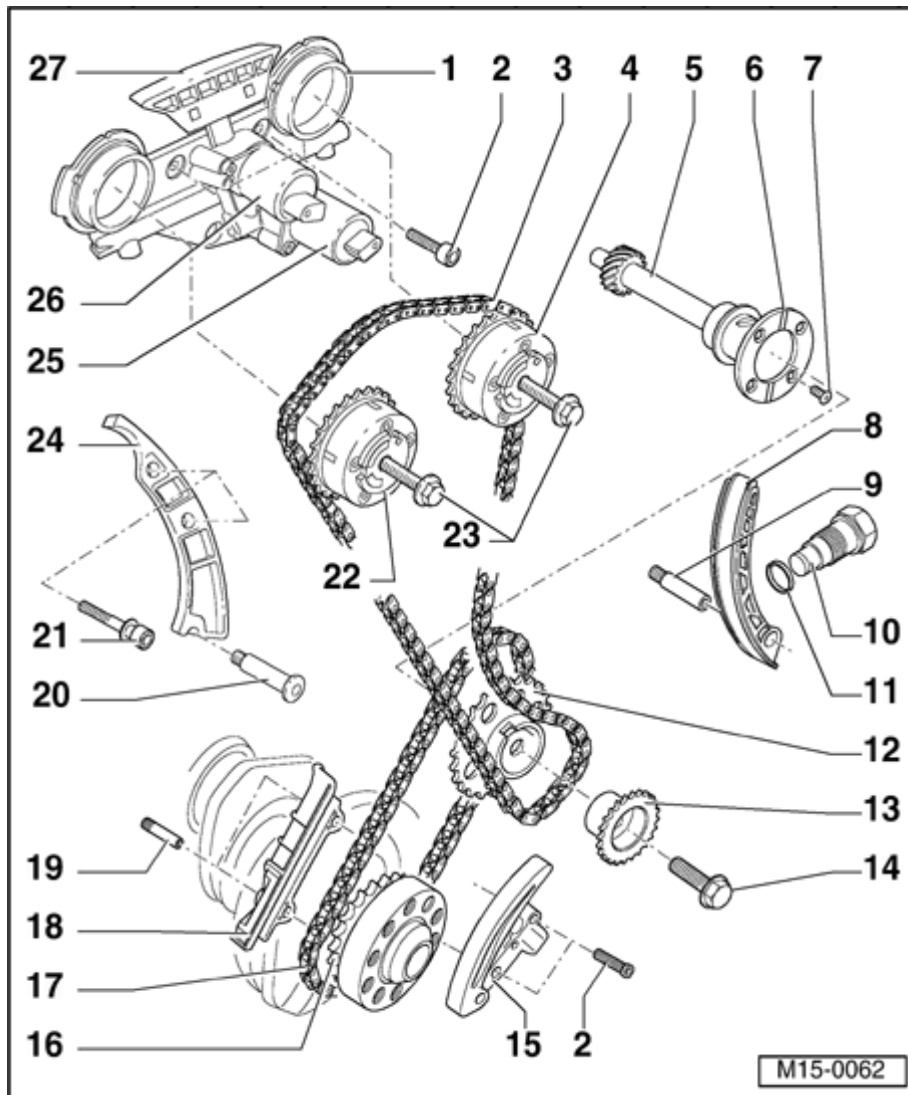

Part I

1 - Control housing

- ◆ Lubricate contact surfaces of oil seal when installing
- ◆ Removing and installing ⇒ [Page 15-69](#), Removing and installing camshaft
- ◆ Disassembling and assembling ⇒ [Page 15-64](#), Fig. 6
 - ◆ Check screen of control housing for soiling before installing ⇒ [Page 15-64](#), Fig. 7

2 - 8 Nm

- ◆ Replace

3 - Camshaft roller chain

- ◆ Mark direction of rotation before removing (installation)

position) ⇒
[Fig. 1](#)

- ◆ Installing
⇒ [Page 15-39](#) ,
Adjusting
valve
timing

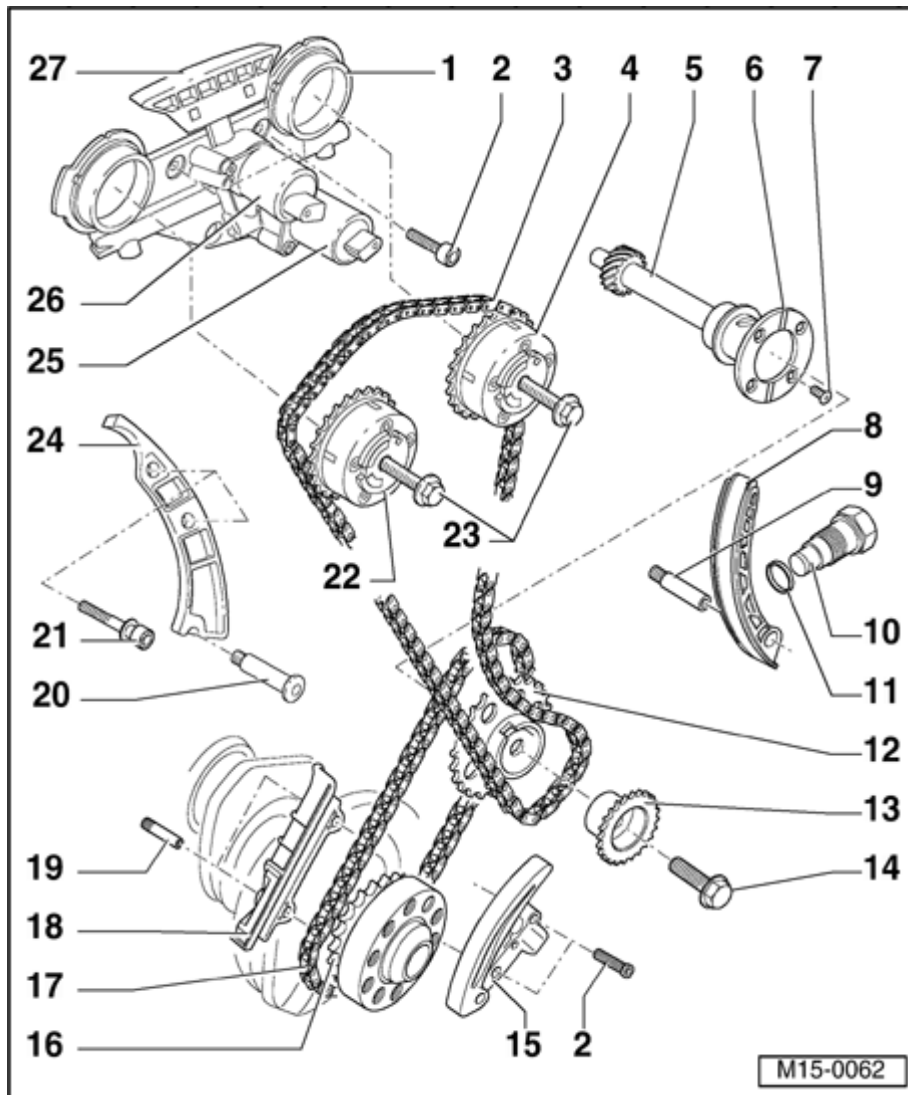

4 - Exhaust camshaft timing adjuster

- ◆ Marking: 32A
- ◆ Turn engine over only when camshaft timing adjuster is installed

- ◆ Check camshaft timing adjustment ⇒ [Page 15-82](#)

- ◆ Installing ⇒ [Page 15-39](#) , Adjusting valve timing

5 Intermediate - shaft

6 - Thrust washer

7 - 8 Nm

- ◆ Insert with locking compound D 000 600 A2

8 - Tensioning plate

- ◆ For camshaft roller chain item 3

**9 - Mounting
stud, 10
Nm**

- ◆ For
tensioning
plate item
8

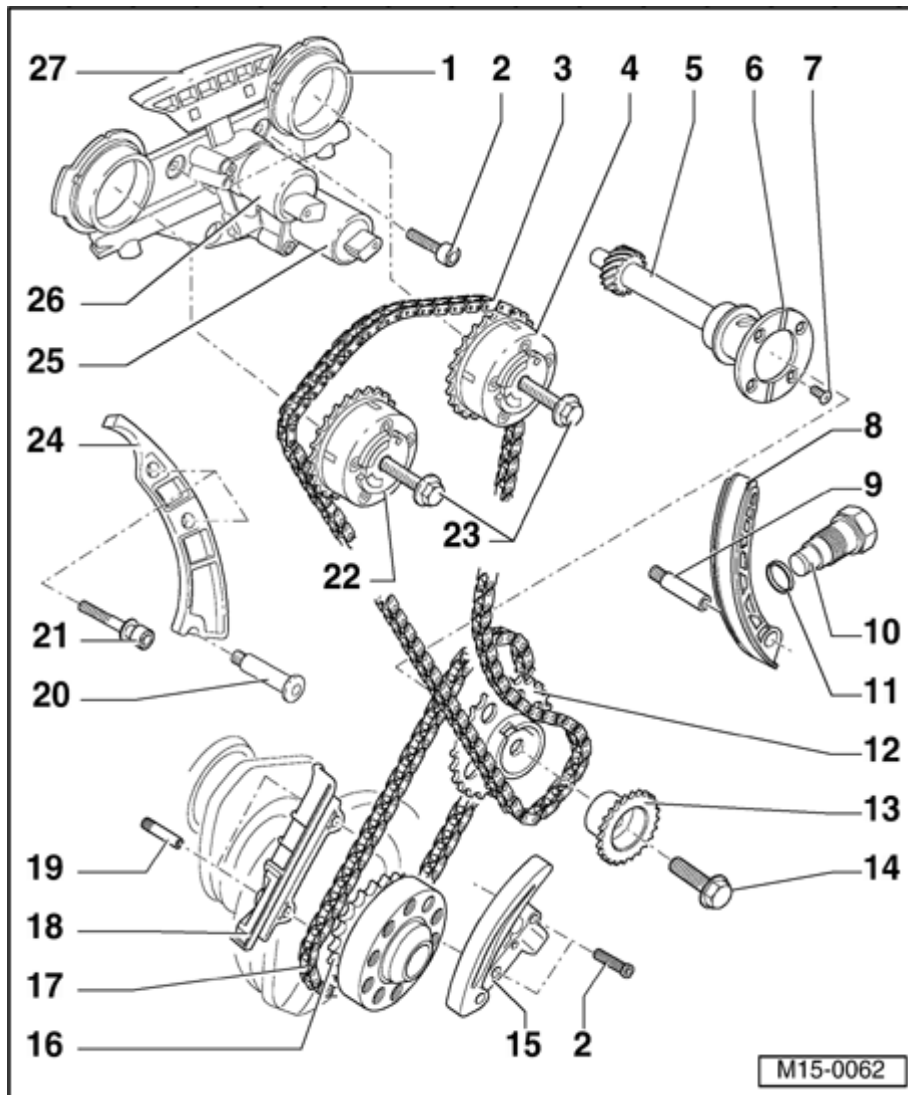

10 Chain - tensioner, 40 Nm

- ◆ For camshaft roller chain item 3
- ◆ Turn engine over only when chain tensioner is installed

11 - Seal

- ◆ Replace if damaged or leaking

12 - Chain sprocket

- ◆ For roller chain item 17
- ◆ Installing ⇒ [Page 15-39](#), Adjusting valve timing

13 - Chain sprocket

- ◆ For camshaft roller chain item 3
- ◆ Installing ⇒ [Page](#)

[15-39](#) ,
Adjusting
valve
timing

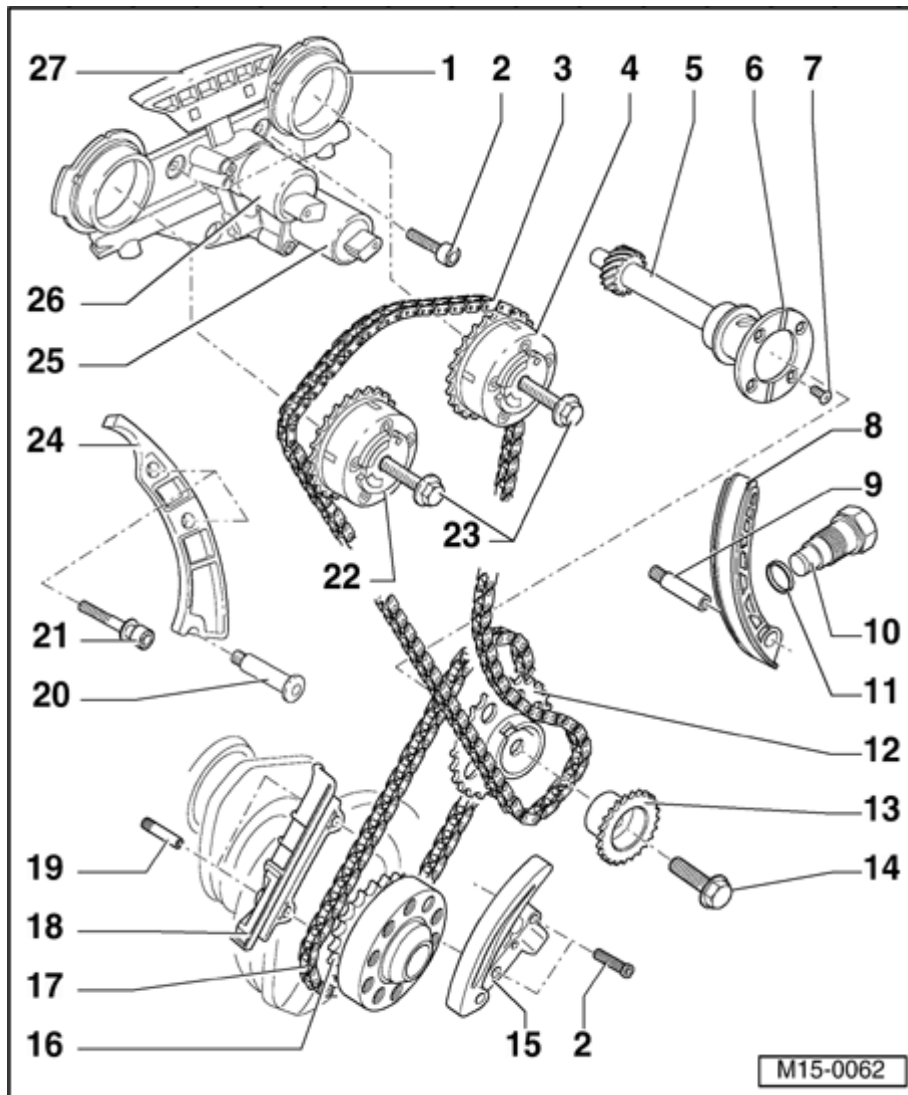

14 60 Nm
- plus
additional
1/4 turn
(90 °)
further

◆ Replace

◆ Use counter support T10069 to loosen and tighten ⇒ [Page 15-39](#), Adjusting valve timing

15 Chain
- tensioner
with
tensioning
rail

◆ For roller chain item 17

◆ Before installation release the locking device in the chain tensioner with a small screwdriver and press the tensioning plate against the chain tensioner

- ◆ Turn engine over only when chain tensioner is installed

16 - Drive sprocket

- ◆ Integral part of crankshaft
- ◆ Ground down tooth aligned with main bearing joint = TDC cyl.
1 ⇒ [Page 15-39](#) , Adjusting valve timing

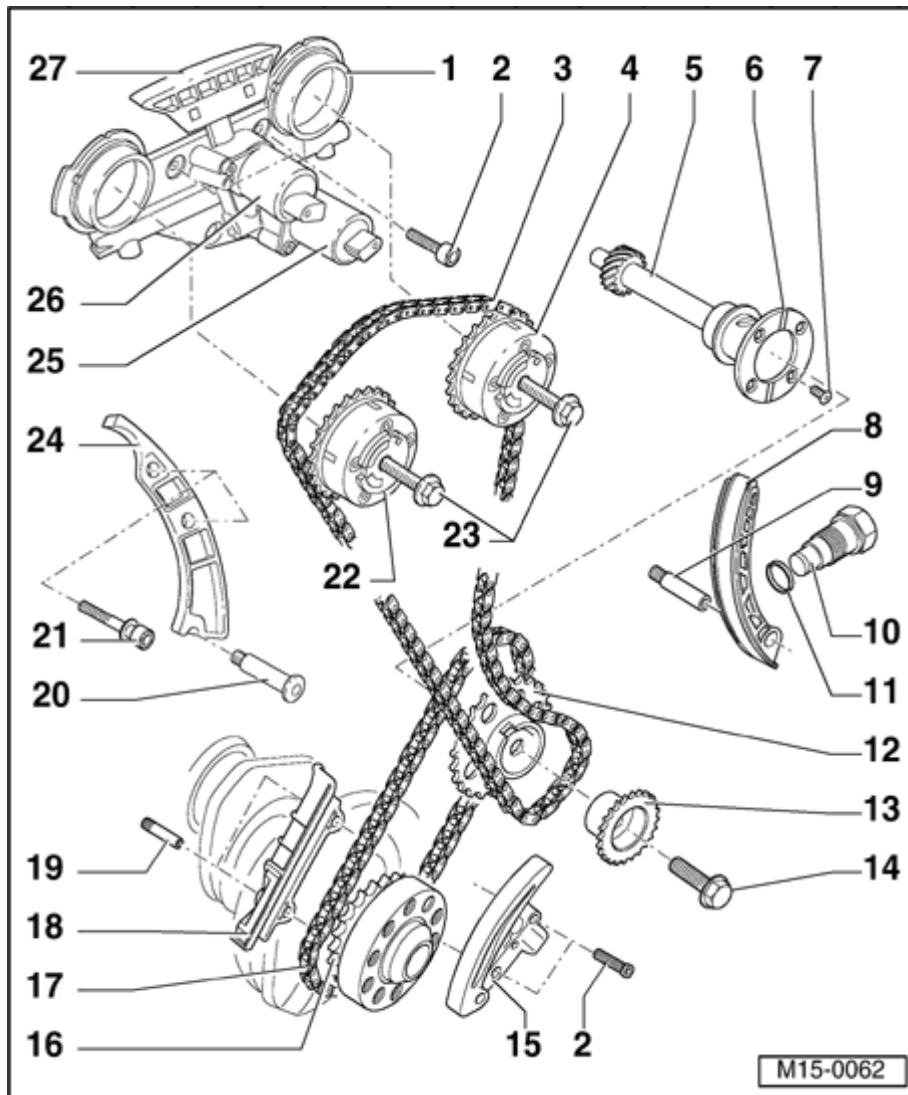

17 - Roller chain

◆ Mark direction of rotation before removing (installation position) ⇒ [Fig. 1](#)

◆ Installing ⇒ [Page 15-39](#), Adjusting valve timing

18 - Guide rail

◆ For roller chain item 17

◆ Remove and install together with roller chain ⇒ [Page 15-39](#), Adjusting valve timing

19 - Stud without collar, 10 Nm

◆ For guide rail item 18

20 - 10 Nm

◆ For
guide
rail
item
24

21 - 23 Nm

◆ For
guide
rail
item
24

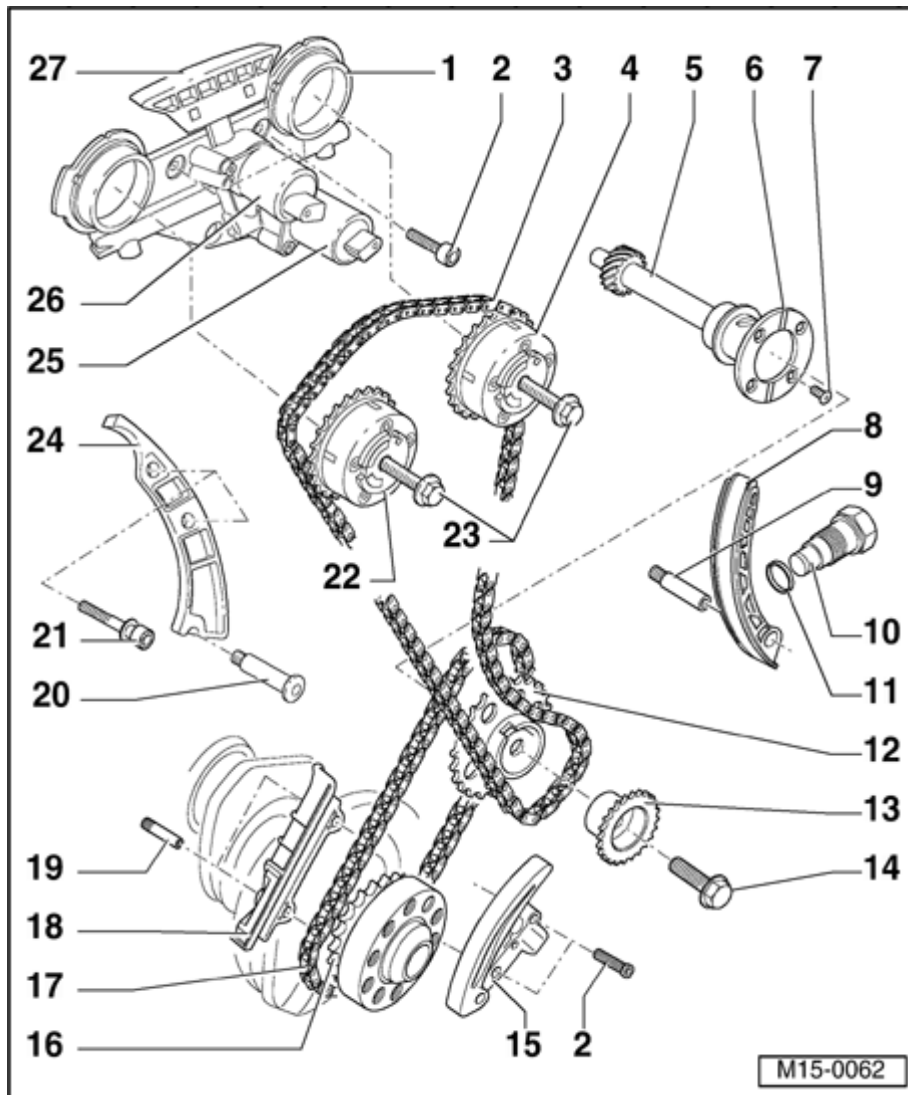

**22 Intake
- camshaft
timing
adjuster**

- ◆ Marking:
24E
- ◆ Turn engine over only when camshaft timing adjuster is installed
- ◆ Check camshaft timing adjustment ⇒ [Page 15-82](#)
- ◆ Installing ⇒ [Page 15-39](#) , Adjusting valve timing

**23 60 Nm
- plus
additional
1/4 turn
(90°)
further**

- ◆ Replace
- ◆ Contact surface of sensor wheel on bolt head must be dry for assembly
- ◆ To remove

and
install,
use a 32
mm open
jaw
spanner
on
camshaft
to counter
support
⇒ [Page
15-69](#) ;
Removing
and
installing
camshaft

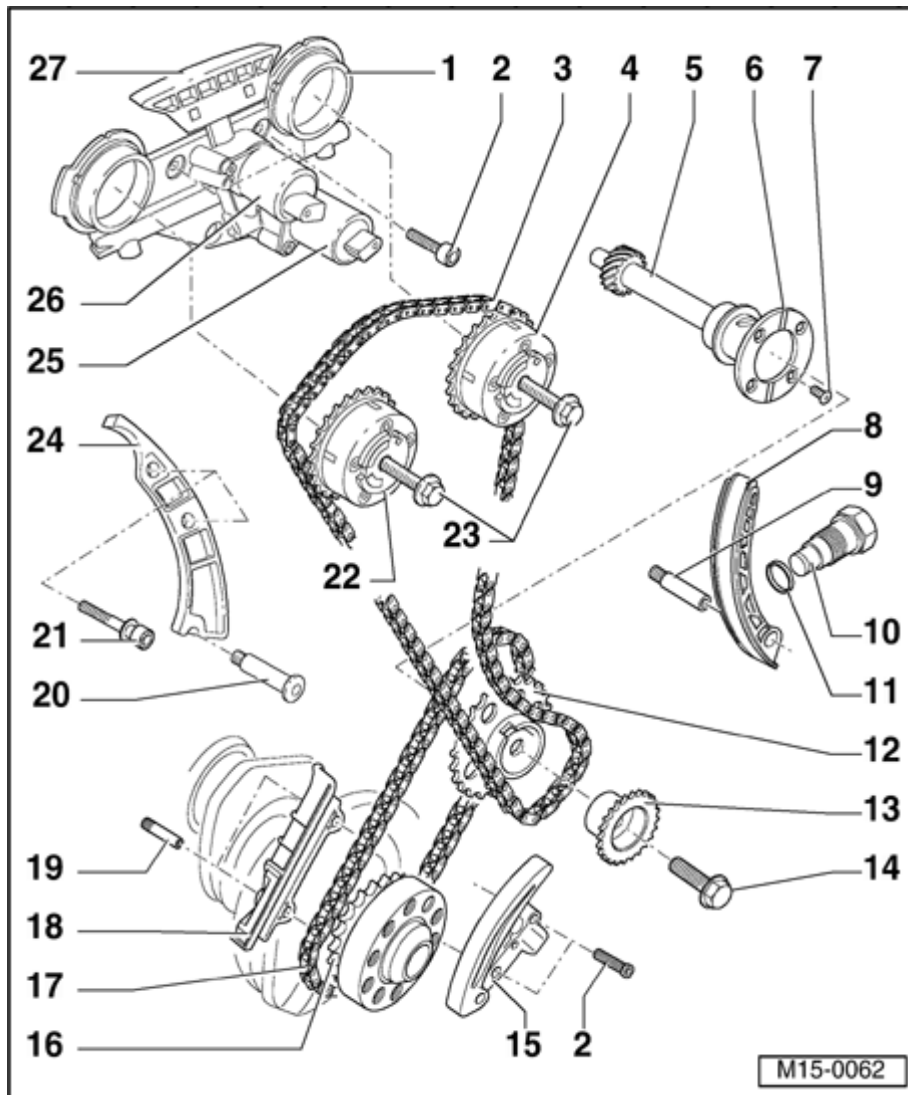

24 - Guide rail

- ◆ For camshaft roller chain item 3

25 Camshaft - adjustment valve 2 (exhaust) - N318-

- ◆ Check camshaft timing adjustment ⇒ [Page 15-82](#)
- ◆ Mark connector and component before pulling connector off
- ◆ Checking activation:

⇒ [Repair Manual, 2.8 Liter VR6 4V Fuel Injection & Ignition, Engine Code\(s\): BDF, Repair Group 01](#)

26 Valve 1 for - camshaft adjustment -N205-

- ◆ For intake camshaft
- ◆ Check camshaft

timing
adjustment
⇒ [Page
15-82](#)

◆ Mark
connector
and
component
before
pulling
connector
off

◆ Checking
activation:

⇒ [Repair
Manual, 2.8
Liter VR6 4V
Fuel Injection &
Ignition, Engine
Code\(s\): BDF,
Repair Group
01](#)

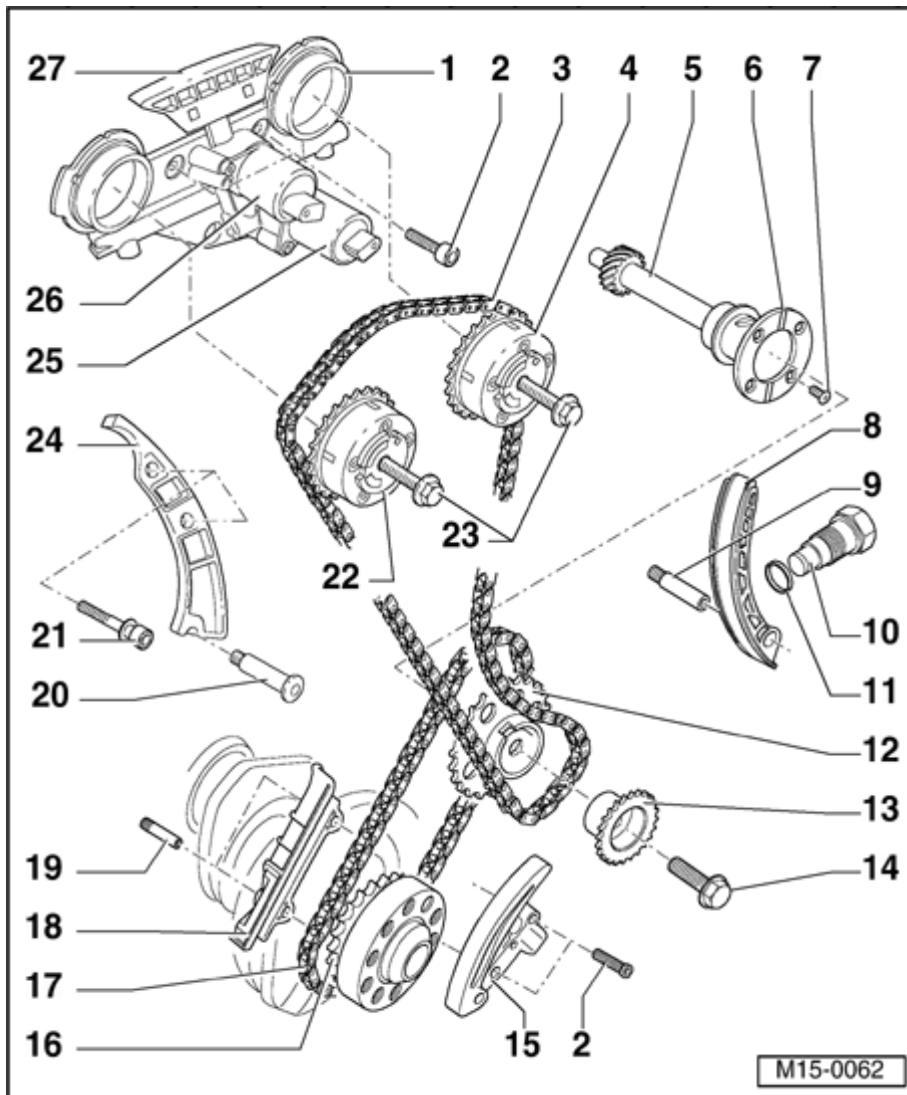

27 - Guide rail

- ◆ For camshaft roller chain item 3
- ◆ Clipped into control housing

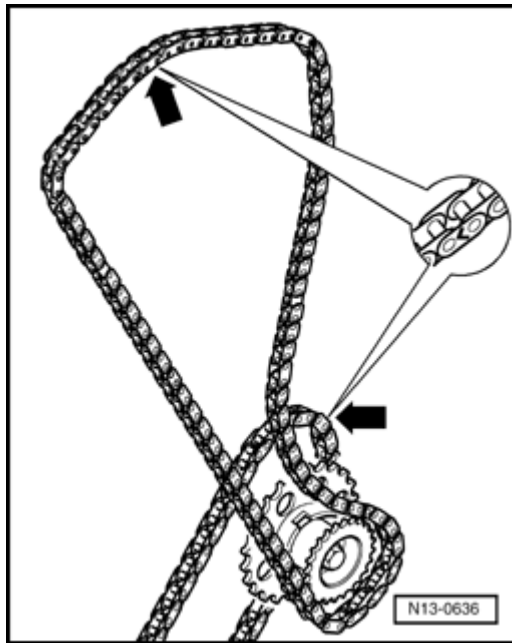
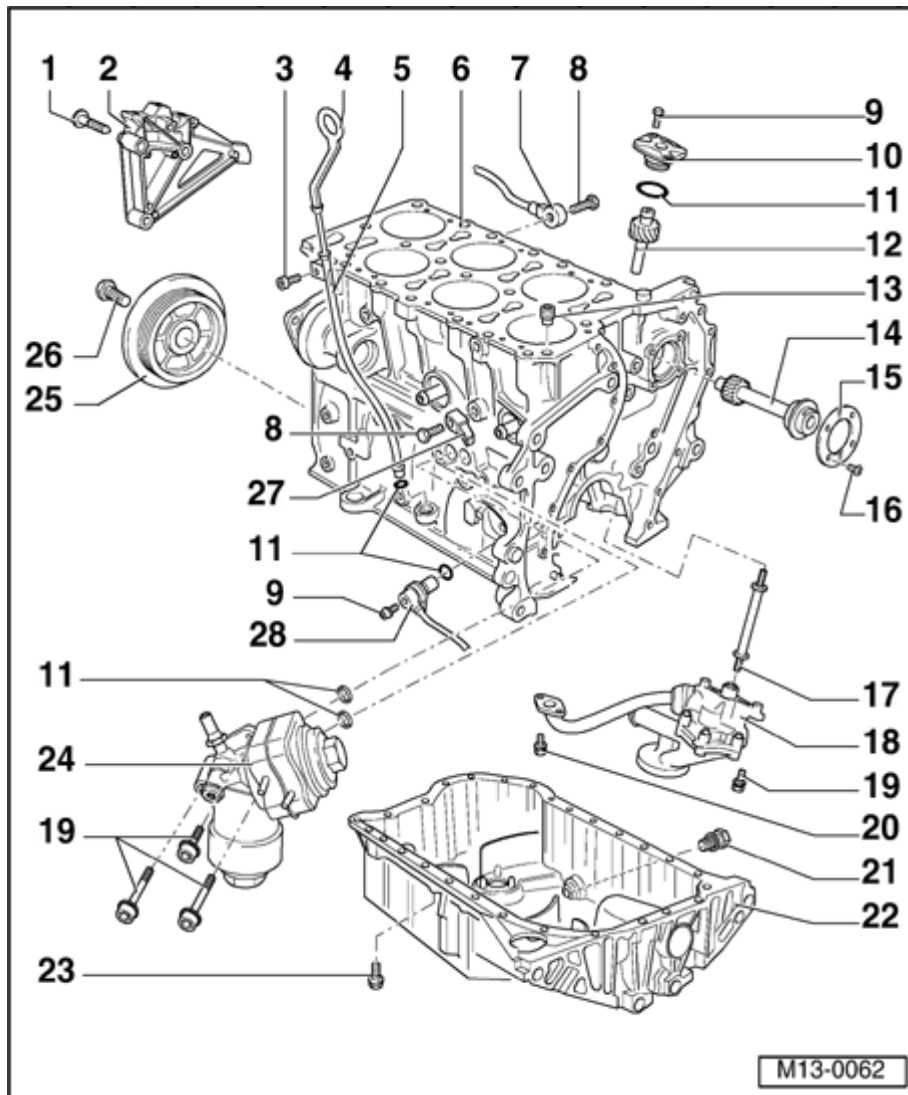

Fig. 1 Marking roller chains

- Mark roller chains before removing (e.g. with paint, arrow pointing in direction of rotation).

Note:

Do not mark chain with a punched mark, notch or similar!



Part II

1 - 45 Nm

2 - Engine bracket

3 - 8 Nm

◆ Secured to intake manifold

4 - Dipstick

◆ The oil level must not exceed the max. mark!

◆ Markings ⇒ [Page 17-8](#), Fig. 2

5 - Guide tube

◆ For dipstick

◆ Secured by a bolt to intake manifold

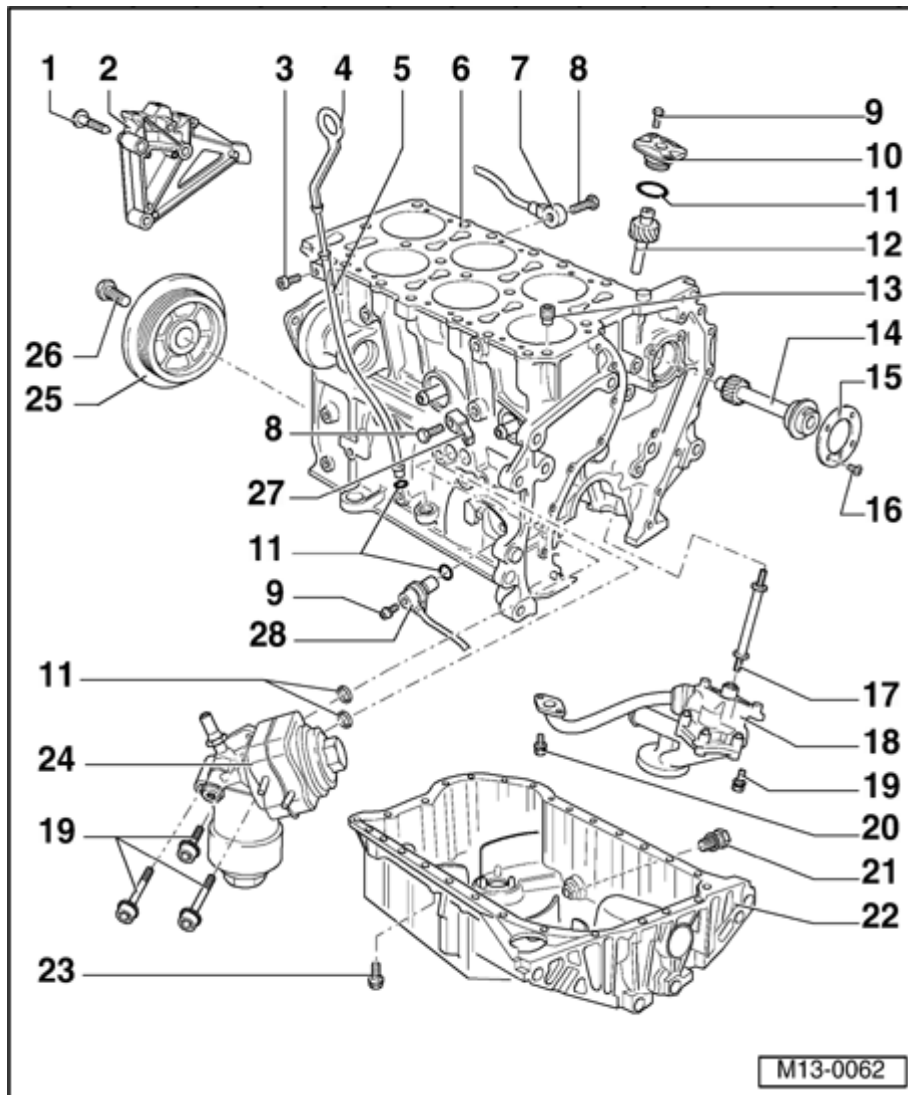

6 - Cylinder block

- ◆ Removing and installing sealing flange and dual-mass flywheel ⇒ [Page 13-22](#)
- ◆ Removing and installing crankshaft ⇒ [Page 13-34](#)
- ◆ Disassembling and assembling piston and conrod ⇒ [Page 13-39](#)

7 - Knock Sensor (KS) 1 - G61-

- ◆ 3-pin
- ◆ Installation location: Between cyl. 1 and cyl. 3
- ◆ The contact surfaces between knock sensor and cylinder block must be free of

corrosion,
dirt and
grease.

◆ Checking:

⇒ [Repair Manual,
2.8 Liter VR6 4V
Fuel Injection &
Ignition, Engine
Code\(s\): BDF,
Repair Group 01](#)

8 - 20 Nm

◆ Torque
setting
influences
the
function
of knock
sensor

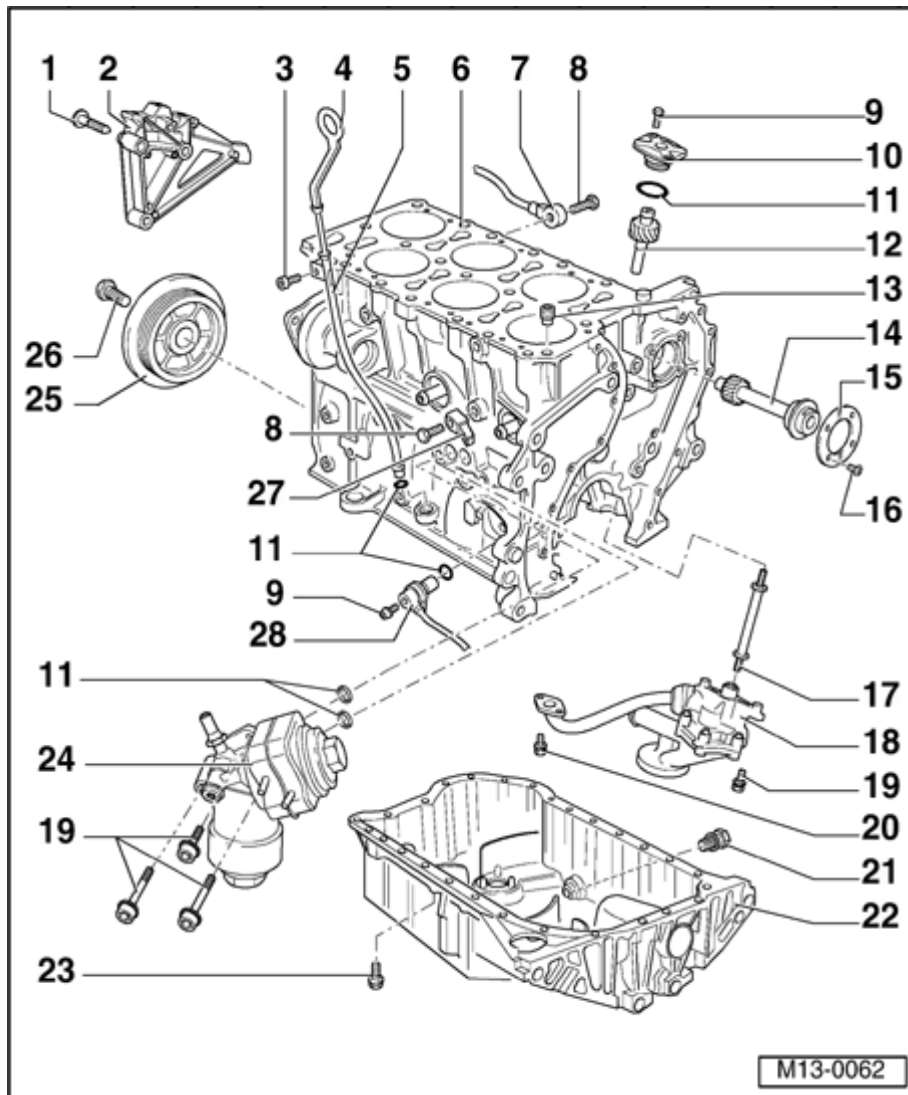

9 - 10 Nm

10 - Oil pump drive cover

11 - O-ring

◆ Replace

◆ Lubricate before installing

12 - Oil pump drive

13 - Oil non-return valve, 5 Nm

◆ Observe installation position

◆ Clean if badly soiled

◆ See note ⇒ [Page 13-1](#)

14 Intermediate - shaft

15 - Thrust washer

16 - 10 Nm

◆ Install with locking compound "D6"

17 - Drive shaft

◆ For oil pump drive

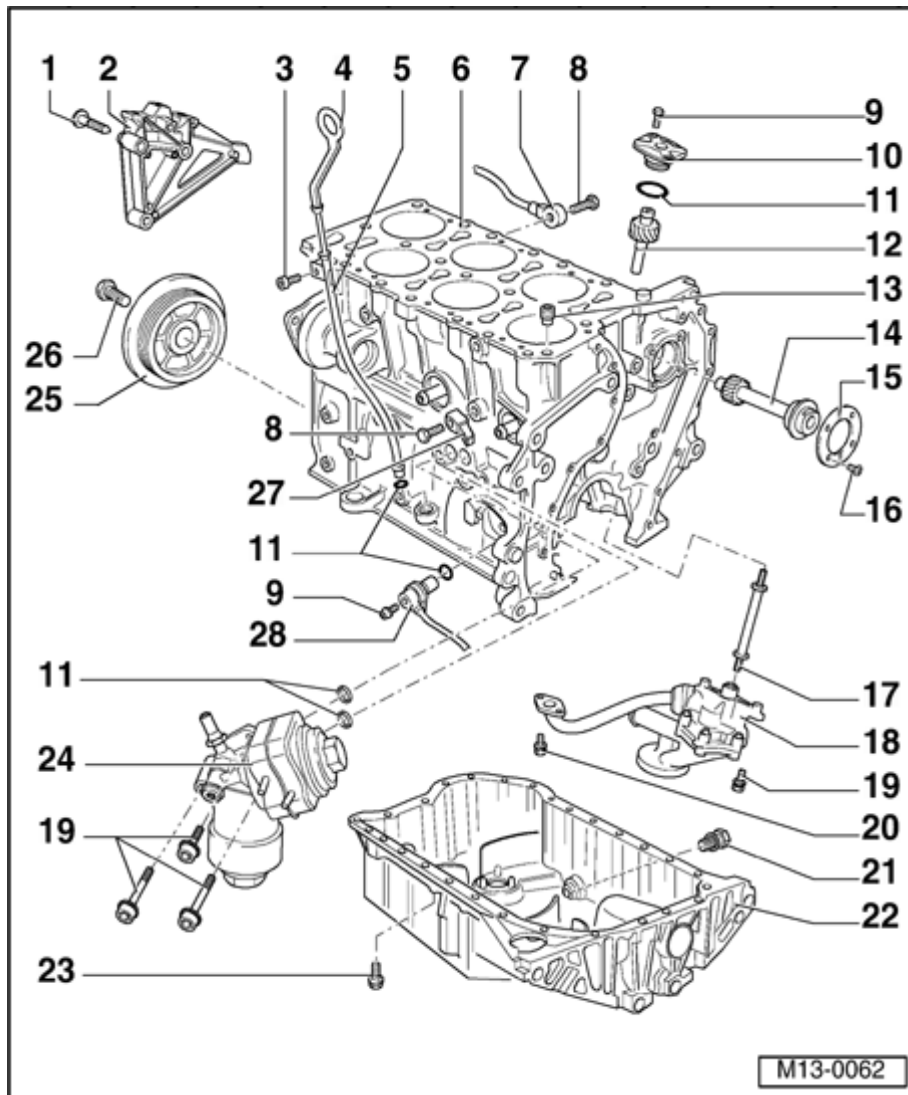

18 - Oil pump

◆ Disassembling and assembling ⇒ [Page 17-12](#)

- ◆ Coat oil pressure pipe at cylinder block and oil pump housing with sealing compound AMV 188 001 02

19 - 23 Nm

20 - 8 Nm

- ◆ Insert with locking compound D 000 600 A2

21 - Oil drain plug, 30 Nm

- ◆ Replace if leaking

22 - Oil pan

- ◆ Removing and installing ⇒ [Page 17-15](#)

23 - 12 Nm

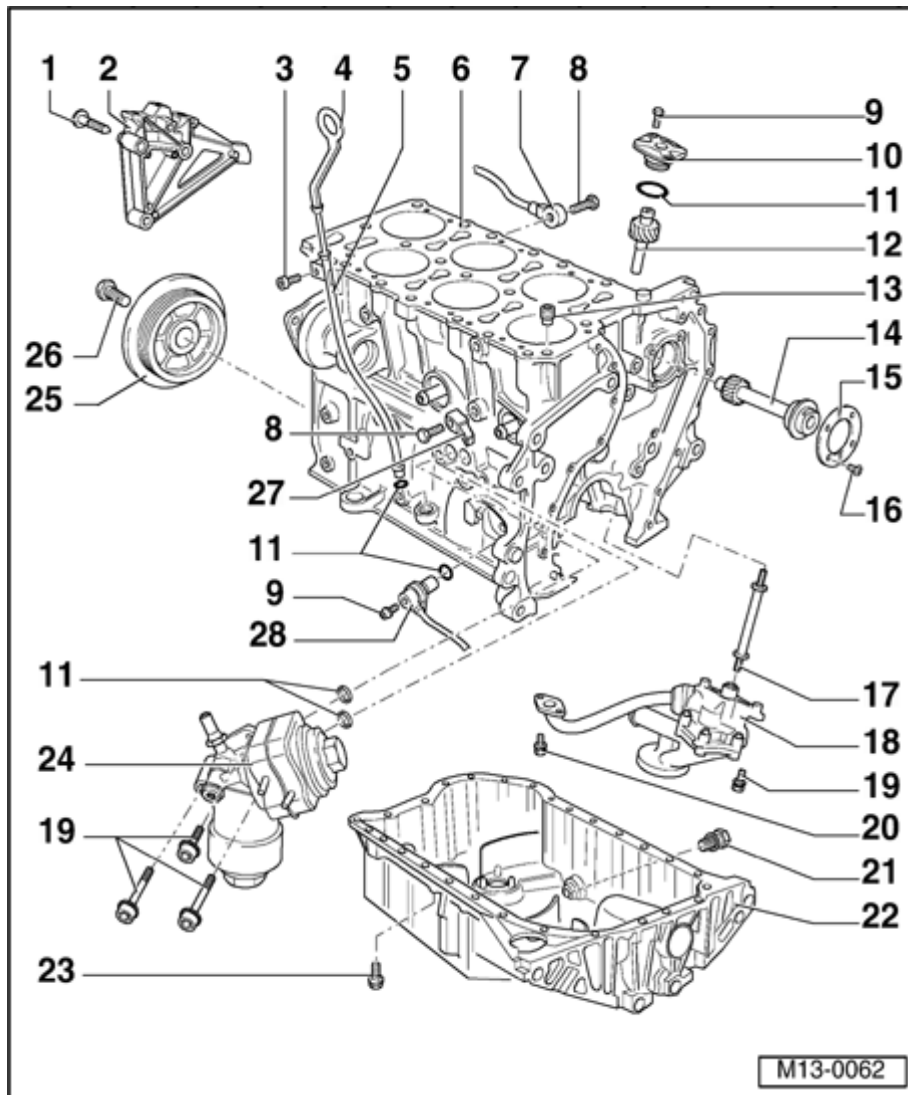

24 - Oil filter housing

- ◆ See note
⇒ [Page 13-1](#)
- ◆ Disassembling and assembling ⇒ [Page 17-9](#)
- ◆ Coolant hose connection diagram ⇒ [Page 19-11](#)

25 - Vibration damper

- ◆ Removing and installing ribbed belt ⇒ [Page 13-19](#)

26 - 100 Nm plus additional 1/4 turn (90°) further

- ◆ Replace
- ◆ Use counter support T10069 to loosen and tighten ⇒ [Fig. 1](#)
- ◆ Tighten using torque wrench VAG

1601

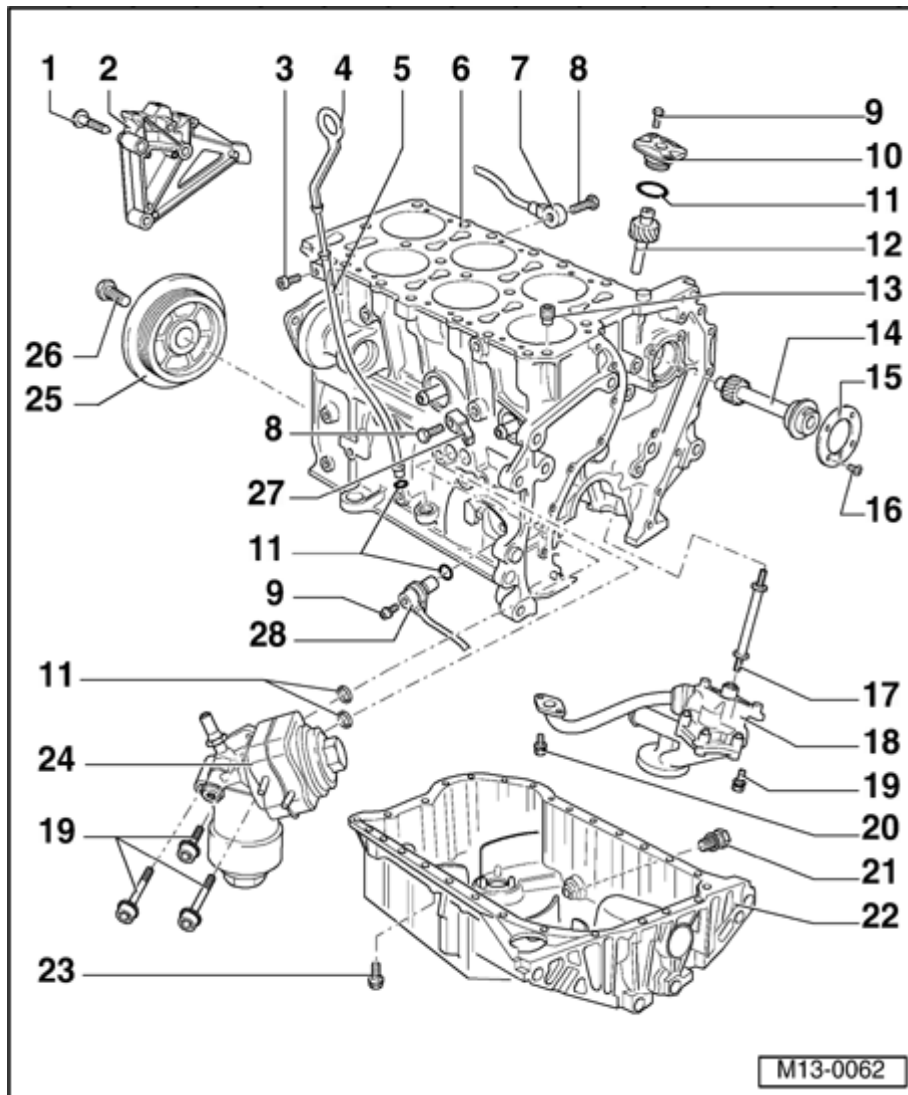

27 - Knock Sensor (KS) 2 - G66-

◆ 2-pin

◆ Installation location:
Between cyl. 4 and cyl. 6

◆ The contact surfaces between knock sensor and cylinder block must be free of corrosion, dirt and grease.

◆ Checking:

⇒ [Repair Manual, 2.8 Liter VR6 4V Fuel Injection & Ignition, Engine Code \(s\): BDF, Repair Group 01](#)

28 - Engine speed (RPM) sensor -G28-

◆ Checking:

⇒ [Repair Manual, 2.8 Liter VR6 4V Fuel Injection & Ignition,](#)

Engine Code
(s): BDF,
Repair Group
01

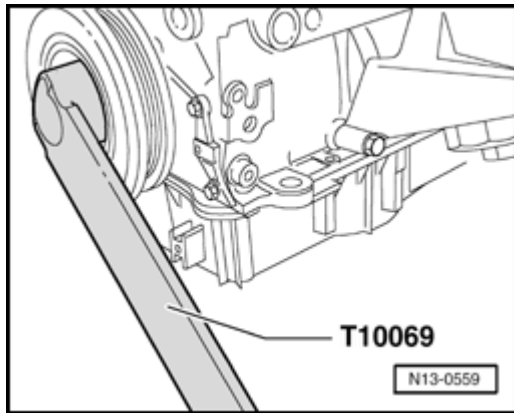

Fig. 1 To loosen and tighten securing bolt, hold vibration damper with counter support T10069

Note:

- ◆ *Vibration damper securing bolt must be replaced.*
- ◆ *Tighten securing bolt with torque wrench VAG 1601.*

Ribbed belt, removing and installing

Special tools and equipment

- ◆ VAS 5024 Assembly tool for spring-type clips
- ◆ Hex bolt M8x45

Removing ribbed belt

Note:

Mark ribbed belt direction of rotation before removing. Make sure ribbed belt is seated correctly in belt pulley when installing.

- Remove engine cover.

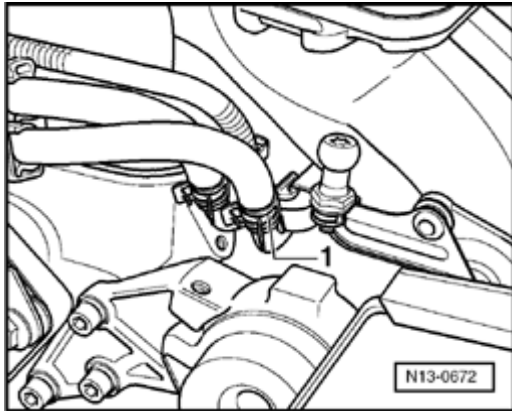

- ✦ - Pull off return hose -1- (with blue marking) and collect fuel that may leak out with a cloth.
- Seal lines to avoid contamination of fuel system.
- Observe rules for cleanliness ⇒ [Page 20-14](#) .
- Removing right hand insulation tray:

⇒ [Repair Manual, Body Exterior, Repair Group 50](#)

- Mark direction of rotation of ribbed belt.

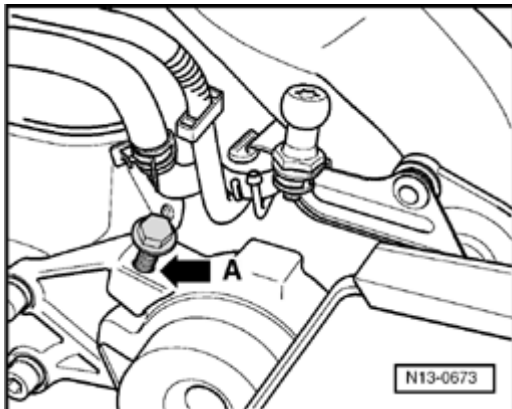

- ✦ - Screw M8x45 bolt into threaded hole -A- of tensioning element until ribbed belt is no longer under tension.

Note:

Screw bolt in sufficiently so that the ribbed belt can be removed and no further, otherwise the tensioner element housing may be damaged.

- Remove ribbed belt.

Installing ribbed belt

- Install in reverse order.

Note:

- ◆ *Make sure, before installing ribbed belt, ancillaries (alternator, air conditioning compressor, power steering pump) are s tightly.*
- ◆ *When installing the ribbed belt observe l direction of rotation and that the belt is s correctly in the belt pulleys.*

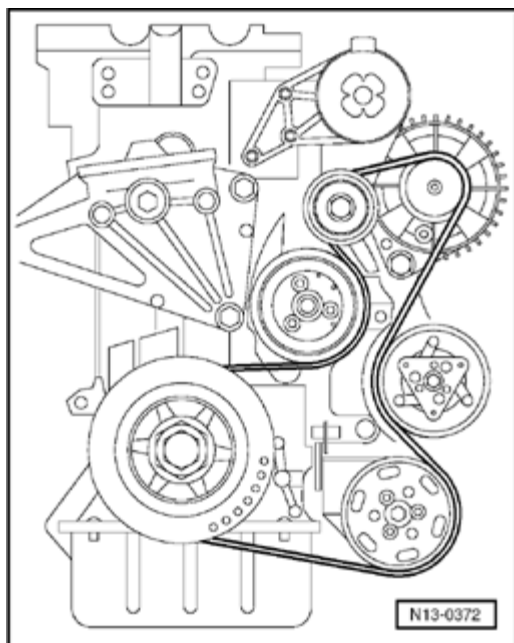

- Install ribbed belt.
- Remove M8 bolt from tensioner!

After completing repairs always:

- Start engine and check belt running.
- Install right-hand insulation tray:
⇒ [Repair Manual, Body Exterior, Repair Gr](#)
- Install engine cover.

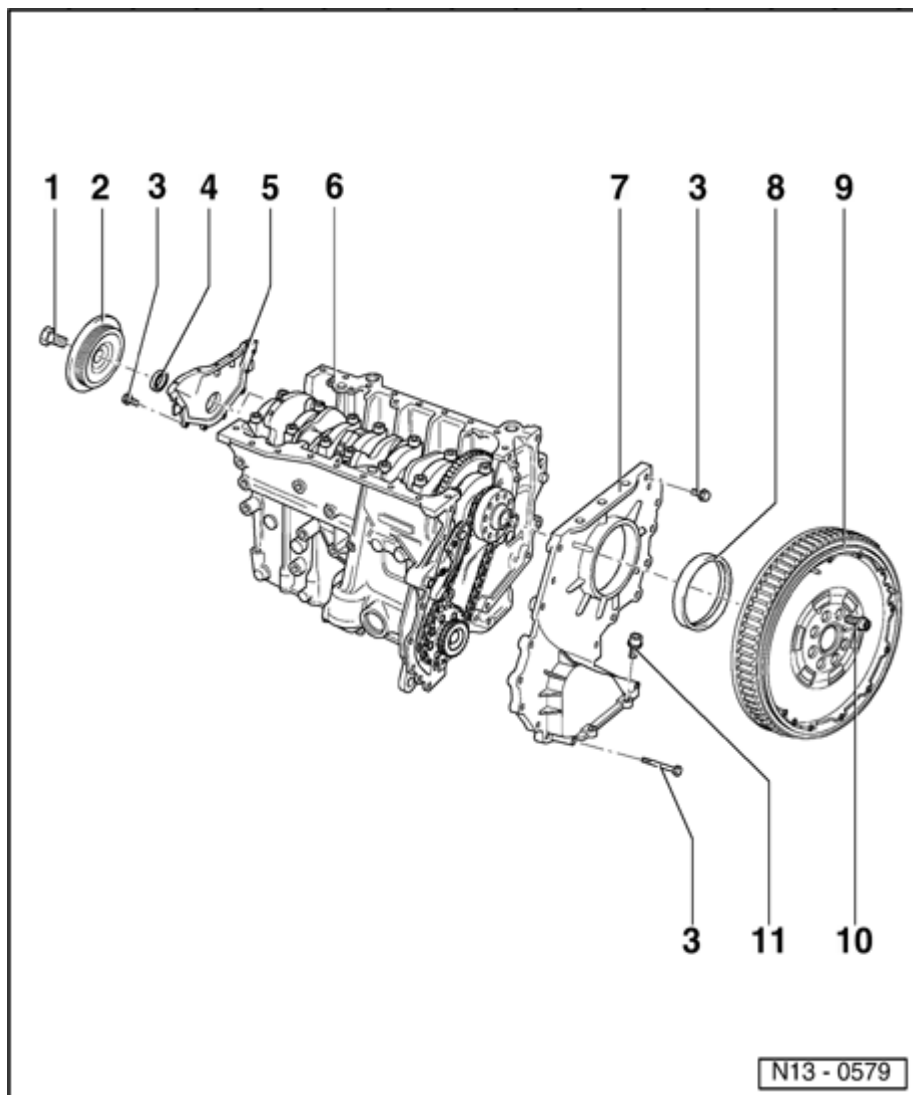

Sealing flanges and dual-mass flywheel, removing and installing

Note:

- ◆ Servicing clutch:

⇒ [Repair Manual, 5 & 6 Spd. Manual Transmission 02M, Repair Group 30](#)

- ◆ When working on the engine it should be secured to assembly stand VW 313 using engine bracket 3269 or VW 540 and supplementary set 540/1 B.
- ◆ The sealing flange (item 7) can be removed and installed when cylinder head is installed.

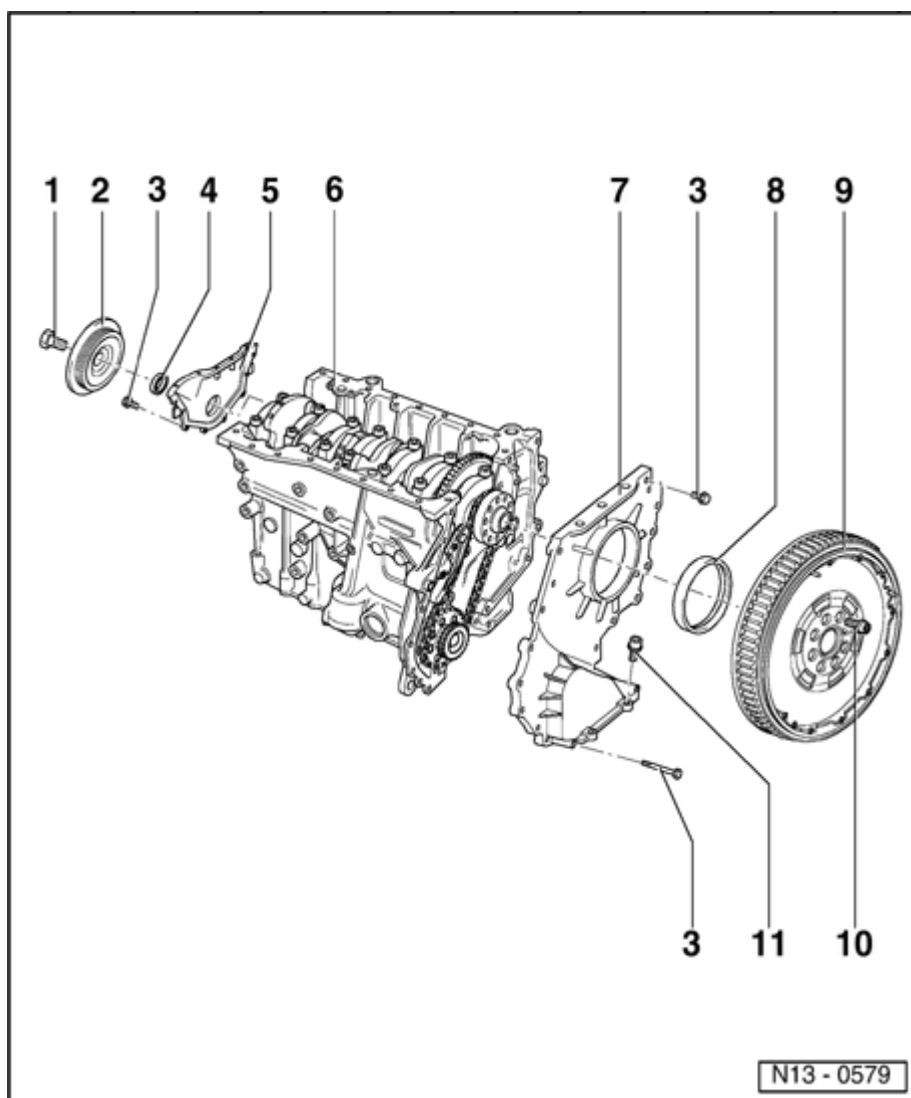

**1 - 100 Nm
plus
additional
 $\frac{1}{4}$ turn
(90°)
further**

◆ Replace

◆ Use counter support T10069 to loosen and tighten \Rightarrow [Page 13-27](#), Replacing crankshaft oil seal - vibration pulley end

◆ Tighten using torque wrench VAG 1601

2 - Vibration damper

◆ Removing and installing ribbed belt \Rightarrow [Page 13-19](#)

3 - 8 Nm

4 - Seal

◆ PTFE seal version

◆ Marking: With no inner

coil
spring

- ◆ Do not additionally lubricate the oil seal sealing lip
- ◆ Before installing, remove oil remains from crankshaft journal with a clean cloth
- ◆ Replacing
⇒ [Page 13-27](#)

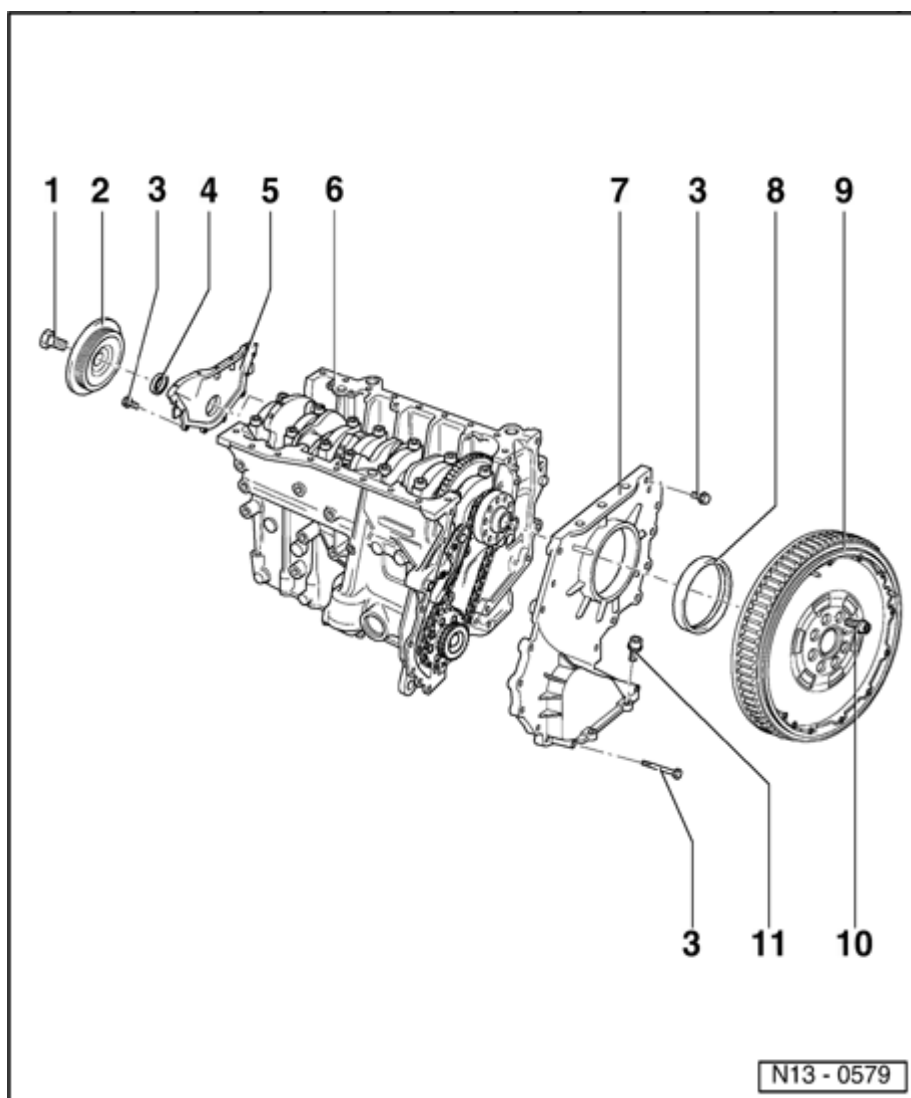

5 - Sealing flange

- ◆ Coat sealing surfaces with sealing compound AMV 188 001 02

6 - Cylinder block

- ◆ Removing and installing crankshaft ⇒ [Page 13-34](#)
- ◆ Disassembling and assembling piston and connecting rod ⇒ [Page 13-39](#)

7 - Sealing flange

- ◆ Coat sealing surfaces with sealing compound AMV 188 001 02
- ◆ Seal sealing surface to cover ⇒ [Page 15-39](#) , Adjusting timing

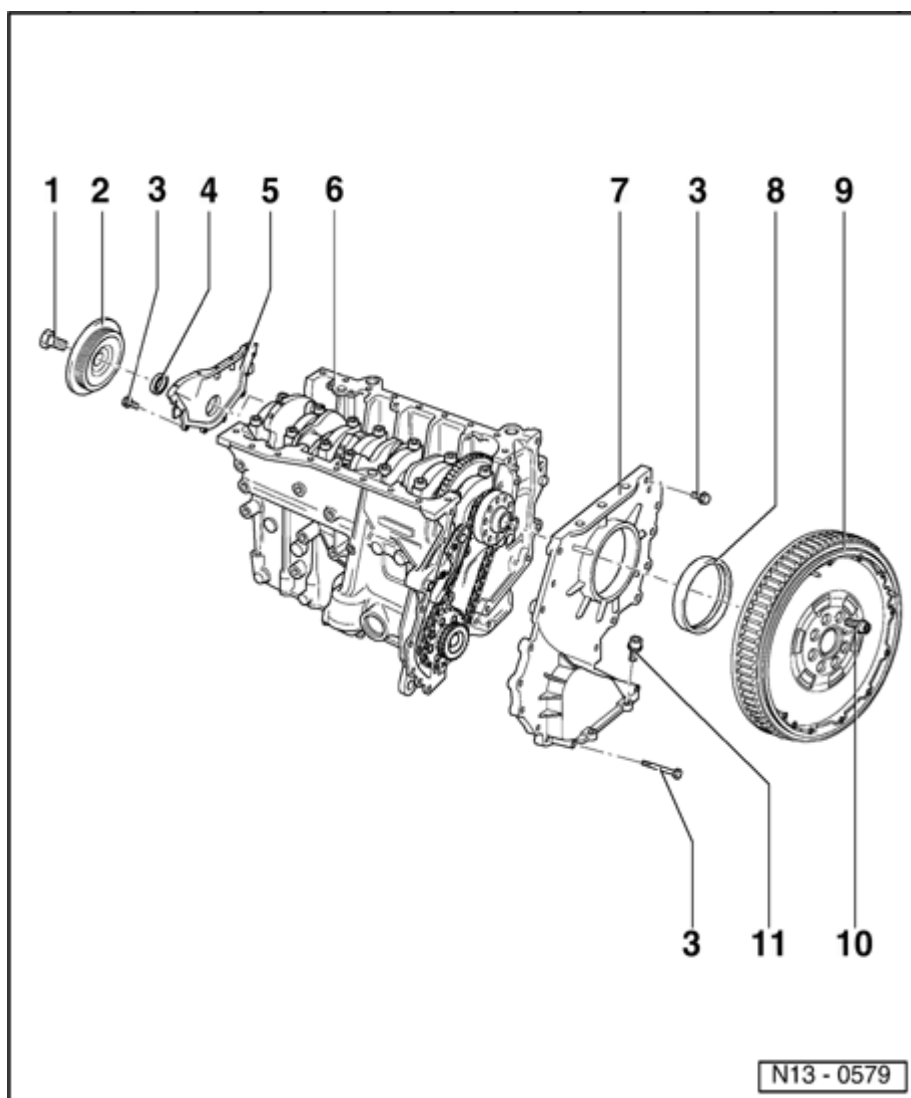

8 - Seal

- ◆ PTFE seal version
- ◆ Marking: With no inner coil spring
- ◆ Do not additionally lubricate the oil seal sealing lip
- ◆ Remove with extractor hook 2086
- ◆ Before installing, remove oil remains from crankshaft journal with a clean cloth.
- ◆ Install over sleeve 2003/2A
- ◆ Pull in onto limit stop with press sleeve 2003/1

9 Dual-mass - flywheel/drive plate

- ◆ Removing and installing

drive
plate ⇒
[Page 13-
31](#)

13-26

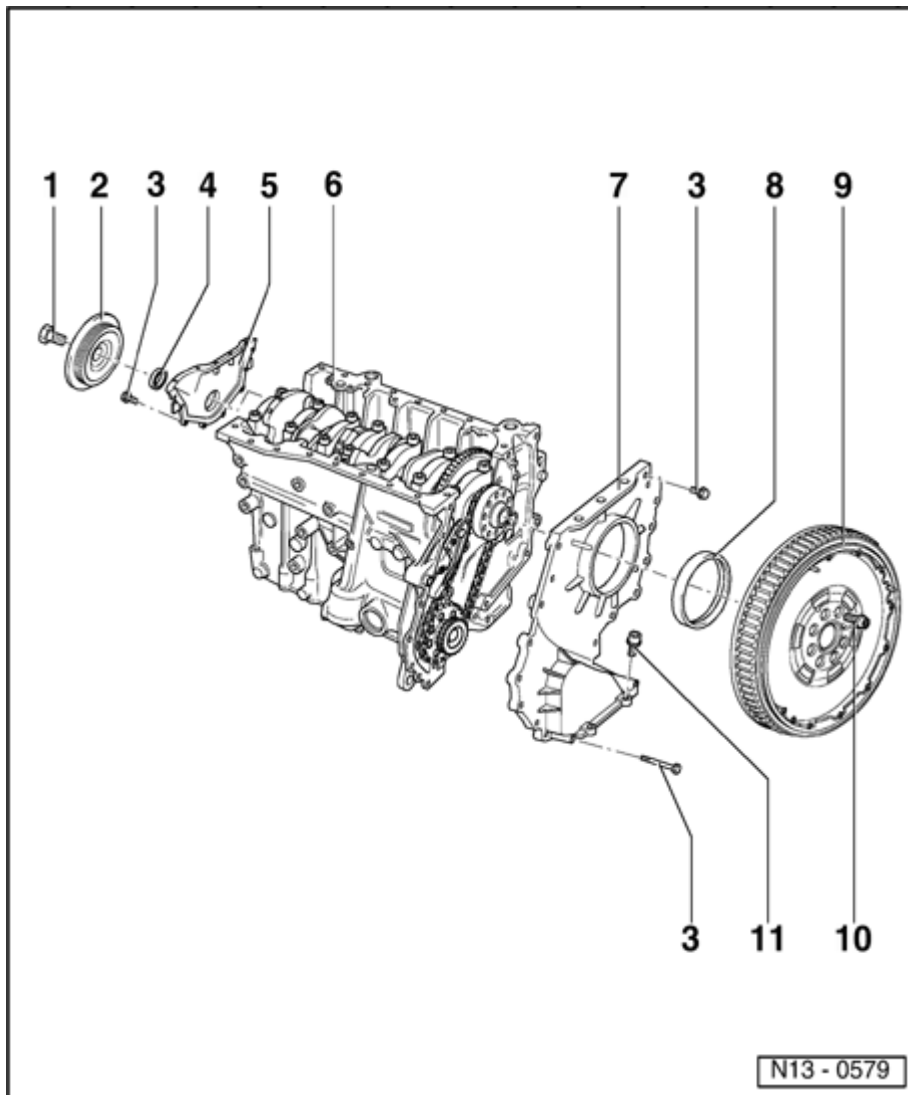

10 60 Nm
- plus
additional
1/4 turn
(90°)
further

◆ Replace

◆ Use counter support T10069 to loosen and tighten

11 - 23 Nm

13-27

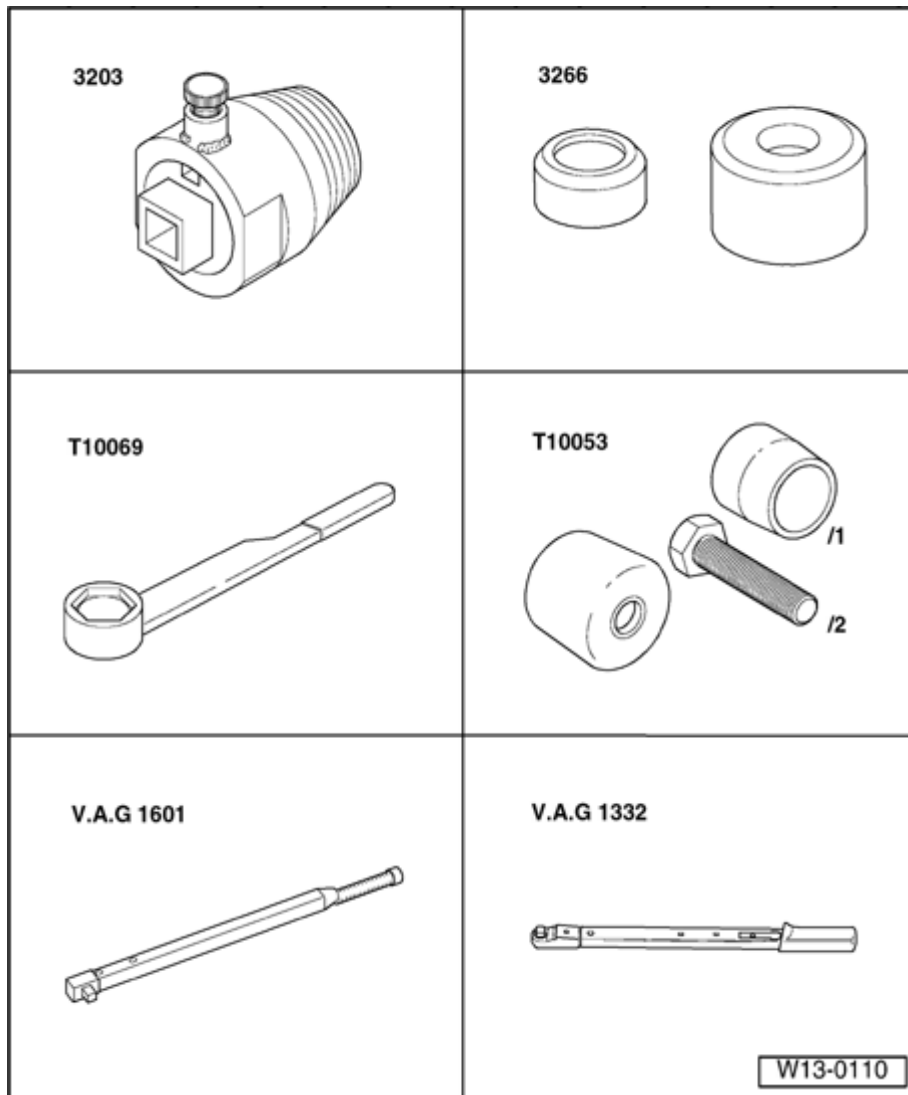

Crankshaft oil seal (vibration damper end), replacing

Special tools and equipment

- ◆ 3203 Oil seal extractor
- ◆ 3266 Sleeve
- ◆ T10069 Counter support
- ◆ T10053/1 Guide sleeve
- ◆ VAG 1601 Torque wrench (150...800 Nm)
- ◆ VAG 1332 Torque wrench (40...200 Nm)

Removing

- Remove ribbed belt ⇒ [Page 13-19](#).

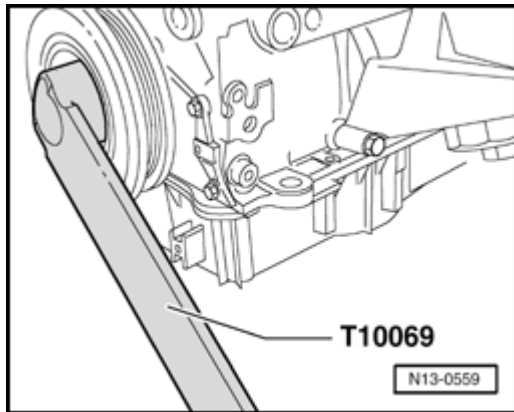

- Remove vibration damper. To do this, hold vibration damper with counter support T10069.
- Unscrew inner part of oil seal extractor 3203 three turns (approx. 4 mm) out of the outer part and lock with knurled screw.

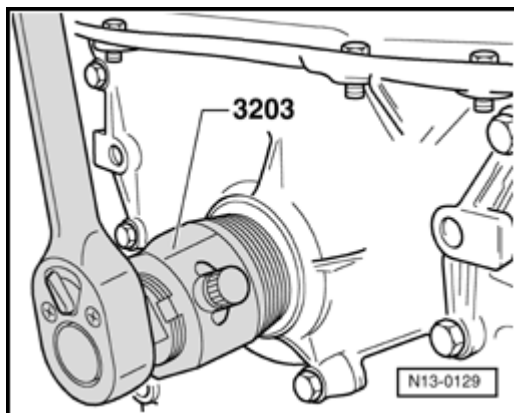

- Lubricate threaded head of oil seal extractor 3203, place it in position and exerting firm pressure screw it as far as possible into oil seal.
- Loosen knurled screw and turn inner part against crankshaft until oil seal is pulled out.

Installing

Note:

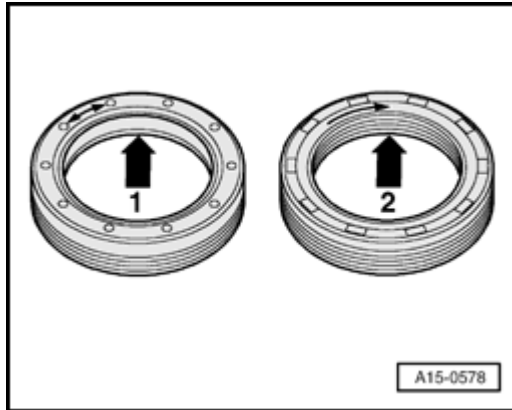

✦ *A PTFE seal (Teflon) -2- is gradually being introduced instead of the inner coil spring type seal-1-. This has a wider sealing lip. PTFE seals are fitted free of oil and grease. When a PTFE seal is installed, then only such a seal may be installed as a replacement part!*

- Before installing, remove oil remains from crankshaft journal with a clean cloth.

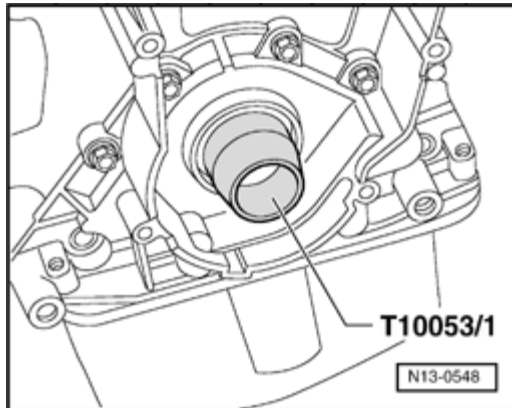

- ✦ - Install guide sleeve T10053/1 onto crankshaft journal and carefully slide seal onto guide sleeve

13-30

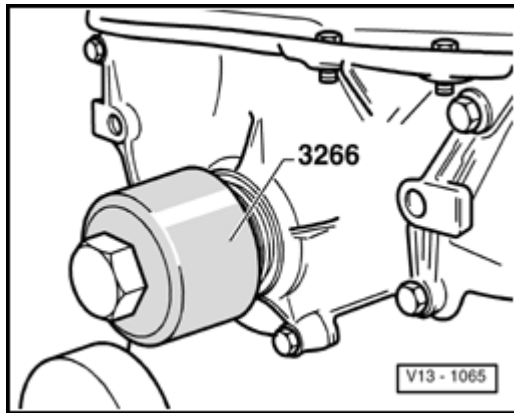

- Press seal against limit stop using press sleeve from 3266. Use old mounting bolt for vibration damper for this purpose.

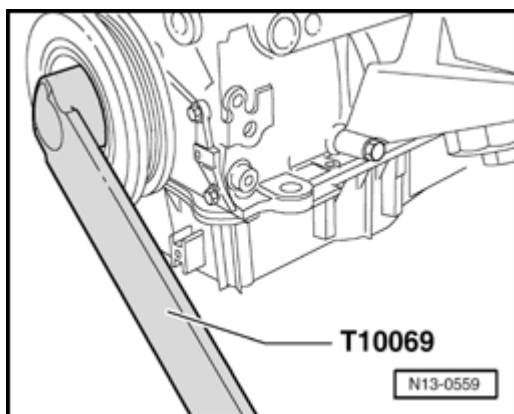

- Install vibration damper and lock it with counter support T10069.
- Tighten new bolt to 100 Nm plus additional 90° (1/4 turn - turning further can be done in several stages).

Note:

- ◆ *Vibration damper securing bolt must be replaced.*
- ◆ *Tighten securing bolt with torque wrench VAG 1601.*
- Install ribbed belt ⇒ [Page 13-19](#) .

Drive plate, removing and installing

Special tools and equipment

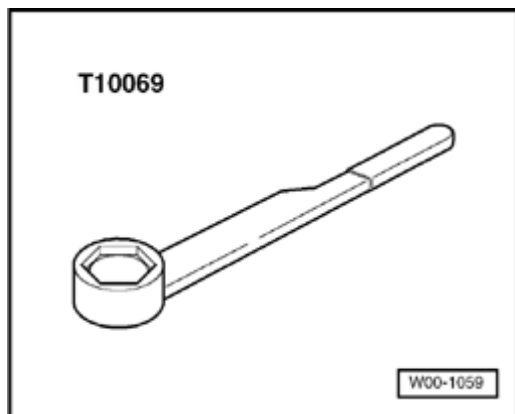

- ◆ T10069 Counter support

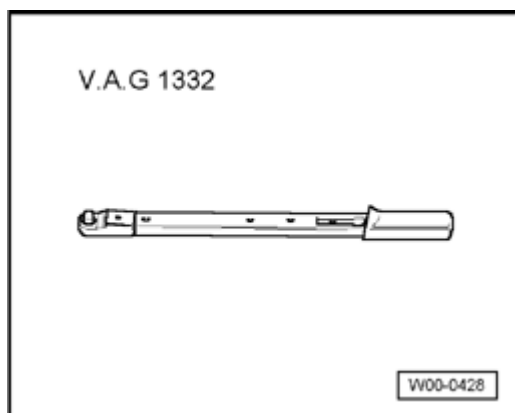

- ◆ VAG 1332 Torque wrench (40...200 Nm)
- ◆ Depth gauge
- ◆ Straight edge

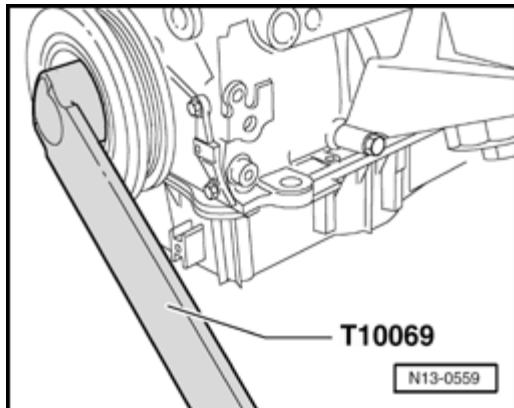

Removing

- ✦ - Remove drive plate. To do this, hold vibration damper with counter support T10069.
- Loosen drive plate securing bolts using cross-over sequence and remove them.
- Remove drive plate.

Installing

- Position drive plate on crankshaft
- Insert at least 3 old bolts and tighten to 30 Nm.

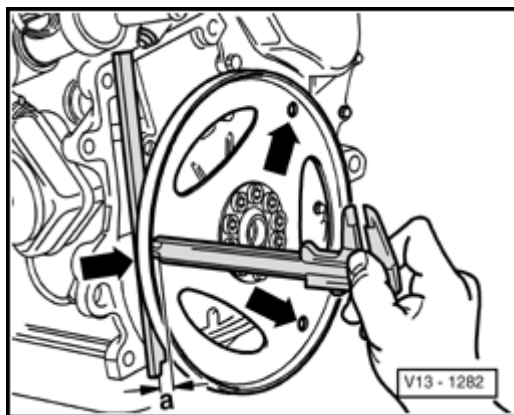

- ✦ - Check dimension -a- through three holes for securing torque converter using a straightedge and depth gauge and calculate average.
 - Compare average (measured distance + thickness of straightedge) with specification.
- Specification: 15.7...16.5 mm

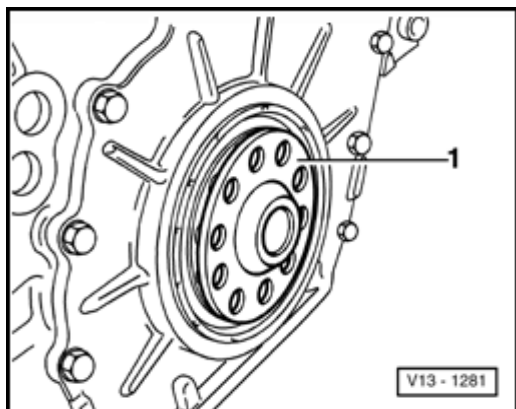

If the specification is not obtained:



- Remove drive plate again and install appropriate shim -1-

Note:

Only one shim of the appropriate thickness may be used to compensate.

If the specification is obtained:

- Install new cylinder head bolts and tighten hand tight.
- Tighten securing bolt to 60 Nm plus additional 90° (1/4 turn - turning further can be done in several stages).

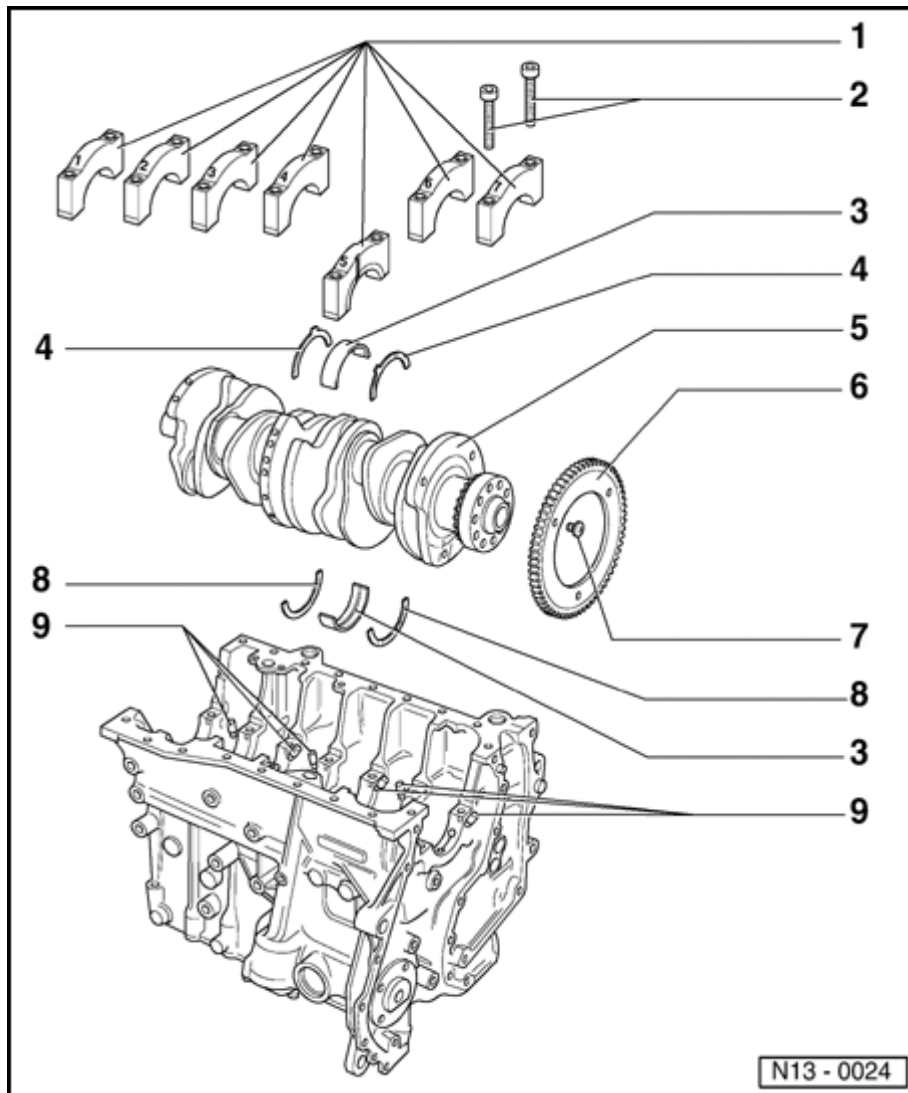

Crankshaft, removing and installing

Note:

- ◆ *When working on the engine it should be secured to assembly stand VW 313 using engine bracket 3269 or VW 540 and supplementary set 540/1 B.*
- ◆ *Before removing the crankshaft, ensure that a suitable place has been prepared to ensure that the sensor wheel (item - 6 -) does not make contact or become damaged.*
- ◆ *When changing bearing shells ensure that bearing shells of same color code are used.*

1 - Bearing cap

- ◆ Bearing cap 1: Vibration damper end

- ◆ Bearing cap 5 with recesses for thrust washers
- ◆ Bearing shell retaining lugs (cylinder block/bearing cap) must be on the same side

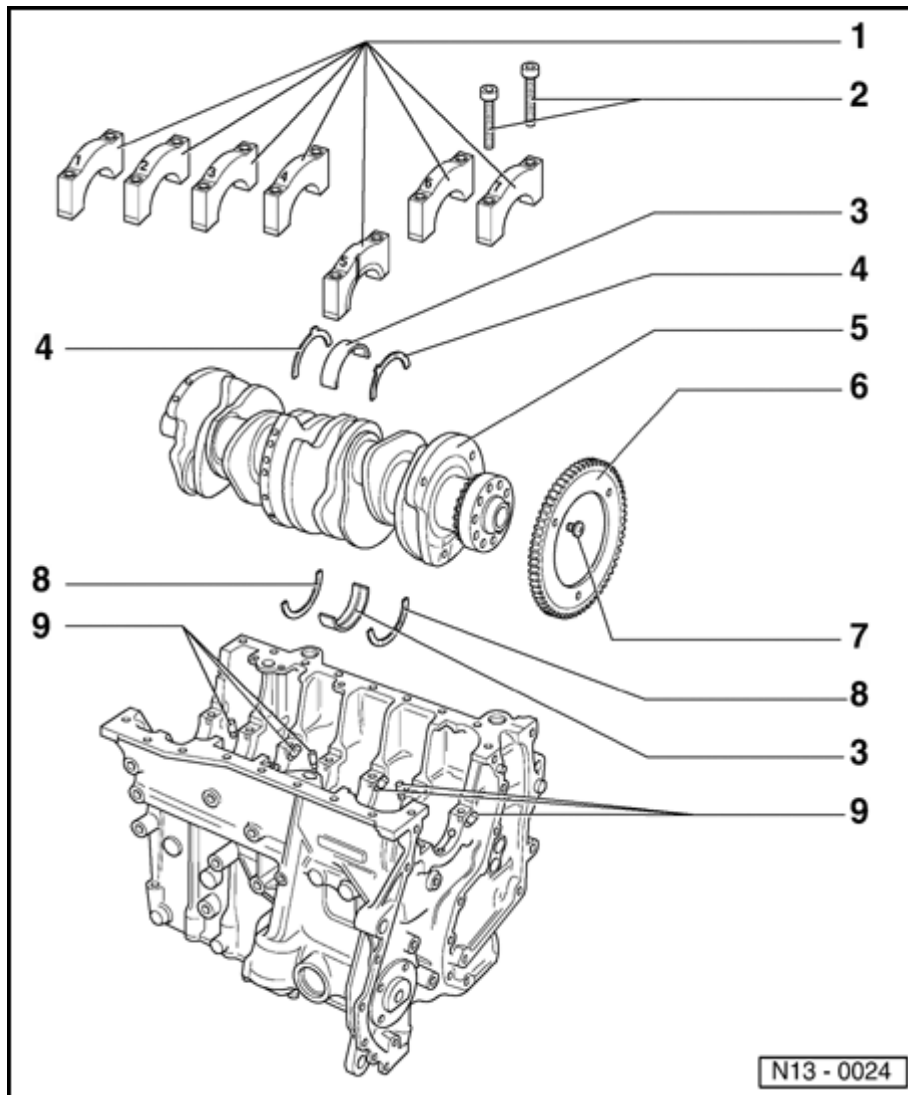

**2 - 30 Nm
plus
additional
 $\frac{1}{2}$ turn
(180°)
further**

◆ Replace

◆ Turning $2 \times 90^\circ$
further is
permitted

**3 - Bearing
shells
1...7**

◆ Observe
note
before
removing
⇒ [Page
13-34](#)

◆ For
bearing
cap
without
oil
groove

◆ For
cylinder
block
with oil
groove

◆ Do not
interchange
used
bearing
shells
(mark
location)

**4 - Thrust
bearing**

◆ For
bearing
cap 5

- ◆ Check locating point

13-36

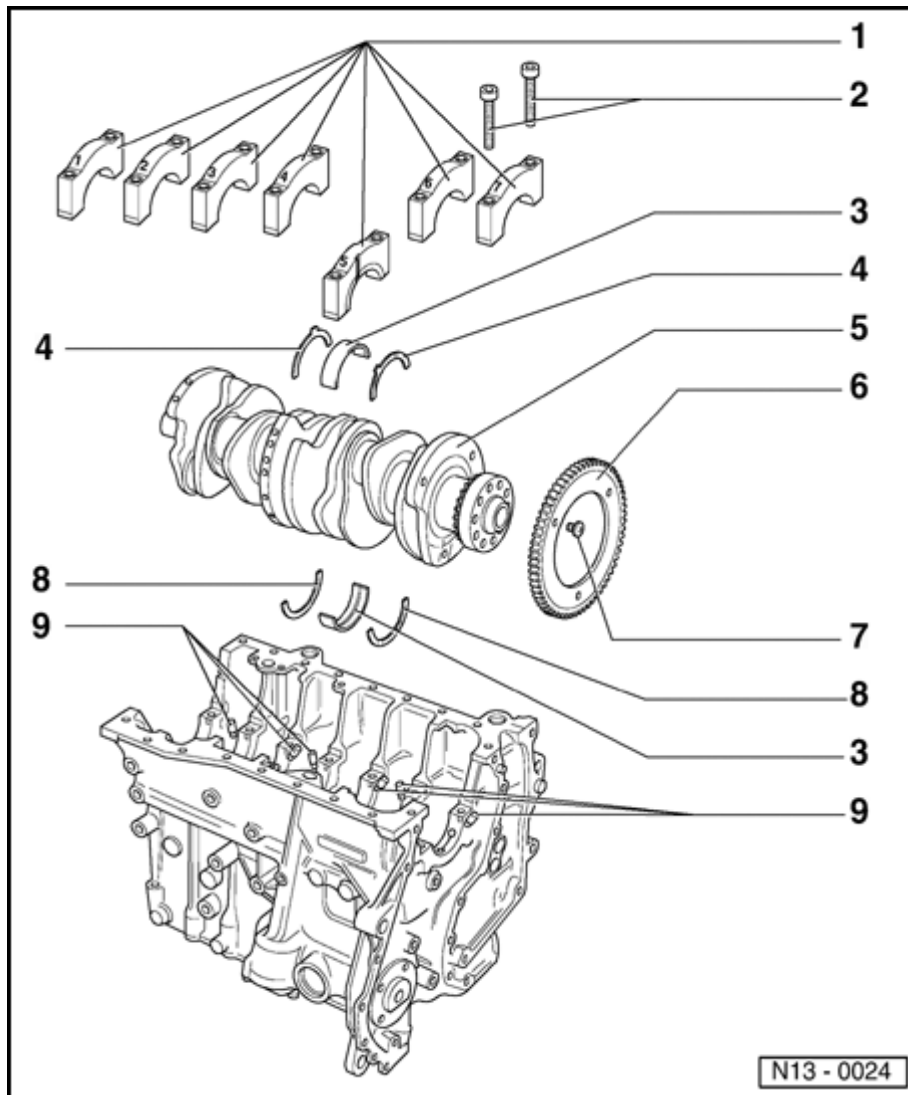

5 - Crankshaft

- ◆ Observe note before removing ⇒ [Page 13-34](#)
- ◆ Axial clearance new: 0.07...0.24 mm, Wear limit: 0.30 mm
- ◆ Check radial clearance with Plastigage, New: 0.02...0.06 mm, Wear limit: 0.10 mm
- ◆ Do not turn crankshaft when checking the radial clearance
- ◆ Crankshaft dimensions:
Main bearing: 59.958...59.978 mm
Conrod bearing: 53.958...53.978 mm

6 - Sensor wheel

- ◆ For Engine speed (RPM)

sensor -
G28-

◆ Replace

◆ Installing
⇒ [Fig. 1](#)

13-37

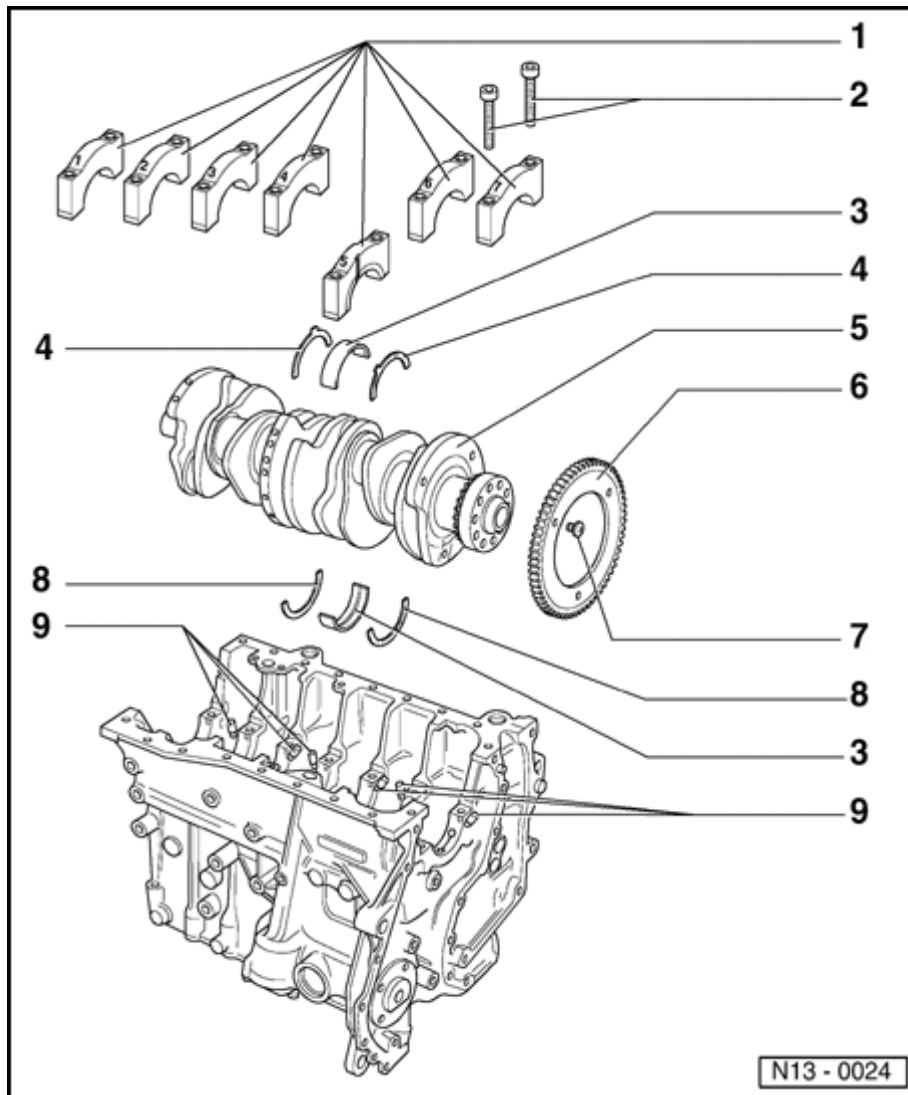

**7 - 10 Nm
plus
additional
 $\frac{1}{4}$ turn
(90°)
further**

◆ Replace

◆ Observe
sequence
when
tightening
⇒ [Fig. 1](#)

**8 - Thrust
bearing**

◆ For
bearing
cap 5

◆ Check
locating
point

**9 - Oil
spray
jet**

◆ For
crankshaft
bearings
2...7

◆ For
piston
cooling

◆ Opening
pressure:
2.0 bar

◆ Removing
and
installing
⇒ [Page
17-7](#) , Fig.
1

◆ See
note
⇒

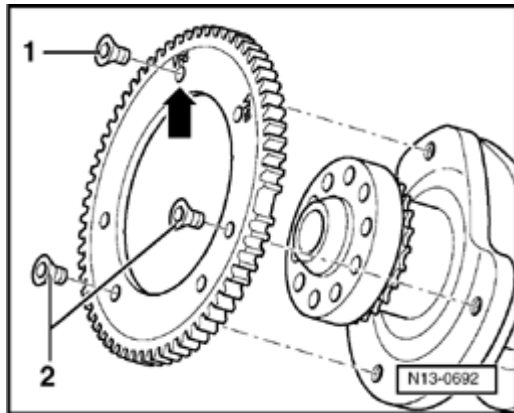

Fig. 1 Installing sensor wheel to crankshaft

Special tools and equipment

- ◆ VAG 1331 Torque wrench (5...50 Nm)
- ◆ D 000 600 A2 Locking compound

Work sequence

Make sure crankshaft/sensor wheel contact surfaces are free of oil and grease.

- Apply a thin coat of locking compound D 000 600 A2 to contact surfaces of crankshaft and sensor wheel for additional security.
- Check that when installing "VR6" (arrow) is marked at individual threaded holes.
- Tighten all new securing bolts lightly by hand.
- Tighten securing bolt -1- to 10 Nm plus additional 90° (1/4 turn).
- Tighten securing bolts -2- to 10 Nm plus additional 90° (1/4 turn).

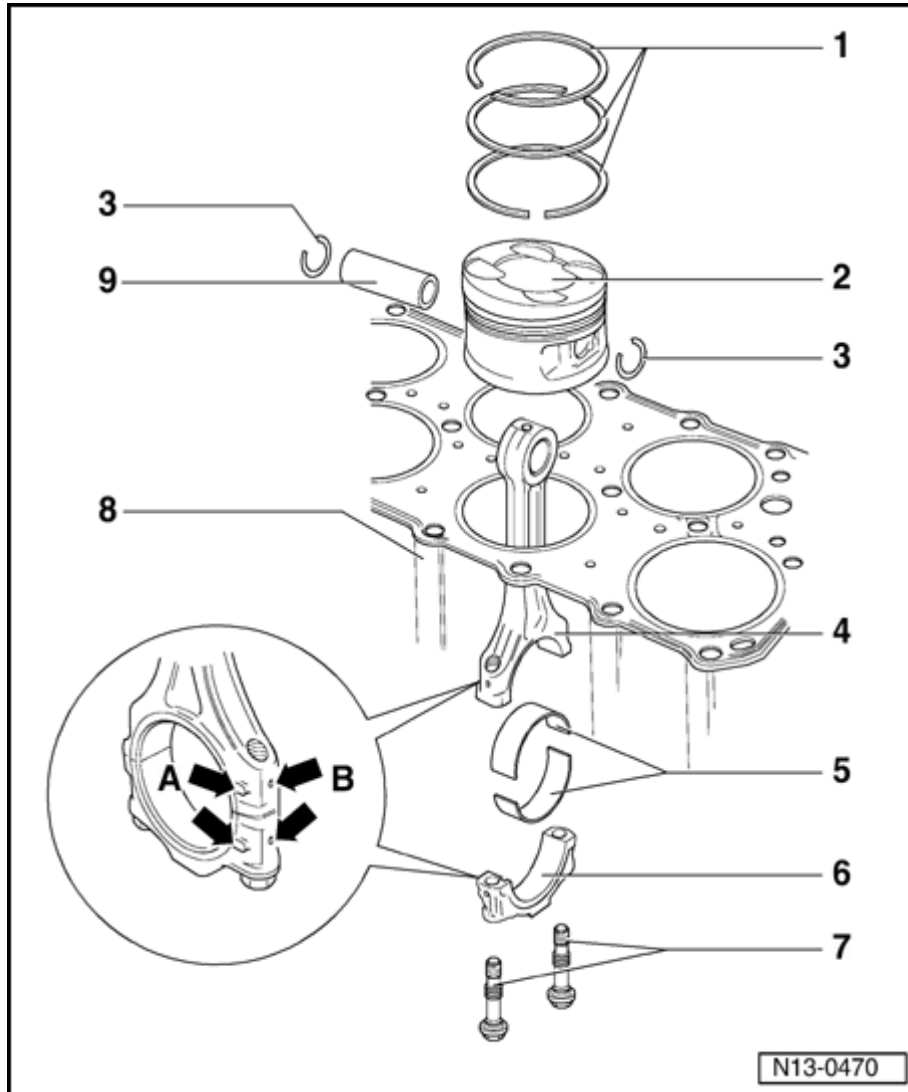

Piston and connecting rod, disassembling and assembling

1 - Piston rings

- ◆ Offset gaps 120°
- ◆ Use piston ring pliers to remove and install
- ◆ "TOP" face towards piston crown
- ◆ Checking ring gap \Rightarrow [Fig. 1](#)
- ◆ Checking ring to groove clearance : [Fig. 2](#)

2 - Piston

- ◆ Checking = [Fig. 3](#)
- ◆ Mark installation position to connecting rod and cylinder
- ◆ Flatter side piston crown faces towards center of cylinder block
- ◆ Install with piston installation (funnel) 32° \Rightarrow [Fig. 5](#)

3 - Snap ring

13-40

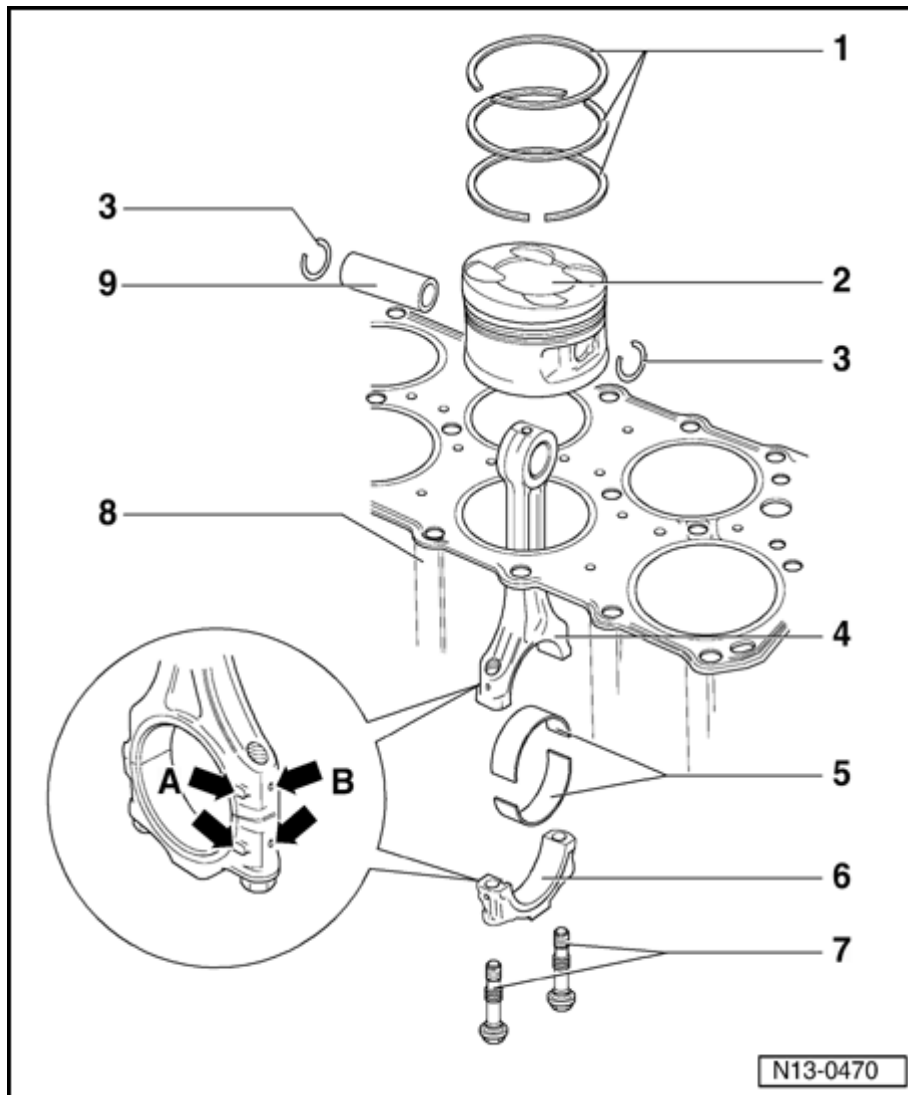

4 - Conrod

- ◆ Only replace as a set
- ◆ Mark position to cylinder -B-
- ◆ Installation position: Marks -A- must be aligned above one another

5 - Bearing shell

- ◆ Observe installation position
- ◆ Do not interchange used bearing shells
- ◆ Lugs on bearing shells must fit tightly in recesses
- ◆ Axial clearance, New: 0.05...0.35 mm, Wear limit: 0.40 mm
- ◆ Check radial clearance with

Plastigage:
New:
0.02...0.07
mm, Wear
limit: 0.10
mm. Do
not turn
crankshaft
when
checking
radial
clearance

13-41

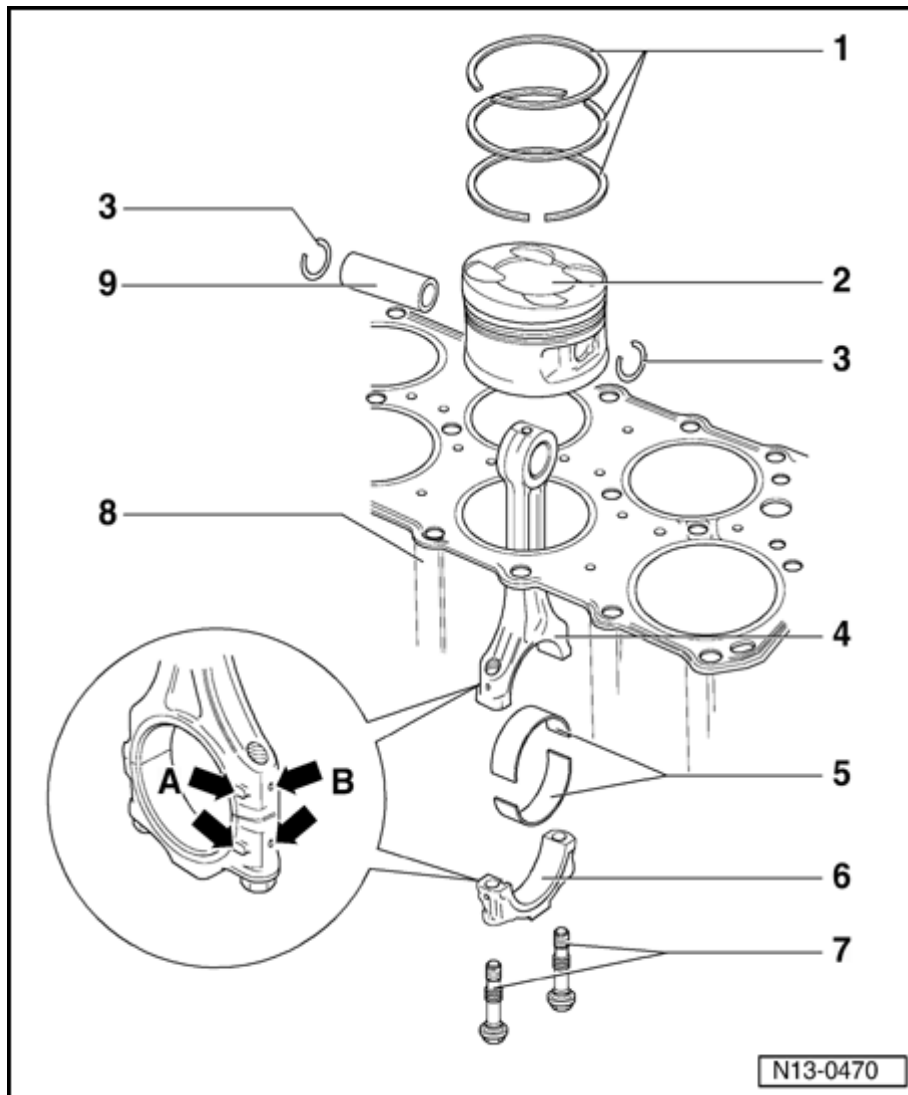

6 - Conrod bearing cap

- ◆ Mark position to cylinder -B-
- ◆ Installation position: Marks -A- must be aligned above one another
- 7 - 30 Nm plus additional $\frac{1}{4}$ turn (90°) further**
- ◆ Replace
- ◆ Oil thread and contact surface

- ◆ To measure radial clearance tighten to 30 Nm, but do not turn further

8 - Cylinder block

- ◆ Checking cylinder bore \Rightarrow [Fig. 4](#)
- ◆ Removing and

installing
crankshaft
⇒ [Page
13-34](#)

◆ Piston and
cylinder
dimensions
⇒ [Page
13-48](#)

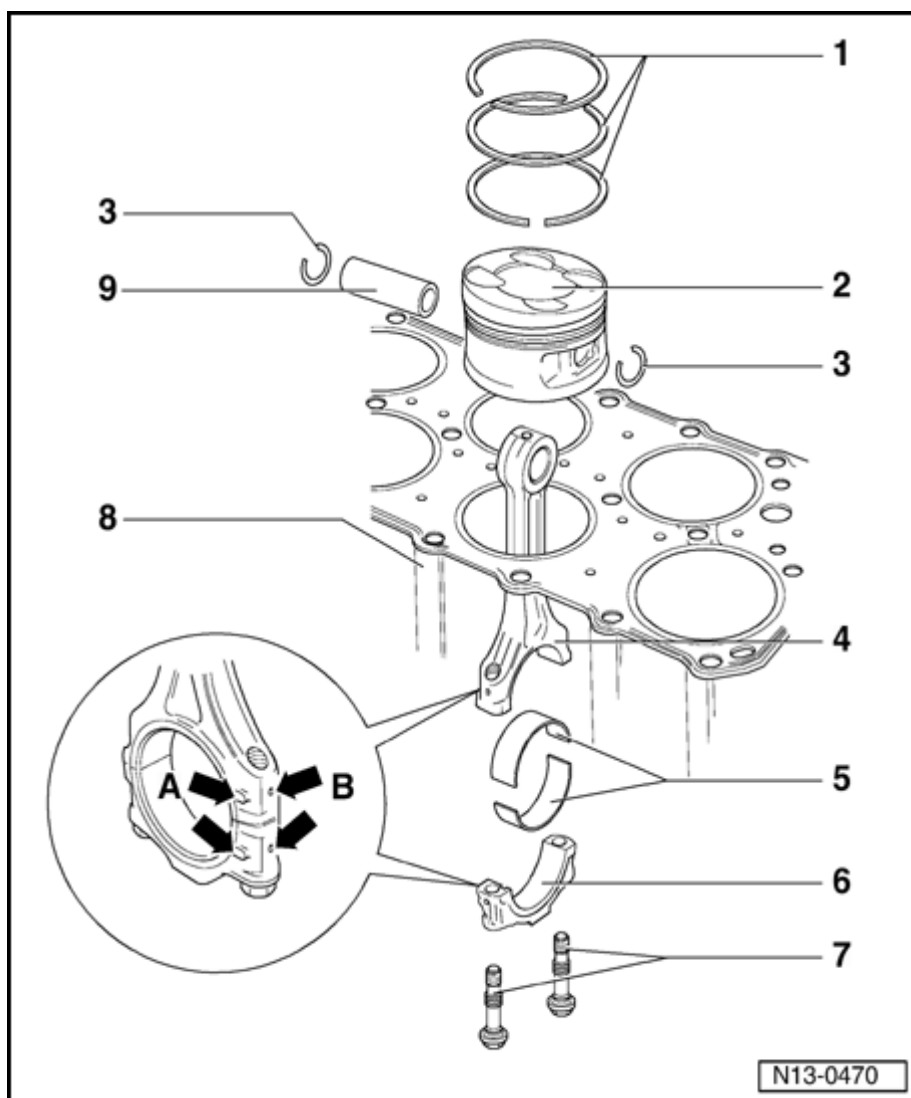

9 - Piston pin

◆ If difficult to remove, heat piston to 60 °C

◆ Remove and install with drift VW 222a

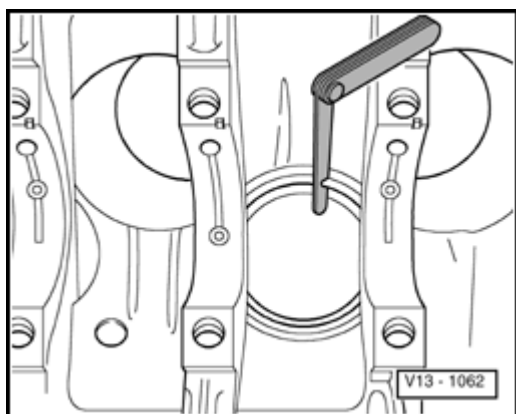

Fig. 1 Checking piston ring gap

Special tools and equipment

- ◆ Feeler gauge

Test sequence

- Push ring squarely from above down to approx. 15 mm from bottom end of cylinder. To do this use a piston without rings.

| Piston ring | | Gap | |
|----------------------|----|-------------|------------|
| | | New | Wear limit |
| Compression ring | mm | 0.20...0.40 | 1.0 |
| Tapered-stepped ring | mm | 0.20...0.40 | 1.0 |
| Oil scraper ring | mm | 0.25...0.50 | 1.0 |

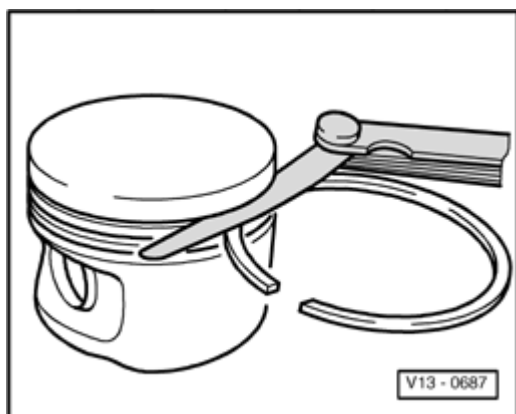

Fig. 2 Checking ring to groove clearance

Special tools and equipment

- ◆ Feeler gauge

Test sequence

- Clean ring groove before checking.

| Piston ring | | Ring to groove clearance | |
|----------------------|----|--------------------------|------------|
| | | New | Wear limit |
| Compression ring | mm | 0.04...0.08 | 0.15 |
| Tapered-stepped ring | mm | 0.02...0.06 | 0.15 |
| Oil scraper ring | mm | 0.03...0.06 | 0.15 |

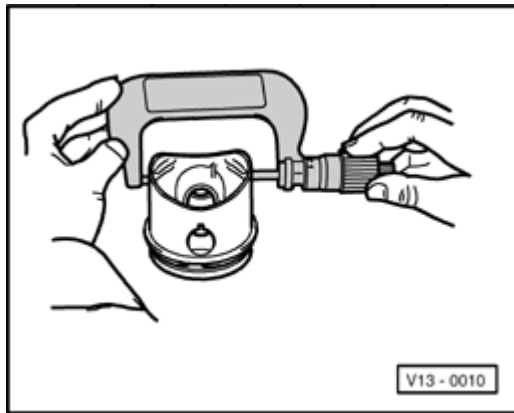

Fig. 3 Checking piston

Special tools and equipment

- ◆ External micrometer 75...100 mm

Test sequence

- Take measurement approx. 6 mm from lower edge of piston skirt and offset 90 ° to piston axis.

Deviation from nominal dimension: max. 0.04 mm

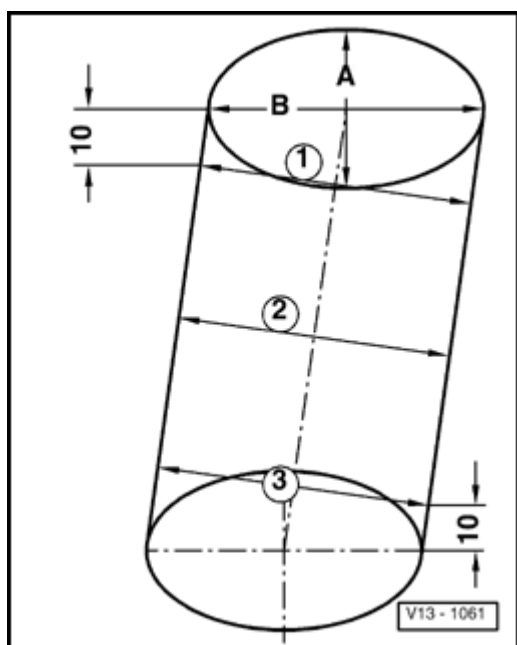

Fig. 4 Checking cylinder bores

Special tools and equipment

- ◆ Internal dial gauge 50...100 mm

Test sequence

- Measure bores at 3 locations in both directions -A- across engine and -B- in line with crankshaft.

Deviation from nominal dimension: max. 0.08 mm

Note:

The cylinder bores must not be measured if the cylinder block is mounted on a repair stand with engine bracket 3269 or VW 540, as incorrect measurements would then result.

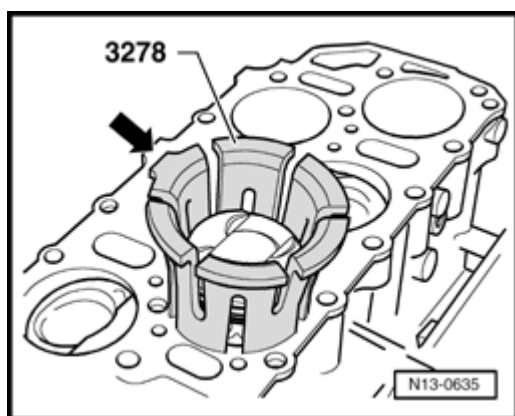

Fig. 5 Installing pistons with piston installation tool (funnel) 3278

Special tools and equipment

- ◆ 3278 Funnel

Note:

If a new installation tool (funnel) is used to install the pistons, first pass piston with oiled piston rings through the funnel twice and remove the resulting metal shavings if necessary. Only then install piston with piston rings.

Work sequence

- Push piston by hand into oiled installation tool (funnel). Flat side of piston crown must face toward tab on funnel (arrow).
- Hold installation tool (funnel) on upper edge and press piston in with both thumbs.
- Push piston in until it protrudes approx. 15 mm from lower edge of tool (funnel).
- Insert piston into appropriate cylinder bore. Tab on tool (arrow) must face center of cylinder block.
- Press installation tool (funnel) tightly against cylinder block and push piston in.

Piston and cylinder dimensions

| Honing dimension | | Piston diameter | Cylinder bore diameter |
|-------------------------|----|------------------------|-------------------------------|
| Basic dimension | mm | 80.965 | 81.010 |
| 1st oversize | mm | 81.465 | 81.510 |
| 2nd oversize | mm | 81.965 | 82.010 |