

# Self-diagnosis

## The readiness code

The readiness code is an 8-digit numeric code which indicates the status of the exhaust emission diagnoses. The diagnoses are performed at regular intervals during normal vehicle operation.

The readiness code does **not** indicate whether there are any faults in the system. It indicates whether certain diagnosis have been terminated -0- or have not been performed yet, or have been cancelled -1-.

If the engine management system has registered a fault and stored this fault in the fault memory, the fault message can only be obtained with a fault reader.

The readiness code can be read out using the Vehicle Diagnostic, Testing and Information System VAS 5051 or the V.A.G Diagnostic Unit using function "15" which can be accessed via address word "01". The readiness code can also be generated by performing a short test.

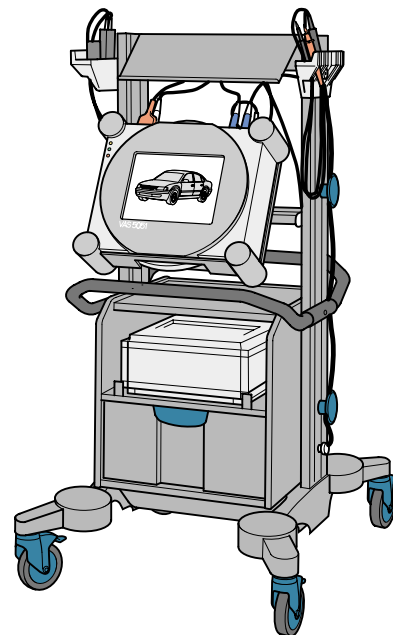

202\_002



### Readiness code

The readiness code for both engines is identical.

### Relevance of the 8-digit numeric block to the readiness code

The readiness code is only generated when all the digit positions on the display are 0.

1	2	3	4	5	6	7	8	Diagnostic function
							0	Catalytic converter
						0		Catalytic converter heating (diagnosis function currently inactive/always "0")
					0			Activated charcoal canister system (fuel tank purging system)
				0				Secondary air system
			0					Air conditioning system (diagnosis function currently inactive/always "0")
		0						Lambda probe
	0							Lambda probe heater (diagnosis function currently inactive/always "0")
0								Exhaust gas recirculation (not existent/always "0")

The Motronic 5.9.2 control unit has a fault memory.

The self-diagnosis function monitors all the colour-coded parts of the system.

The self-diagnosis procedure can be performed using the Vehicle Diagnostic, Testing and Information System VAS 5051 or the V.A.G Diagnostic Unit.

The self-diagnosis procedure is initiated with the address word  
01 - Engine electronics.

The following functions are possible:

- 01 - Interrogate control unit version
- 02 - Interrogate fault memory
- 03 - Actuator diagnosis
- 04 - Basic adjustment
- 05 - Erase fault memory
- 06 - End of output
- 07 - Encode control unit
- 08 - Read data block
- 10 - Adaption
- 11 - Login procedure
- 15 - Read out readiness code



Function 04 - Basic adjustment must be executed after changing the engine control unit, the throttle valve control part or the engine and after disconnecting the battery.

Advise your customers to visit a workshop to have basic adjustment performed after replacing the battery themselves or after disconnecting and connecting the battery.

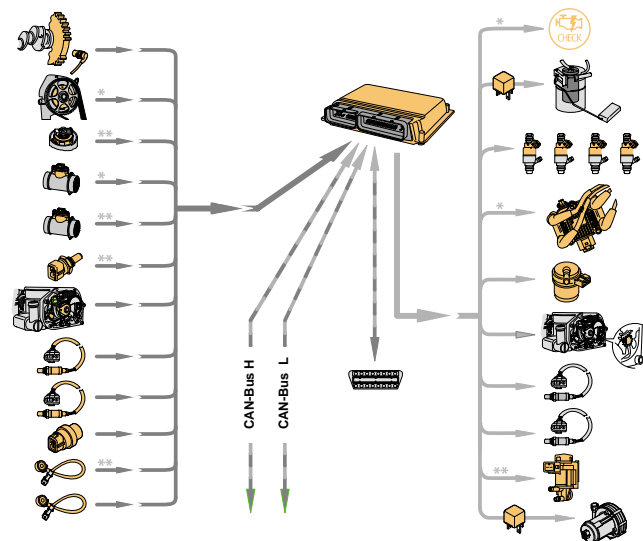

233\_018

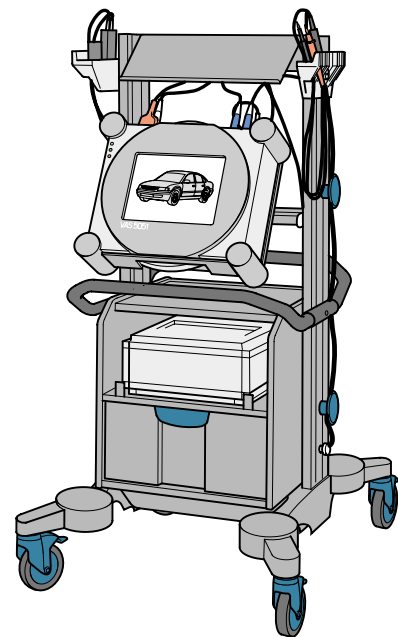

202\_002



For the various individual fault codes, please refer to the Workshop Manual for Motronic Injection and Ignition System (2.0-litre engine).

# 2.0-litre/88 kW engine ATF/ASU

The 2.0-litre/88 kW Flino engine is described below. Flino stands for "flying camshaft". The engine will be used in A-platform vehicles, in which it will be mounted transversely, and in the Passat, in which it will be mounted longitudinally.

The improved version of the 2.0-litre engine includes the following characteristic modifications:

- Adjustment of the intake cam
- The system components for service interval extension (new engine oil, engine oil level sensor and engine oil temperature sensor)
- Twin-path intake manifold
- Electric throttle drive

The engine-specific requirements relating to service interval extension and camshaft timing control are described.



233\_012

## Technical features

- Engine management system  
Transversely mounted engine: Bosch Motronic ME 7.5  
Longitudinally mounted engine: Simos 3.2
- Electronically controlled sequential injection and mapped ignition with cylinder-selective knock control
- 2 valves per cylinder
- 2 lambda probes; Syncro: 4 lambda probes
- Secondary air system
- Air-shrouded injectors
- Twin-path intake manifold
- Electrical throttle control
- Exhaust gas monitoring (OBD II)
- EU IV compliant

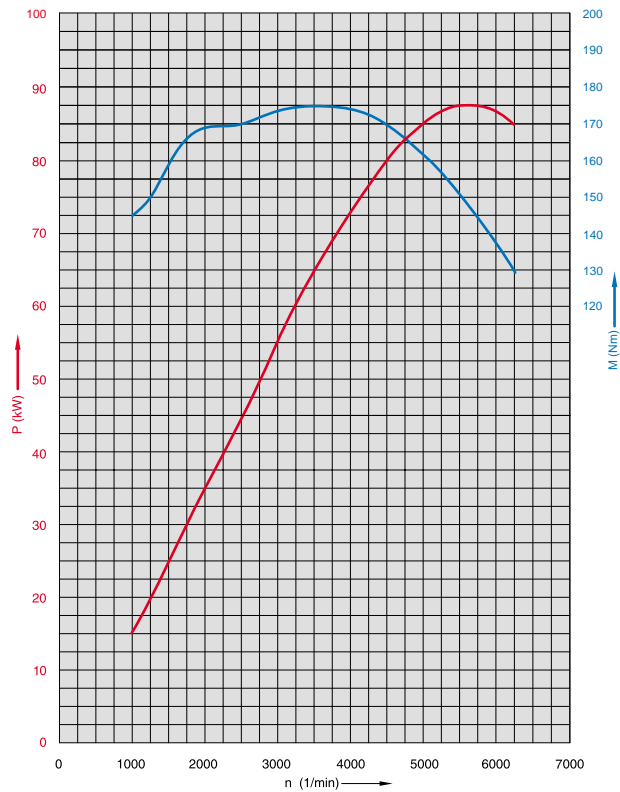

233\_021

## Specifications

Code:ATF (transversely mounted),  
 A-platform  
 ASU (longitudinally mounted)  
 Passat

Type:4-cylinder in-line engine

Displacement:1984 cm<sup>3</sup>

Bore:82.5 mm

Stroke:92.8 mm

Compression

ratio:10 : 1

Firing order:1 - 3 - 4 - 2

Rated output:88 kW (120 bhp)

Torque:175 Nm

Fuel:RON 95 unleaded

RON 91 unleaded

(reduced power and torque)



# Overhung-mounted camshaft

## Camshaft timing control

The camshaft timing control operates mechanically with the intake cam overhung mounted.

This camshaft – code designation Flino – allows rpm-dependent intake closure.

### Advantages:

Better torque delivery across the entire rev band, higher fuel economy and improved elasticity.

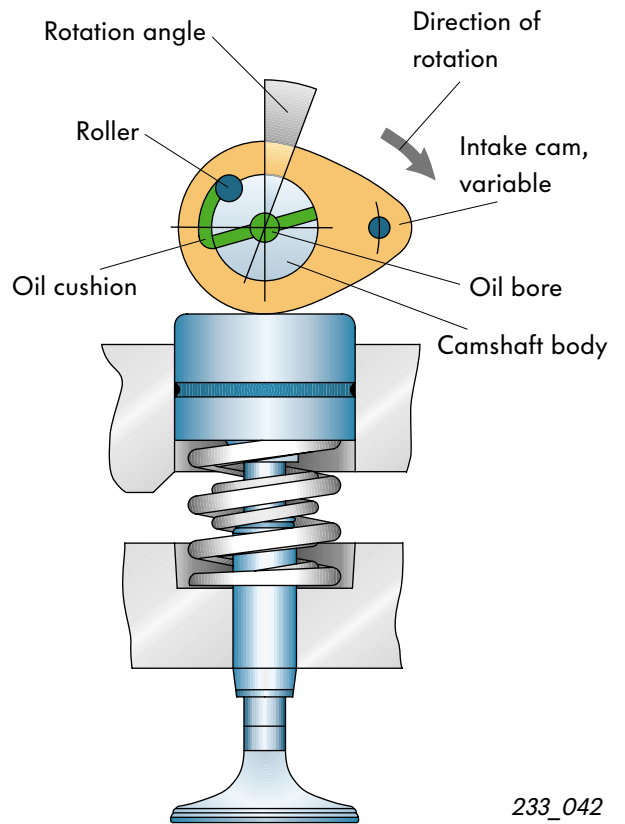

233\_042

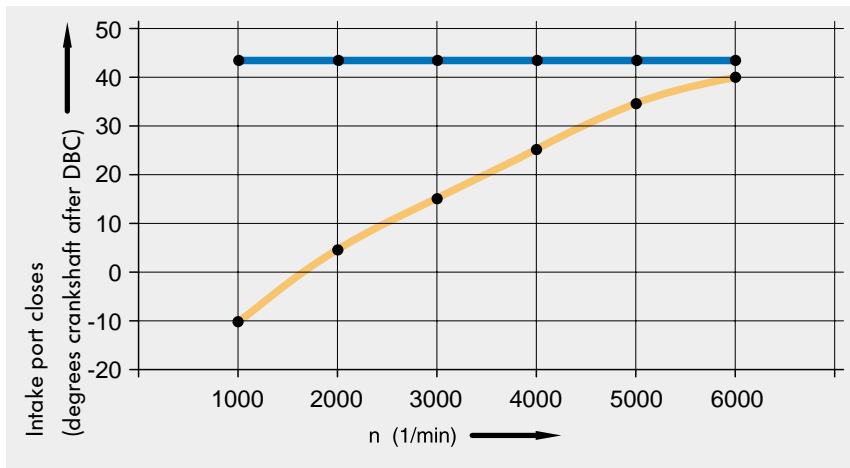

— Rigid camshaft  
— Variable camshaft

233\_043

Intake port - closing - position in dependence on engine speed

## Function

The opening action at the intake valve is no different to that on a rigid camshaft. During the closing action, however, the cam becomes twisted under the spring pressure exerted by the valve spring.

The rotation angle of the intake cam is dependent on engine speed. At low engine speeds, the rotation angle is greater than at high engine speeds.



Please refer to SSP 229 for more detailed information.

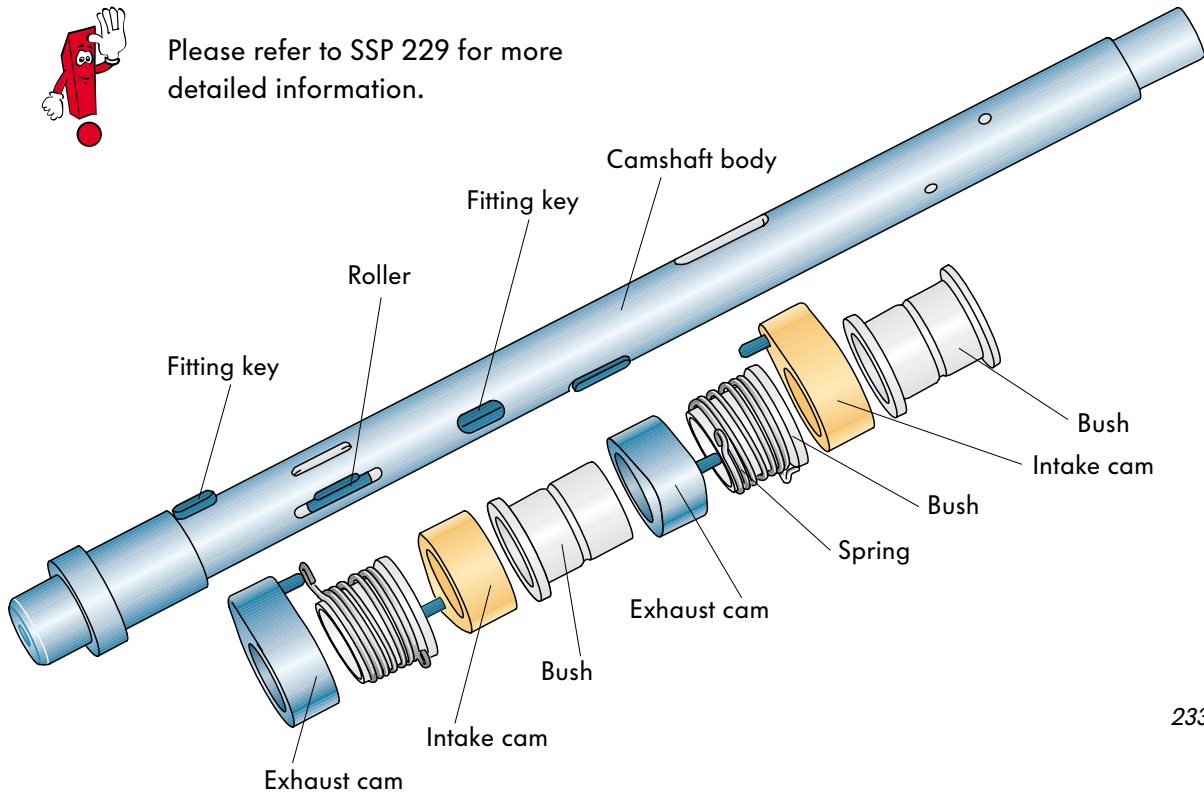

233\_044

Function	85 kW engine	88 kW engine
<b>Camshaft</b>	The shaft, intake cam and exhaust cam are a single part	A camshaft body with one oil bore aligned longitudinally and transversely in relation to the intake cam. Exhaust cam with fitting key securely connected to the body. Intake cam mounted rotatably on body. An inserted roller drives the cam and limits the angle of rotation. Oil pressure is applied to the empty space in the cam above the camshaft body. The oil cushion dampens the rotary motion and absorbs noise.
<b>Adjustment</b>	none	The intake cam is turned depending on engine speed. It rotates under the force exerted by the valve spring in the direction of rotation of the camshaft, but more quickly than the camshaft itself rotates. The cam "flies" ahead of the camshaft.
<b>Timing</b>	The exhaust port and intake valve have fixed timings	The exhaust valve has a fixed timing The intake valve has a fixed timing for the start of the opening movement and a variable timing for the end of the opening movement.



# System overview - ATF/ASU

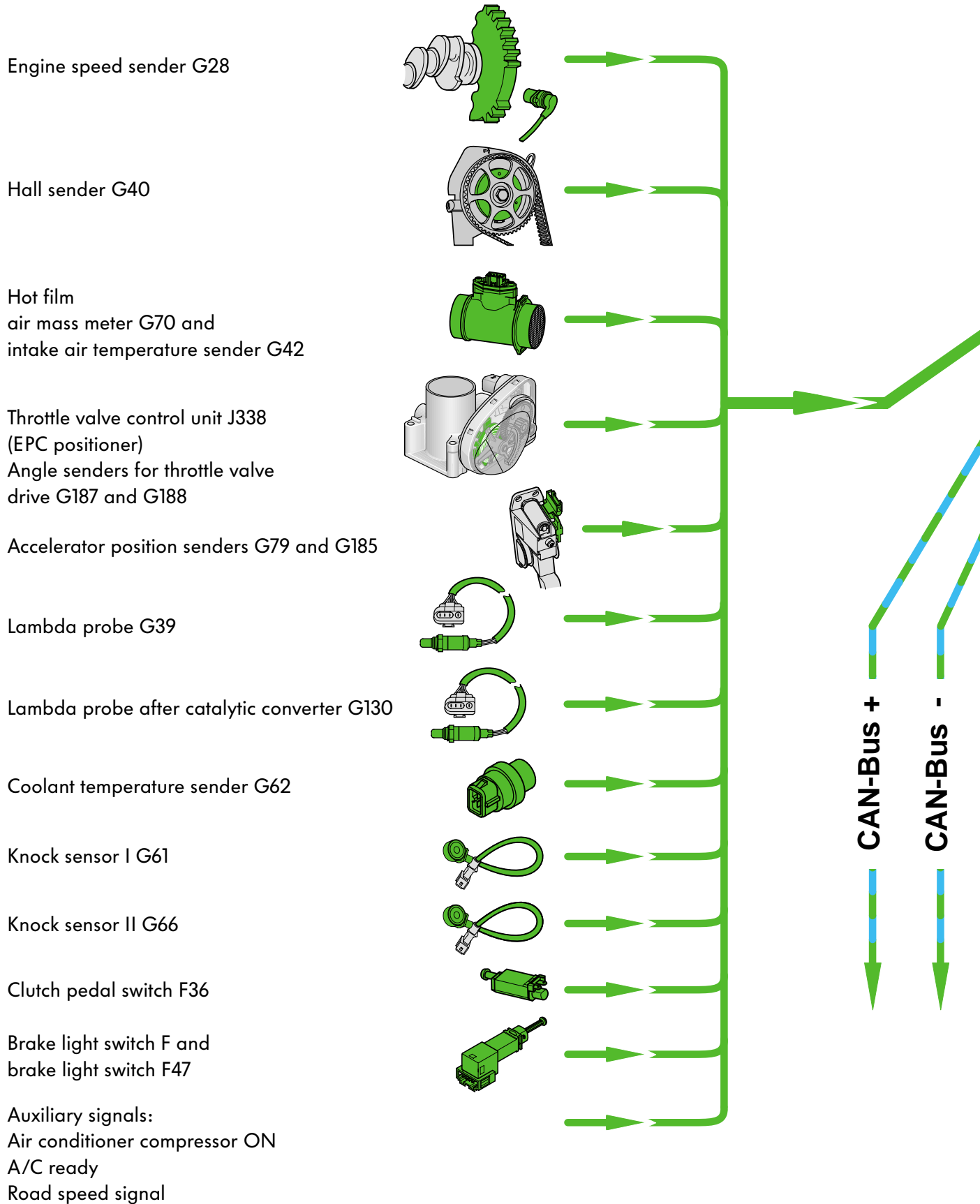

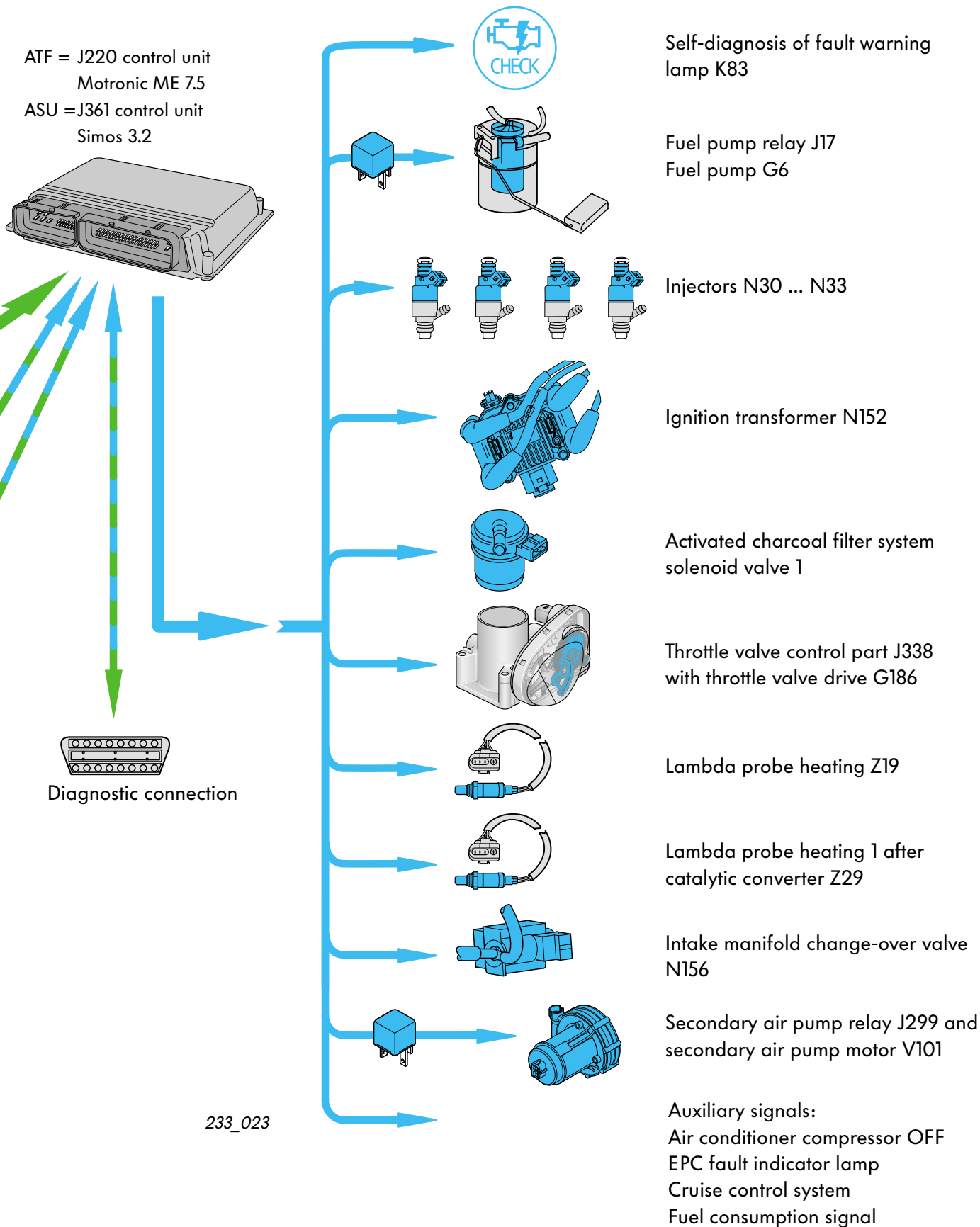

233\_023

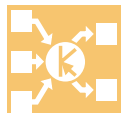

# Function diagram - ATF/ASU

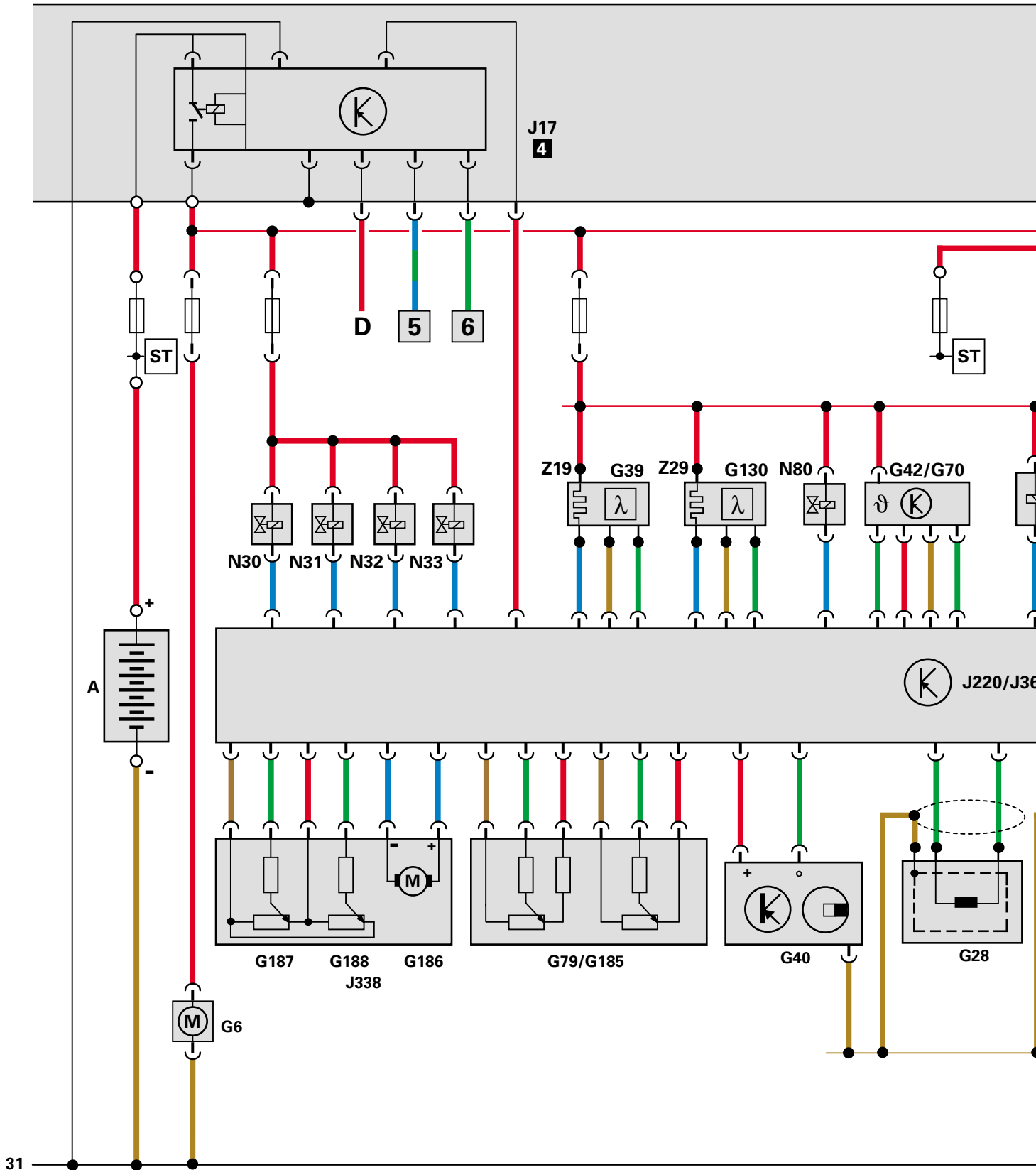

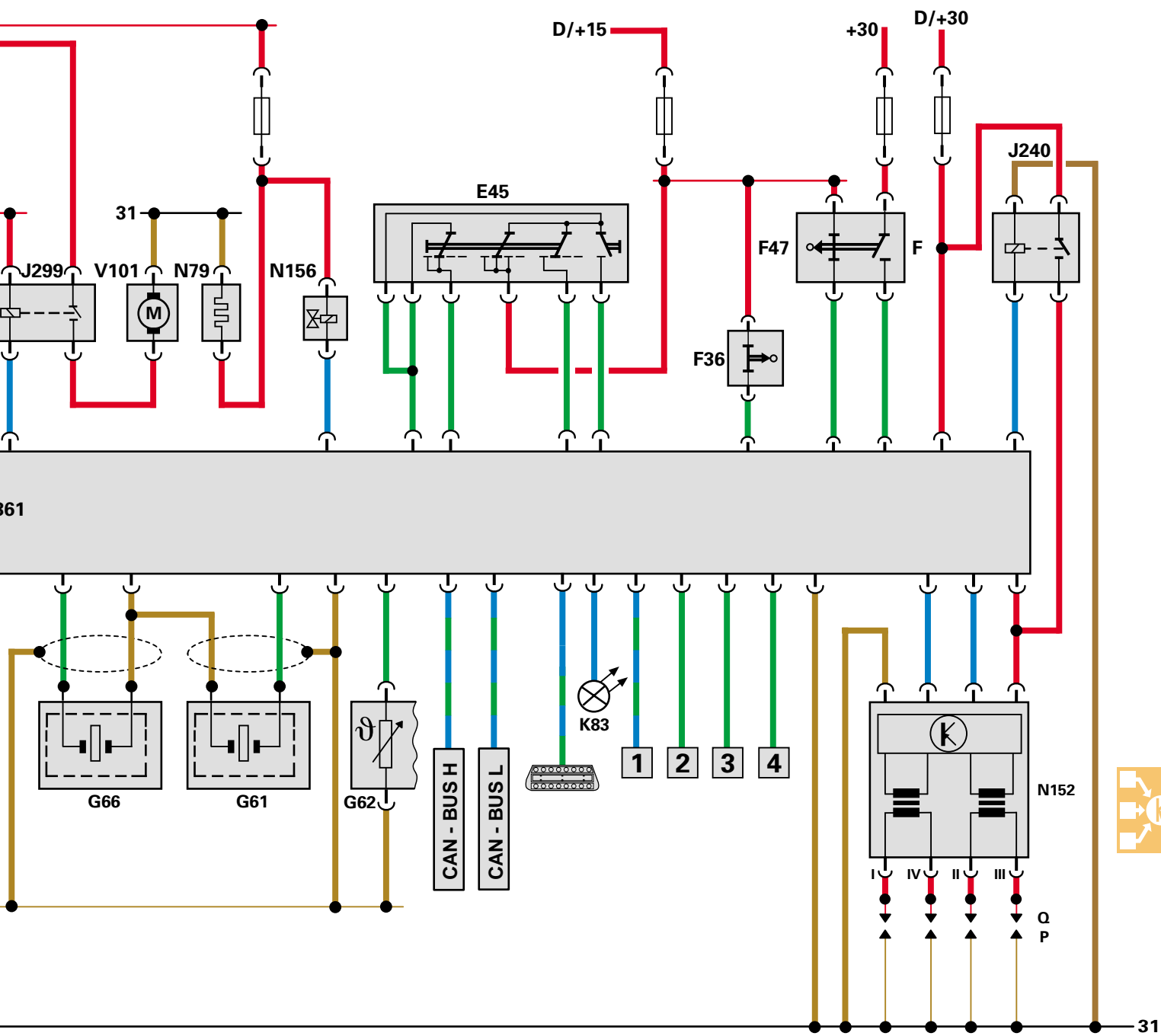

## Legend for Function Diagrams

The Function Diagram represents a simplified current flow diagram.

It contains information on the links between the Motronic 5.9.2 engine management system for the 2.0 l/85 kW (code AQY or ATU) and 2.0 l/88 kW (code ATF or ASU) engines and the Motronic ME 7.5 or Simos 3.2 engine management system.

### Auxiliary signals

- 1 Air conditioner compressor On/Off
- 2 A/C ready (in)
- 3 Road speed signal
- 4 Fuel consumption signal
- 5 Rotary latch switch, driver's door
- 6 Airbag

### Colour codes/Legend

 = Input signal

 = Output signal

 = Battery positive

 = GND

 = Bidirectional

 = Diagnostic connection

### Parts

- A Battery
- D Ignition switch
- E45 CCS switch
- F Brake light switch
- F36 Clutch pedal switch
- F47 Brake pedal switch for CCS
- F60 Idling speed switch

- G6 Fuel pump
- G28 Engine speed sender
- G39 Lambda probe (upstream of catalytic converter)
- G40 Hall sender
- G42 Intake air temperature sender
- G61 Knock sensor I
- G62 Coolant temperature sender
- G66 Knock sensor II
- G69 Throttle valve potentiometer
- G70 Air-mass flow meter
- G72 Intake manifold temperature sender
- G79 Accelerator pedal position sender
- G88 Throttle valve positioner Potentiometer
- G108 Lambda probe II
- G130 Lambda probe (downstream of catalytic converter)
- G185 Accelerator pedal position sender -2-
- G186 Throttle valve drive (electric throttle operation)
- G187 Throttle valve drive angle sender -1-
- G188 Throttle valve drive angle sender -2-
- J17 Fuel pump relay
- J220 Motronic control unit
- J299 Secondary air pump relay
- J338 Throttle valve control unit
- J361 Simos control unit
- K83 Self-diagnosis fault warning lamp
- N30...33 Injectors
- N79 Heating resistor (crankcase breather)
- N80 Activated charcoal filter system solenoid valve 1
- N112 Secondary air inlet valve
- N122 Output stage
- N152 Ignition transformer
- N156 Intake manifold change-over valve
- N157 Ignition transformer output stage
- O Distributor
- P Spark plug socket
- Q Spark plugs
- S Fuse
- ST Fuse carrier
- V60 Throttle valve positioner
- V101 Secondary air pump motor
- Z19 Heater for lambda probe (upstream of catalytic converter)
- Z28 Heater for lambda probe 2
- Z29 Heater for lambda probe 1 (downstream of catalytic converter)

# Maintenance interval extension

## System components for service interval extension

The 88 kW engine has technical features which extend the vehicle's maintenance intervals. This has both economical and ecological benefits. In addition to the new engine production technology (reduced bearing clearance, precision honing), these features include a new type of oil and an engine oil sensor.

Customers can fully utilise the period up to the next service in accordance with their individual driving style and conditions of use. The oil level and service requirements are indicated to the customer visually.

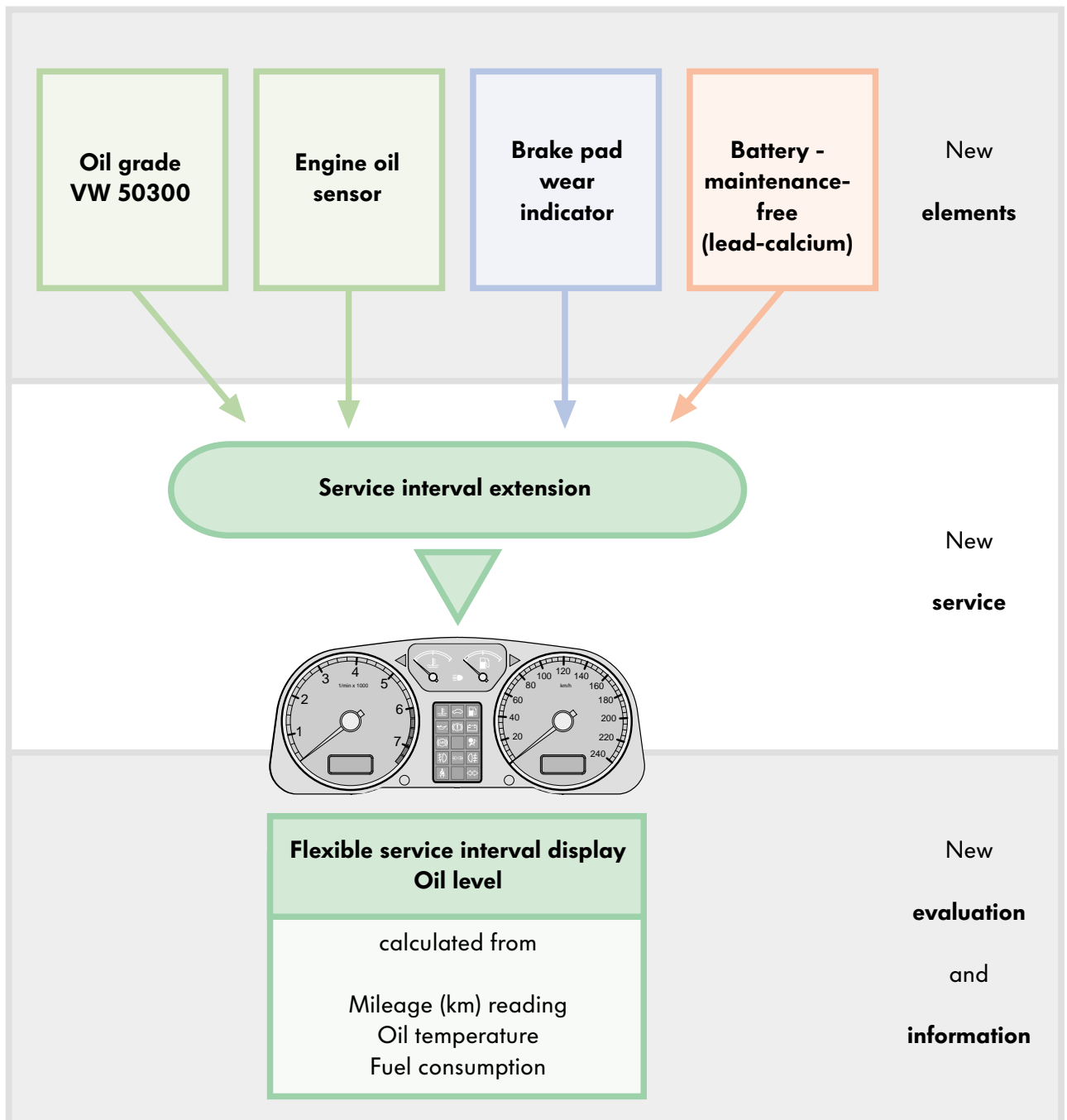

## The LongLife engine oil

This oil is a specially developed, non-ageing quality multi-purpose oil which conforms to the VW standard.

It can be used as an all-weather oil—except in extremely cold climatic zones—withstands higher loads for longer and is of a higher grade than conventional oil.

First Fill Service:

### VW 50300

The oil change interval within the service interval extension service is **2 years or max. 30,000 km**

for the 2.0-litre petrol engine

The exact point in time at which the oil change takes place varies from one vehicle to another. The oil change interval is determined as a factor of fuel consumption, driving style and oil temperature and is indicated on the dash panel insert.

Fuel consumption is reduced by 3%.



- These engine oils are the prerequisites for service interval extension. Only these oils should be used to refill the engine.
- No more than 0.5 litres of a different oil type may be mixed with these engine oils.



233\_046

### Oil change intervals



See also SSP 224.



# Maintenance interval extension

## Sender for oil level/temperature G266 (engine oil sensor)

The sender for oil level/temperature is installed at the bottom of the engine oil sump.

When the ignition is turned on, filling level and temperature data are acquired continuously.

These data are sent to the control unit for the display unit in the dash panel insert in the form of an output signal.

Here, they are processed together with other input variables for the flexible Service Interval Display.

In addition to oil level and oil temperature, fuel consumption in l/h per cylinder, the mileage reading and bonnet opening (via the bonnet contact) - as an attribute of an oil refill - are used for the flexible Service Interval Display.

The present condition of the engine oil in the vehicle is determined in the dash panel insert by evaluating these influencing factors. The upper limit values are variably adapted until the next service.

The system indicates to the driver that the next oil service is due 3,000 km before the next service interval elapses.

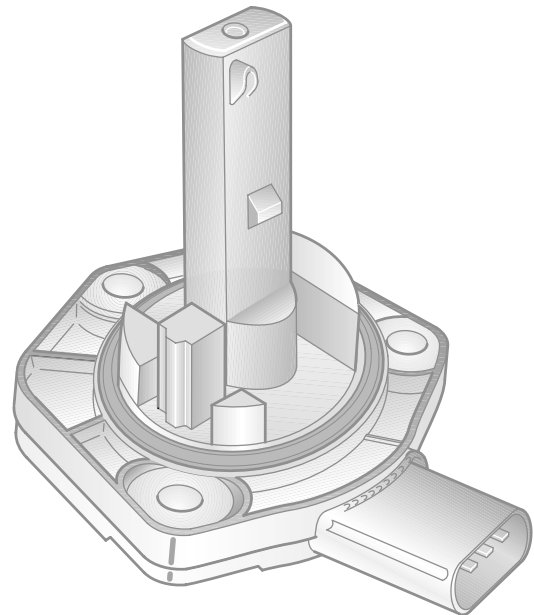

233\_047

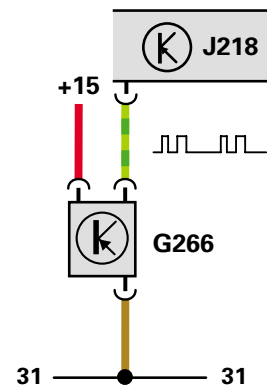

233\_048

G266 Sender for oil level/temperature  
J218 Control unit for display unit in dash panel insert

## Oil level indicator

The conventional warning lamp for engine oil pressure is also used as an oil level indicator.

If the yellow LED is continuously on  
= oil level too low

If the yellow LED is flashing  
= sender for oil level defective

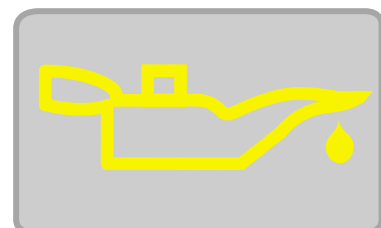

233\_049

An excessively high oil level is not indicated.

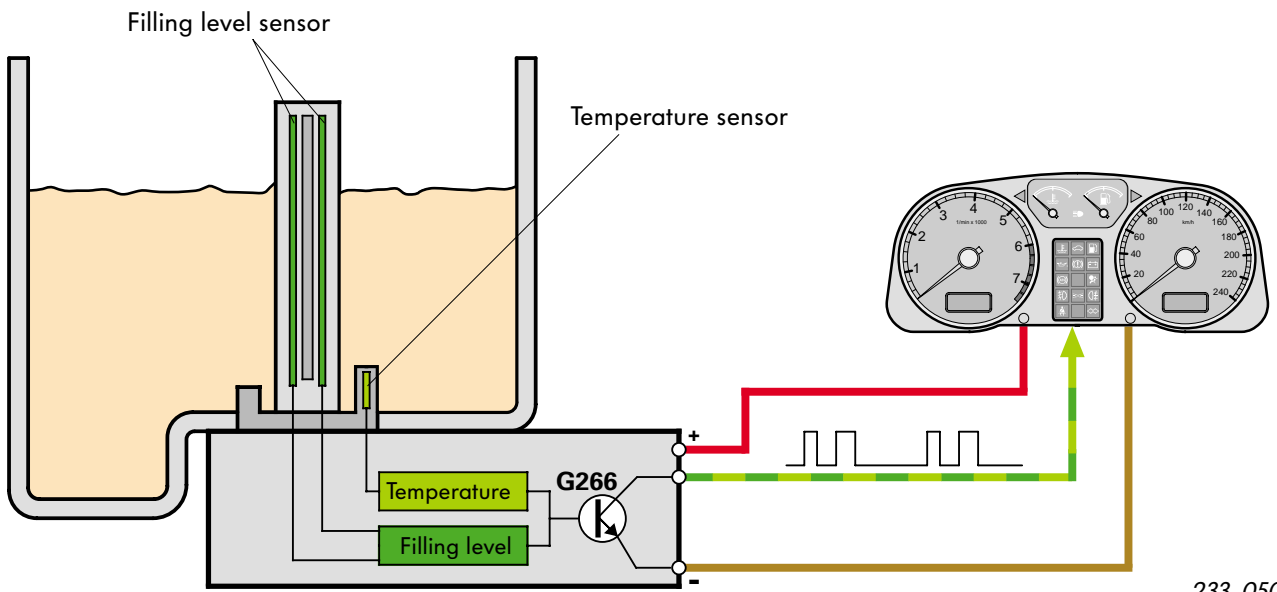

### Signal waveform and evaluation

The measuring element is briefly heated via the present oil temperature (output = High) and then cools down again (output = Low).

This procedure is repeated continuously. The High times are dependent on the oil temperature and the Low times are proportional to the filling level.

### Oil level

The oil level can be calculated in mm from the cool-down time during the cool-down phase by means of a sensor equation. The calculation is accurate to approx.  $\pm 2$  mm.

The more oil there is in the oil sump, the quicker the sensor will cool down again.

Long cool-down time = low oil level

Short cool-down time = normal

### Oil temperature

During the cool-down phase of the sensor, the oil temperature signal is also transmitted.

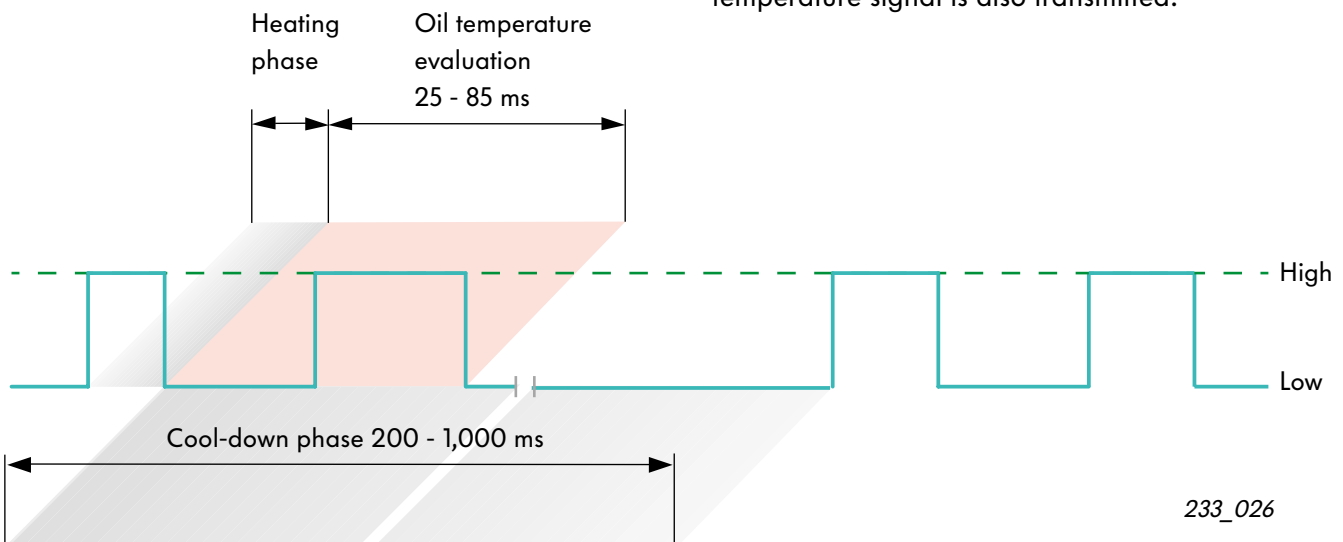

# Test your knowledge

---

Which of these answers is/are correct?

Sometimes only one answer is correct.

However, more than one or all of the answers may be correct.

Please fill in the gaps.

1. The position of the camshaft in the AQY engine is indicated by Hall sender G40. It has
  - A. a measurement window with the same width for each cylinder,
  - B. four different measurement windows,
  - C. two narrow measurement windows and two wide measurement windowswhich generate a characteristic signal for each 90° crankshaft rotation .
  
2. The injectors of the AQY engine are
  - A. identical to those used in the 1.6-litre and 1.8-litre engines.
  - B. also fitted with an air shroud.
  - C. of the so-called "top feed" type.
  
3. The crankcase has a breather to compensate for pressure differences. The mixture of gas and oil vapour is ..... recirculated. To prevent the mixture condensing on entry, the inlet is heated. This process takes place
  - A. throughout winter operation.
  - B. continuously when the ignition is "on".
  - C. during the starting cycle (much like a diesel glow plug).
  
4. By injecting additional air (secondary air) into the exhaust gas, the pollutants in the exhaust gas are recombusted. As a result,
  - A. the catalytic converter reaches its operating temperature quickly.
  - B. the pollutant components CO and HC are reduced.
  - C. the engine runs with an air surplus.
  
5. The secondary air system is
  - A. continuously active.
  - B. only active during the cold start phase.
  - C. active during the cold start phase and in the idling phase after a warm start.
  - D. featured in both engines.



- 
6. The combination valve in the secondary air system on the ATU engine
- A. is activated electro-pneumatically by the engine control unit.
  - B. is a vacuum controlled pneumatic valve.
  - C. is a pneumatic valve which is activated by a separate electro-pneumatic valve.
7. The advantages of the twin-probe lambda control are:
- A. Quick and precise lambda control.
  - B. The conversion efficiency of the catalytic converter is checked.
  - C. Malfunctioning of the catalytic converter is detected by comparing the probe voltages with a setpoint.
8. The readiness code
- A. indicates that diagnoses are in progress to ensure vehicle operation in conformity with the prescribed emission limits.
  - B. indicates faults in the exhaust emission control system.
  - C. can be generated and read out.
9. The new Motronic 5.9.2 is a generation of engine control units featuring
- A. technical improvements for starting the engine, low fuel consumption and reduced exhaust emission.
  - B. technical control systems for intake air temperature stabilisation.
  - C. meeting the requirements for OBD II.
10. The ATU and AQY engines have different
- A. distributors.
  - B. engine mounts.
  - C. numbers of knock sensors.

1. C.; 2. B., C.; 3. in the intake manifold, B.; 4. A., B.; 5. C., D.; 6. C.; 7. A., B., C.; 8. A., C.; 9. A., C. 10. A., B., C.



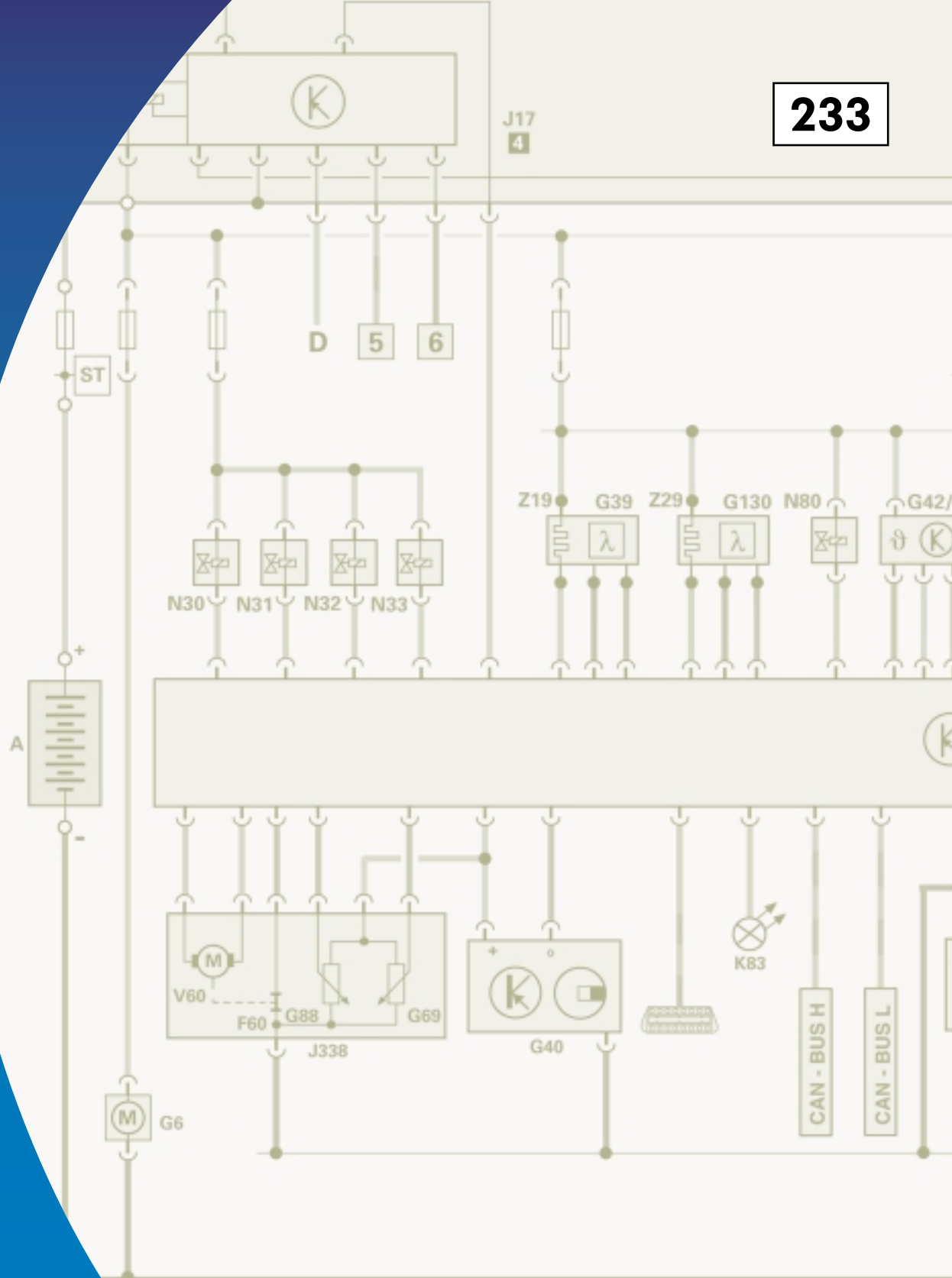

For internal use only © VOLKSWAGEN AG, Wolfsburg

All rights reserved. Technical specifications subject to change without notice.

940.2810.52.20 Technical status: 08/99

 This paper is produced from non-chlorine-bleached pulp.