

Engine code-PG

Accelerator cable

- [checking/adjusting](#)

Carbon canister

- [component layout](#)
- [shutoff valve, checking](#)

Fuel delivery rate

- [checking](#)

Fuel pump

- [afterrun, checking](#)
- [checking](#)
- [check valve, checking](#)
- [relay, checking](#)
- [removing/installing](#)

Fuel supply system

- [component layout](#)

Rules of cleanliness

- [chart](#)

Engine code AAA

Accelerator cable

- [checking adjusting](#)

Carbon canister

- [component layout](#)

Fuel delivery rate

- [checking](#)

Fuel pump

- [check valve checking](#)
- [checking](#)
- [relay checking](#)

Fuel supply/fuel pump assembly

- [installation position](#)
- [removing/installing](#)

Fuel supply system

- [component layout](#)

Rules of cleanliness

- [chart](#)

Vent valve

- [checking](#)

Volkswagen Corrado 1990 - 1994

Fuel Systems Supercharger Exhaust Engine Electrical

Fuel Supply (Page 20-2)

Accelerator cable, adjusting, [page 20-9](#)

Fuel pump relay, checking, [page 20-12](#)

Fuel pump afterrun, checking, [page 20-13](#)

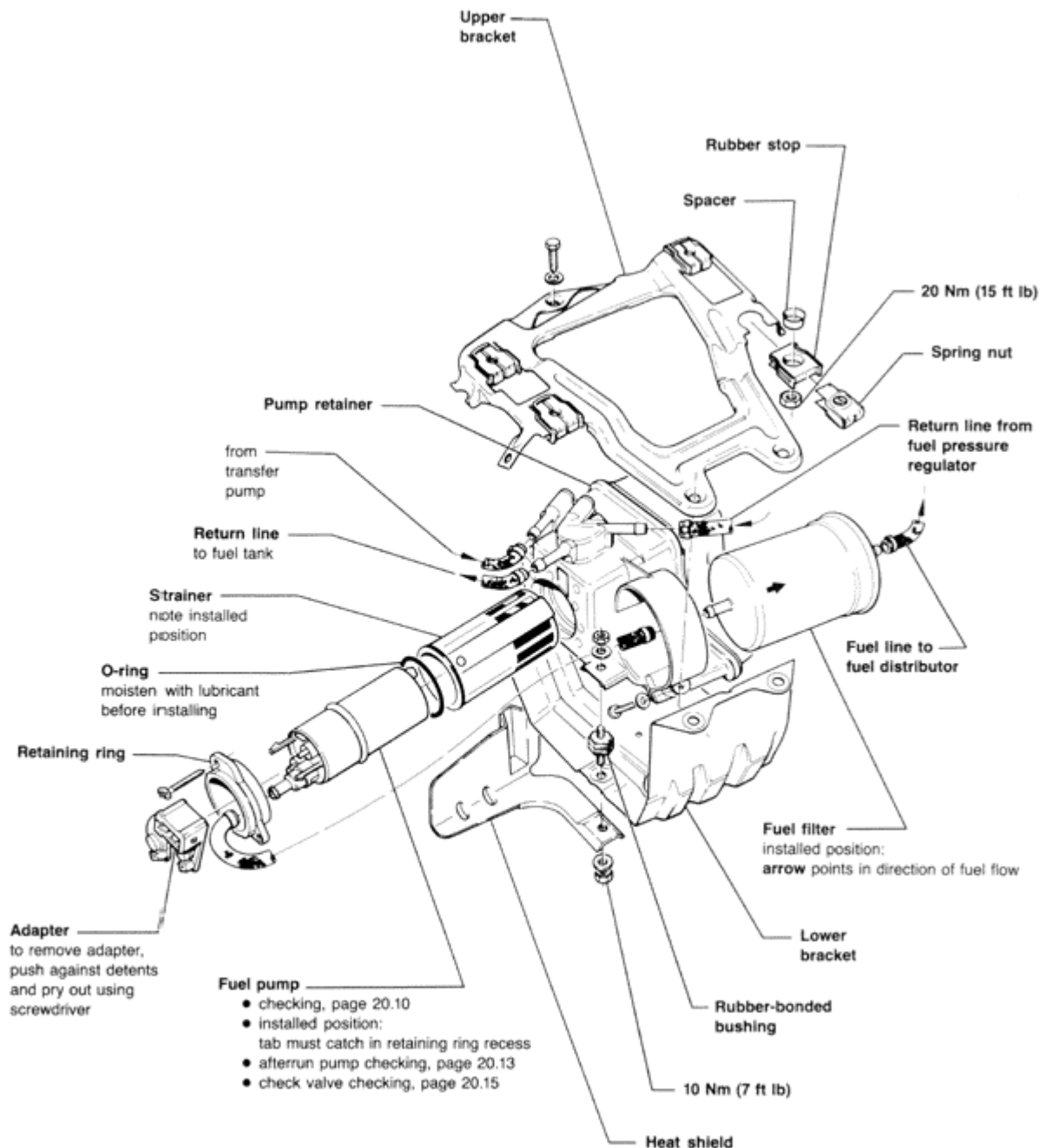

20-778

Notes

- always replace sealing rings when doing repair
- hose connections are secured with either screw clamps or spring clamps. However;

when replacing always use screw clamps

Volkswagen Corrado 1990 - 1994

Fuel Systems Supercharger Exhaust Engine Electrical

Fuel Supply (Page 20-3)

Notes

Replace spring clamps with screw clamps.

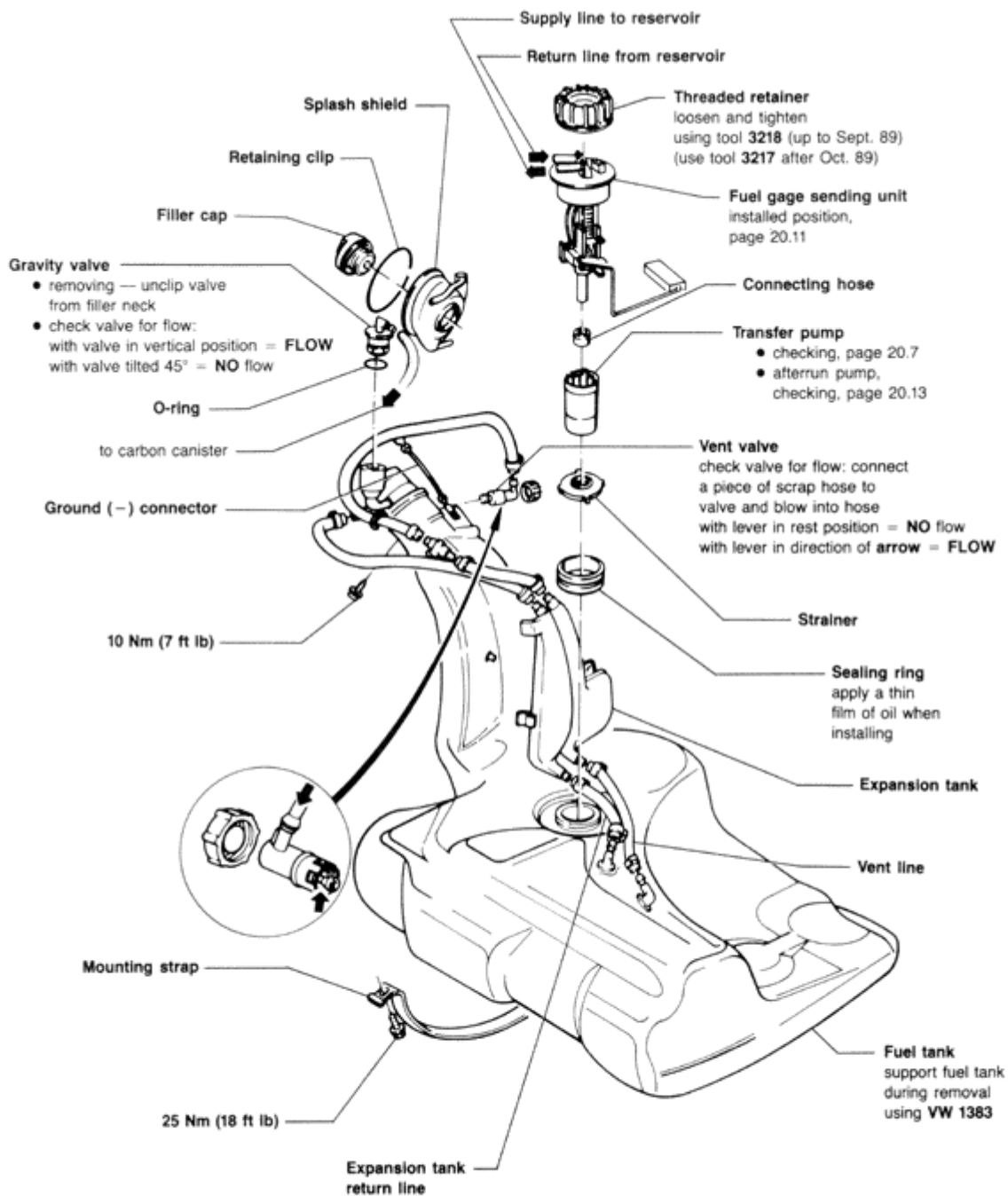

Notes

Sender with transfer pump is an assembly.

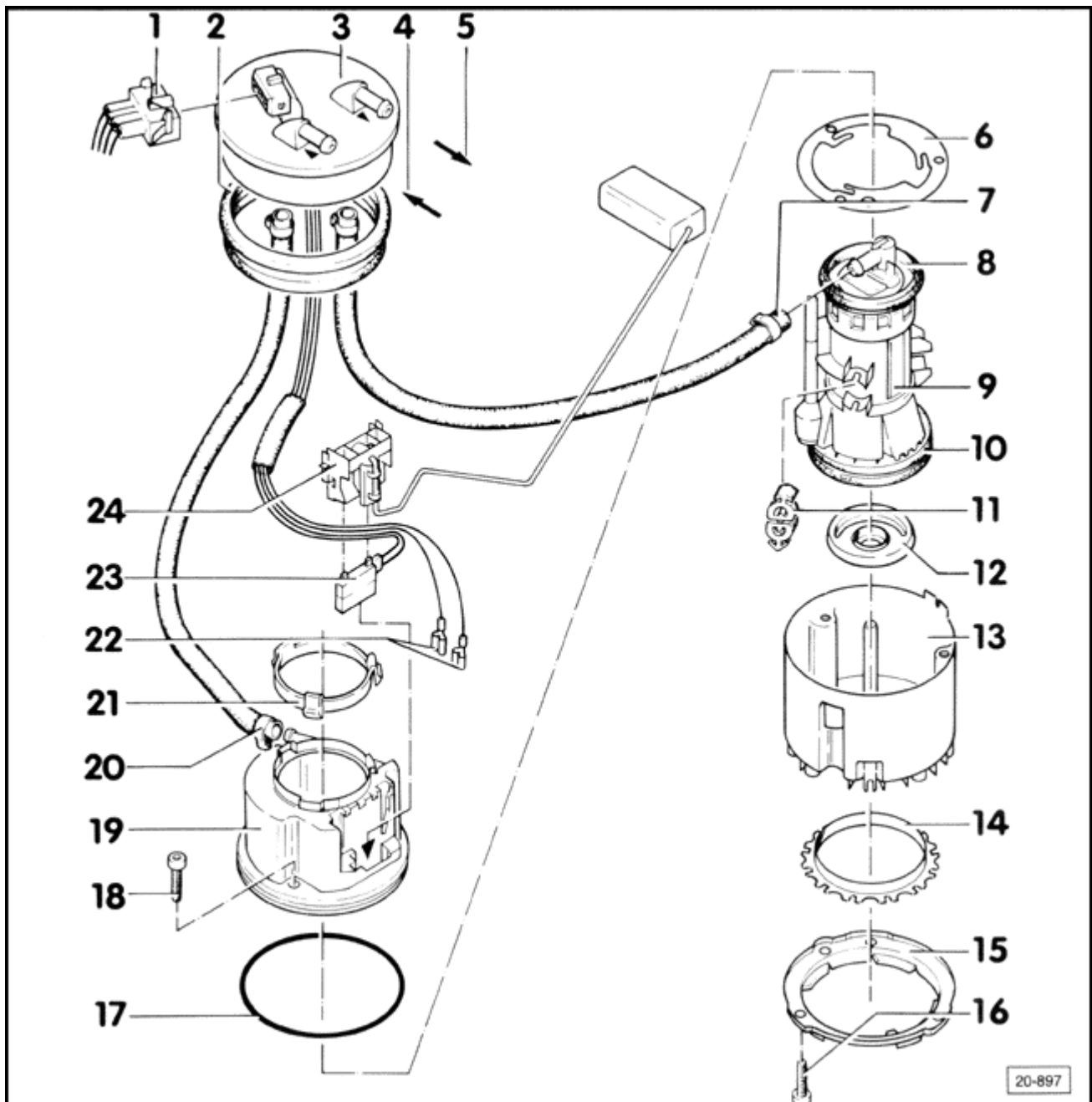

Notes

Threaded retainer (not shown) -loosen and tighten using tool **3217**

Starting with October 1989 production the fuel supply system was revised by installing the fuel pump into the fuel tank and eliminating the reservoir assembly and transfer pump.

WARNING!

When removing or installing the fuel pump provide adequate ventilation in the trunk area by drawing off any gasoline fumes with an approved exhaust vent or equivalent.

Avoid the possibility of fuel contacting your hands by using disposable gloves.

- secure all hose connections using screw type clamps
- observe the Rules of Cleanliness, see [page 20-6](#)

1 - Fuel gauge sending unit harness connector

2 - Sealing ring

3 - Flange assembly

4 - Return port from fuel pressure regulator

- 5 - Supply port to fuel filter**
- 6 - Retaining ring**
- 7 - Pre-supply hose**
- 8 - Sealing ring, upper**
 - pull in through upper housing (**19**) and fasten using lock ring (**21**)
- 9 - Fuel pump**
 - removing/installing [page 20-11](#)
 - delivery quantity, checking [page 20-7](#)
- 10 - O-ring, lower**
 - pull into lower housing and attach using rings (**14 and 15**)
- 11 - Deadener rubber**
 - between fuel pump and retaining ring (**6**)
- 12 - Filter/strainer**
- 13 - Housing, lower section**
- 14 - Retaining ring, lower**
- 15 - Bayonet ring**
- 16 - Screw**
- 17 - O-ring**
- 18 - Screw**
- 19 - Housing, upper section**
- 20 - Return hose**
- 21 - Retaining ring, upper**
 - unclip using screwdriver
- 22 - Electrical terminals for fuel pump**
- 23 - Harness connector for fuel gauge sending unit**
- 24 - Fuel gauge sending unit**

Rules of Cleanliness

CAUTION!

When working on the fuel supply/ injection system, carefully observe the following rules:

- 1 *Thoroughly clean connection and surrounding areas before loosening connection.*
- 2 *After removing components, place in clean area and cover with foil or paper.*
 - *Avoid using rags!*
- 3 *Components which have been opened or disassembled must be carefully covered or sealed if repair cannot be carried out immediately.*
- 4 *Install clean parts only.*
 - *remove replacement parts from package just before installing*
 - *do NOT use spare parts that were stored loose or unpackaged (e.g. in tool boxes, etc.)*
- 5 *When fuel system is open:*
 - *avoid using compressed air whenever possible*
 - *avoid moving the vehicle whenever possible*

Fuel delivery rate, checking

Applies to both single and two pump systems.

WARNING!

Fire hazard. Do not have anything in area that can ignite fuel.

Requirements

- supply voltage **OK**
- remote control **VAG 1348/3A** connected
- remove fuel filler cap

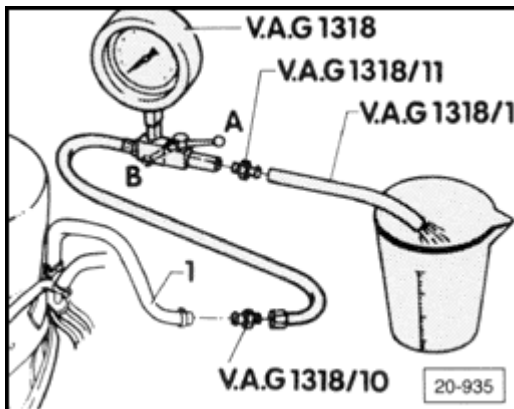

A

- connect **VAG 1318** pressure tester to pre-supply line 1 using a length of scrap hose and adaptor **VAG 1318/10**
- insert hose **VAG 1318/1** onto adaptor **VAG 1318/11** of pressure tester and hold in measuring glass
- open shutoff valve of tester **VAG 1318** (lever points in direction of flow) position **A**
- operate remote control **VAG 1348/3A** while slowly moving tester shutoff lever in direction **B** until the following pressure is indicated on the tester
 - two pump system (prior to 9-89 production): 3 bar (43.5 psi)
 - single pump system (from 10-89 production): 4 bar (58 psi)

When the indicated pressure is obtained stop moving the valve lever

- shut off remote control
- drain measuring glass
- operate remote control for 30 seconds then shut off
- compare quantity of accumulated fuel in measuring glass with appropriate chart

Volkswagen Corrado 1990 - 1994

Fuel Systems Supercharger Exhaust Engine Electrical

Fuel Supply (Page 20-8)

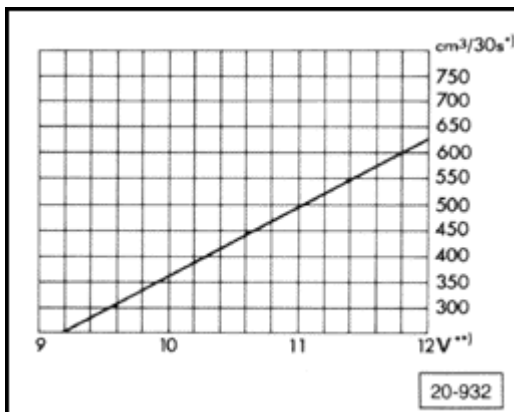

A

- up to 9-89, system with two pumps
 - * minimum supply per 30 seconds
 - ** voltage of running fuel pump with engine **NOT** running (should be approximately 2 volts less than battery voltage)

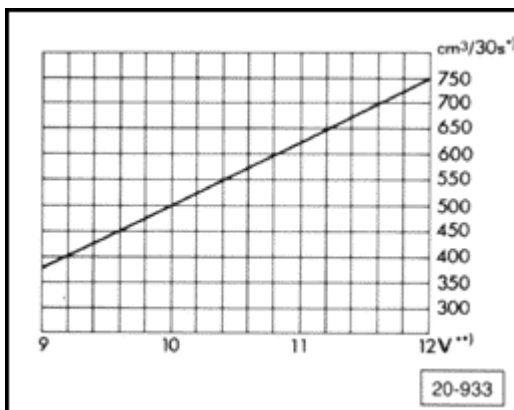

A

- from 10-89, system with one pump
 - * minimum supply per 30 seconds
 - ** voltage of running fuel pump with engine **NOT** running (should be approximately 2 volts less than battery voltage)

If minimum delivery value NOT obtained

- check if fuel lines are bent, pinched or plugged; repair as necessary
- check if fuel filter is plugged, replace if necessary

Notes

The chart is expressed in units of cubic centimeters (cc's). It is also acceptable to substitute milliliters (ml) for cc's.

This will allow you to use containers calibrated in cc's or ml's with equal results.

- 1 milliliter = 1 cubic centimeter

Accelerator cable, checking/ adjusting

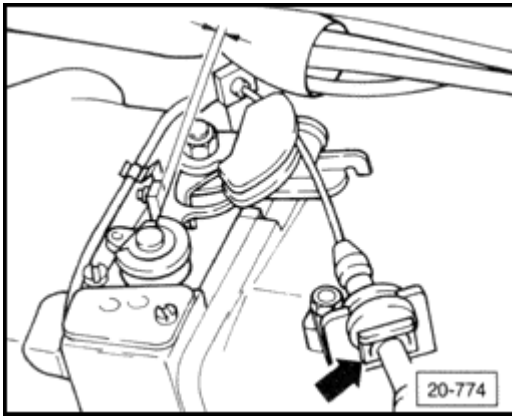

Checking

- depress accelerator pedal fully (to floor stop)
 - throttle valve must just reach full throttle position (maximum of 1 mm of play at throttle valve lever)

If NO

- adjust as follows

Adjusting

- remove retaining clip (**arrow**) and reposition slotted portion of cable
 - (until checking condition is met)
- re-insert positioning clip
- verify that checking condition is met

Volkswagen Corrado 1990 - 1994

Fuel Systems Supercharger Exhaust Engine Electrical Fuel Supply (Page 20-10)

Fuel pump, checking

Supply voltage, checking

Check these first:

- fuse **18 OK**
- ignition coil wire removed from distributor and connected to ground using jumper wire/clip
- crank starter for 3-4 seconds
 - fuel pumps **MUST** be audible for short time

If **NO**

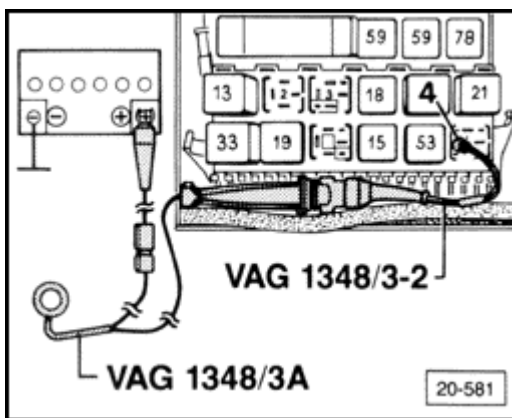

A

- remove fuel pump relay from fuse relay panel (**arrow**)
- connect remote control adaptor **VAG 1348/3-2** to terminal **4** of fuel pump relay socket
- connect adaptor lead from remote control **VAG 1348/3A** to battery (+)
- activate remote control
 - fuel pumps should run audibly

If **YES**

- replace fuel pump relay

If **NO** or only one pump runs:

- disconnect transfer pump harness connector
- connect **US 1115** LED tester to middle wire and outer brown wire
- operate remote control
 - LED must light up

If **NO**

- check wiring using wiring diagram, repair as necessary

If **OK**

- replace fuel pump(s)

Fuel supply assembly/fuel pump, removing and installing

Notes

This page refers to single pump systems installed since 10-89.

*Numbers refer to exploded view **20-897** on [page 20-4](#).*

WARNING!

Fire hazard. Do not have anything in area that can ignite fuel.

To remove fuel supply assembly

- remove trunk floor cover
- disconnect harness connector and fuel lines from flange **3**

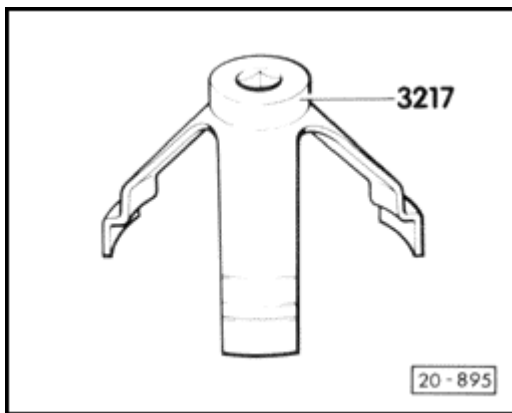

A

- unscrew flange nut using special tool **3217**
- withdraw flange **3** and O-ring **2** from opening on fuel tank
- loosen and remove supply unit from bayonet lock by turning to the left

Notes

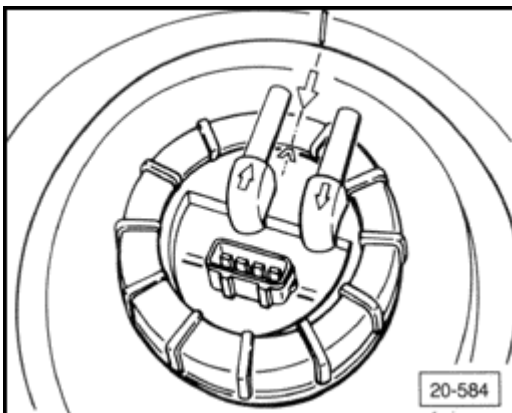

A

*When installing be sure that sender **24** is neither bent nor pointing towards the front of the tank. The correct position is obtained by aligning the arrows as shown in the illustration.*

To remove fuel pump

Requirement

-

remove fuel supply assembly

- remove fuel gauge sending unit **24**, connector **22**, connector **23**, hoses **7** and **20** from supply assembly
- unclip upper retaining ring **21** using screwdriver
- unscrew bolts **18** and remove upper housing **19** from lower housing **13**
- installation is reverse of removal procedure

CAUTION!

Carefully install O-rings 8 and 10 in the upper and lower housings. Do not pinch, roll or misalign before tightening.

Fuel pump relay, checking

Symptom: Fuel pumps **NOT** running when ignition is switched **ON**.

Check this first

- fuse **18** OK

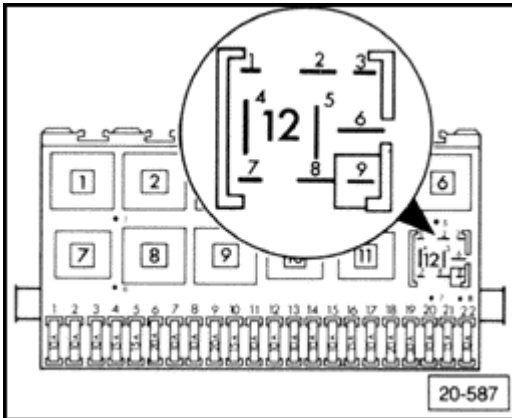

A

- remove fuel pump relay from fuse relay panel (**arrow**)
- switch ignition **ON**
- connect **US 1115** LED tester as follows:
 - between terminal **6** and ground (-)
 - between terminal **2** and ground (-)
 - between terminals **6** and **4** LED must light up

If **NO**

- check wiring using wiring diagram, repair as necessary
- switch ignition **OFF**
- connect **US 1115** LED tester between terminals **2** and **3**
- switch ignition **ON**
 - LED must light up for approximately **1** second

If **NO**

- check for open circuit in wiring to control unit using wiring diagram

If circuit **OK**

- replace fuel injection control unit

Fuel pump afterrun, checking

Check this first:

- battery voltage **OK**
- fuel tank must be 1/4 full, minimum

WARNING!

Fire hazard. Do not have anything in area that can ignite fuel.

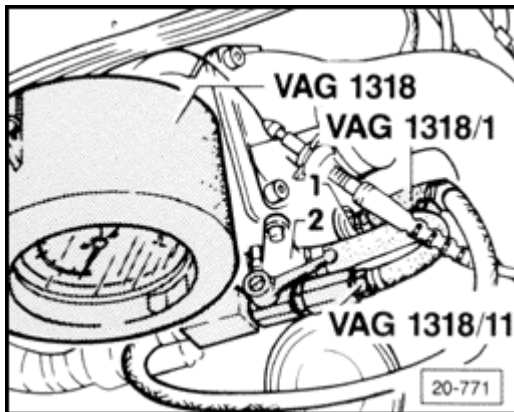

A

- connect pressure tester **VAG 1318** using adaptors **1318/1** and **1318/11** between fuel distributor **1** and pressure switch **2**

Notes

The shutoff valve must be open (lever in direction of fuel flow).

CAUTION!

When loosening the line at the fuel distributor, place a rag around the connection to avoid the risk of being sprayed.

- start engine and run at idle
- observe fuel pressure
 - approximately 2.5 bar (36.3 psi)
- switch ignition **OFF**

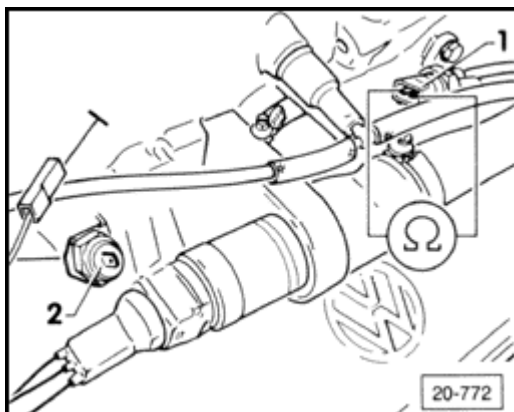

A

Remove harness connector from pressure switch **1** and measure resistance between pressure switch terminals.

- 0 Ohms approximately
- remove harness connector from ambient temperature switch for fan afterrun **2** and connect to ground (-) using adaptor wire from **VW 1594** kit
- radiator fan **MUST** run
- re-connect pressure switch harness connector

Volkswagen Corrado 1990 - 1994

Fuel Systems Supercharger Exhaust Engine Electrical

Fuel Supply (Page 20-14)

- switch ignition **ON** then switch **OFF**
 - after about 2-3 minutes fuel pumps **MUST** run

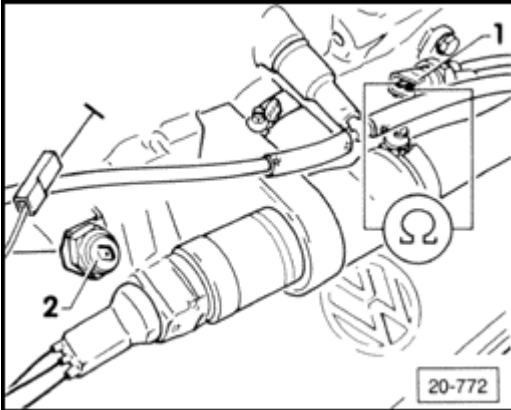

- A**
- re-connect ambient temperature switch harness connector
 - fuel pump must **NOT** run
 - remove harness connector from pressure switch and measure resistance between terminals
 - 0 Ohms approximately

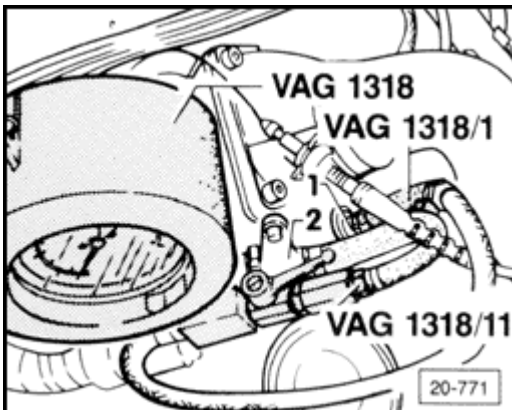

- A**
- reduce system pressure by carefully loosening pressure gage/adaptor **VAG 1318/1** at connection

CAUTION!

When loosening the adaptor place a rag around the connection to avoid the risk of being sprayed.

The switch must open (infinite ∞) when pressure drops below 1 bar (14 psi).

Fuel pump check valve, checking

Notes

This leak test includes the entire fuel supply line from the fuel pump to the **VAG 1318** tester.

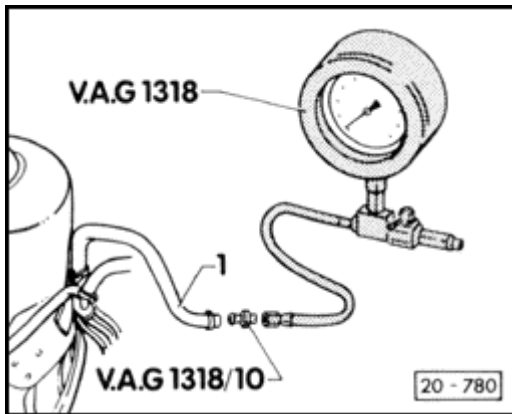

A

- remove (**black**) fuel supply line **1** on fuel distributor and connect to **VAG 1318** pressure gage using adaptor **VAG 1318/10**

CAUTION!

*Pressure gage shutoff lever **MUST** be closed (lever at right angles to direction of fuel flow).*

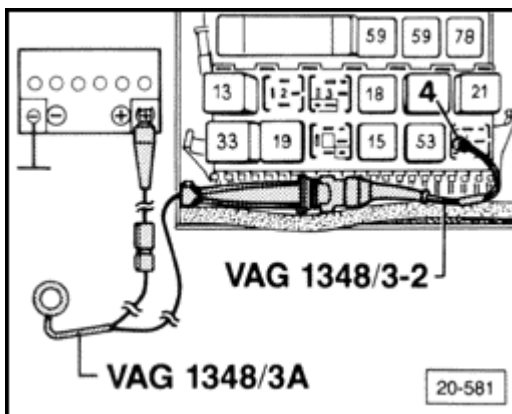

A

- remove fuel pump relay from fuse relay panel (**arrow**)
- connect remote control adaptor **VAG 1348/3-2** to terminal **4** of fuel pump relay socket
- connect adaptor lead from remote control **VAG 1348/3A** to battery (+)
- activate remote control for brief intervals until a pressure of approximately 3 bar (43.5 psi) has accumulated
- reduce pressure over 3 bar to approximately 2 bar (29 psi) by **CAREFULLY** opening the shutoff valve a small amount

CAUTION!

There is a risk of being sprayed when opening the shutoff valve. Hold a rag in front of the pressure gage connector.

- note pressure drop, pressure must **NOT** fall below 2.0 bar (29 psi) after 10 minutes

If **YES**

- check line connectors for leakage and replace fuel pump, if necessary

Volkswagen Corrado 1990 - 1994
Fuel Systems Supercharger Exhaust Engine Electrical
Fuel Supply (Page 20-16)

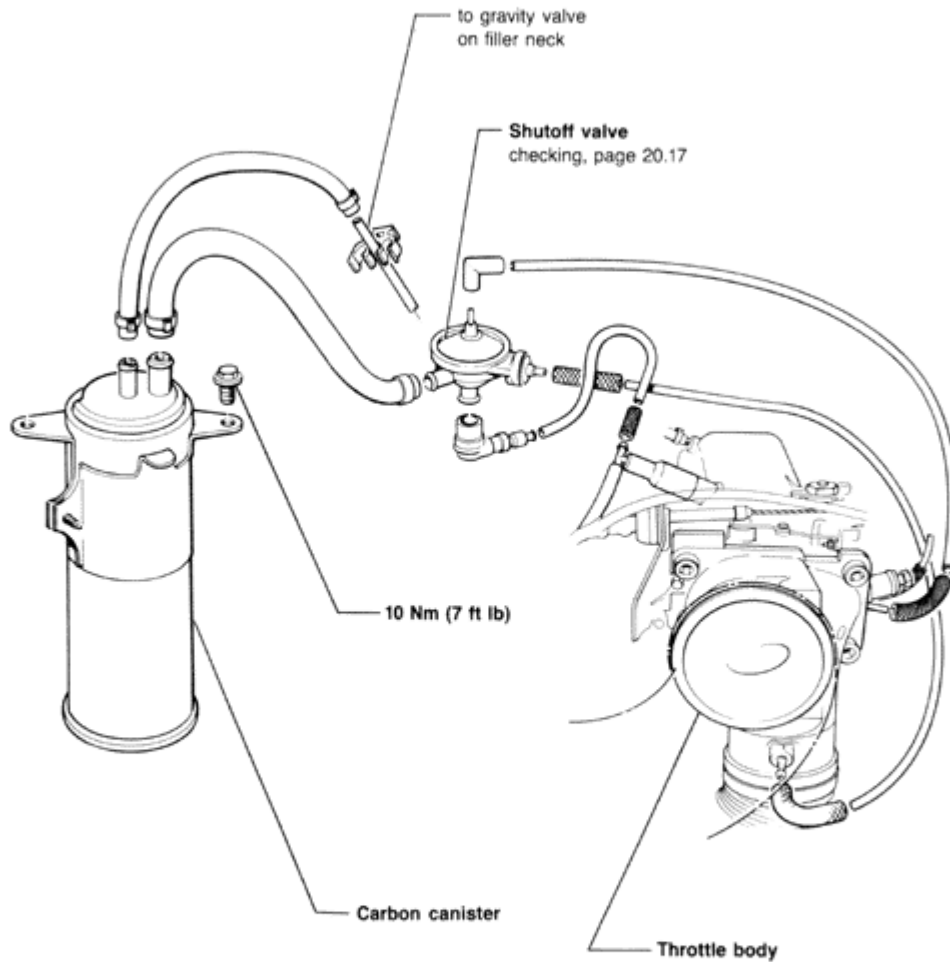

Carbon canister shutoff valve, checking

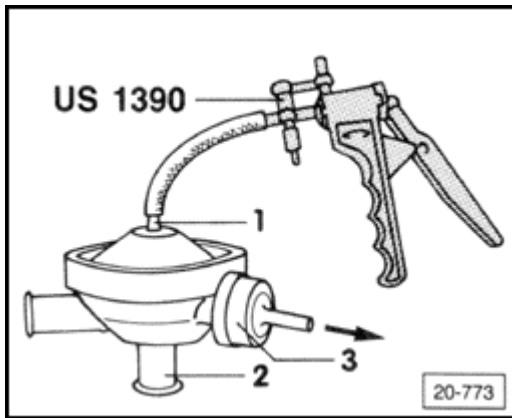

A

- connect hand vacuum pump **US 1390** to small diameter connector **1**
- with suction at connector **2**
 - valve must close
- operate vacuum pump
 - valve **MUST** open
- test check valve **3** . It must have flow in the direction of the **arrow** , and be closed in the opposite direction

If **NO**

- replace shutoff valve

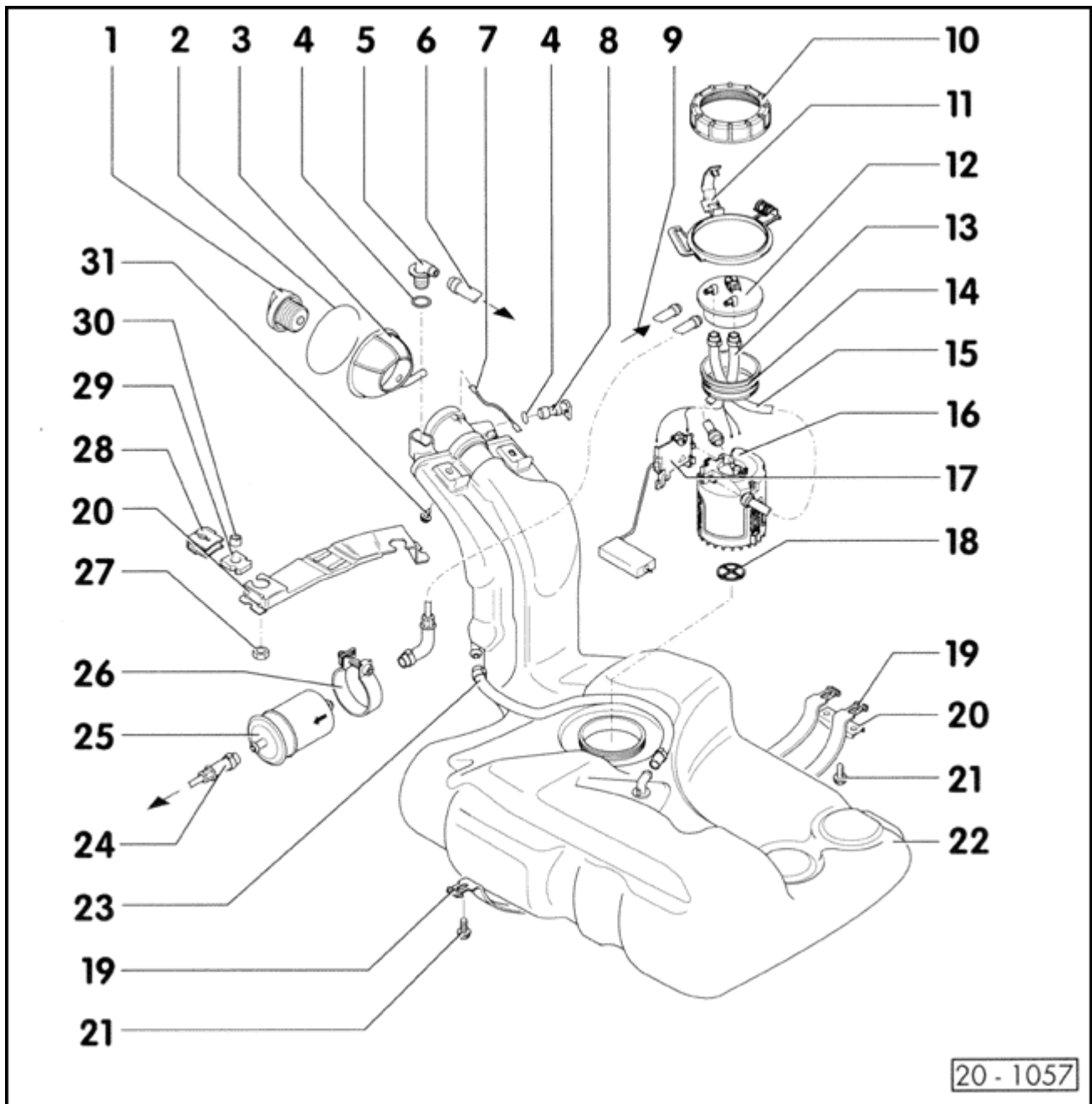

WARNING!

When removing or installing the fuel pump provide adequate ventilation in the trunk area by drawing off any gasoline fumes with an approved exhaust vent or equivalent.

Wear disposable gloves to avoid the possibility of fuel contacting your hands.

WARNING!

DO NOT re-use any fasteners that are worn or deformed in normal use. Many fasteners are designed to be used only once and become unreliable and may fail when used a second time. This includes, but is not limited to, nuts, bolts, washers, self-locking nuts or bolts, circlips, cotterpins. Always follow recommendation given in this publication. For replacements always use new parts.

Volkswagen Corrado 1990 - 1994

Fuel Systems Supercharger Exhaust Engine Electrical

Fuel Supply (Page 20-19)

Notes

- observe the Rules of Cleanliness, see [page 20-6](#)
- secure all hose connections using screw type clamps
- adjust accelerator cable, see [page 20-22](#)
- check fuel pump relay, see [page 20-30](#)
- remove/install carbon canister components, see [page 20-32](#)

1 - Filler cap

2 - Retaining clip

3 - Splash shield

4 - O-ring

replace

5 - Gravity valve

removing, unclip valve from filler neck and pull out from filler neck

6 - Vent line

to carbon canister, see [page 20-32](#)

7 - Ground (-) connector

8 - Vent valve

checking, see [page 20-21](#)

9 - Return line

- blue
- from fuel distributor, see [Repair Group 24](#)

10 - Threaded retainer

loosen and tighten with tool 3217

11 - Hose guide

12 - Flange

note installation position on fuel tank, see [page 20-24](#)

13 - Supply hose

14 - Sealing ring

coat with fuel before installing

15 - Return hose

16 - Fuel pump

removing/installing, see [page 20-23](#)

17 - Fuel gauge sending unit

18 - Filter/strainer

19 - Mounting strap

20 - Bracket

21 - 25 Nm (18 ft lb)

22 - Fuel tank

- removing: remove right rear wheel to remove tank, remove vent hose **23** at expansion tank

- support fuel tank during removal using support tool **VAG 1383A** or **OTC Model 1785A**

23 - Vent line

remove at expansion tank **before** removing fuel tank

24 - Fuel line

- black
- to fuel distributor, see [Repair Group 24](#)

25 - Fuel filter

installed position: **arrow** points in direction of flow

26 - Clamp

27 - 20 Nm (15 ft lb)

28 - Rubber stop

29 - Spring nut

30 - Spacer

31 - 10 Nm (7 ft lb)

Fuel supply/fuel pump assembly, installation position

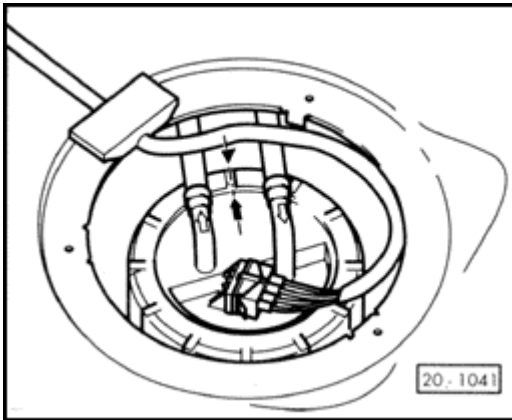

- mark on flange (**arrow**) must align with mark on fuel tank

Vent valve, checking

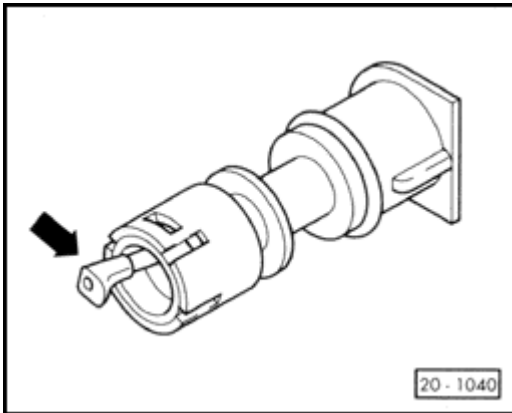

- lever in rest position: valve **closed**
- lever in direction of arrow: valve **open**

Accelerator cable, checking/adjusting

Manual transmission

Checking

- depress accelerator pedal fully (to floor stop)
 - throttle valve must just reach the wide open throttle position

Adjusting

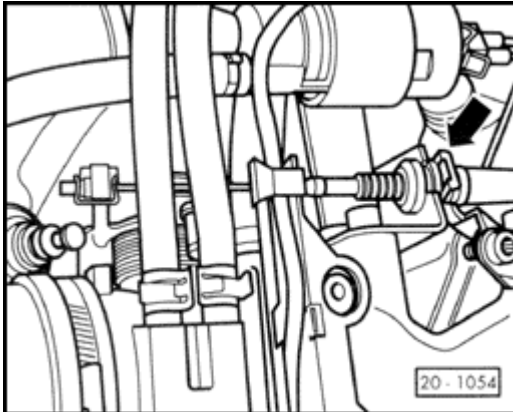

- remove retaining clip (**arrow**) and reposition slotted portion of cable
 - (until checking condition is met)
- re-insert positioning clip
- verify that checking condition is met

Throttle cable, checking and adjusting

Vehicles with automatic transmission

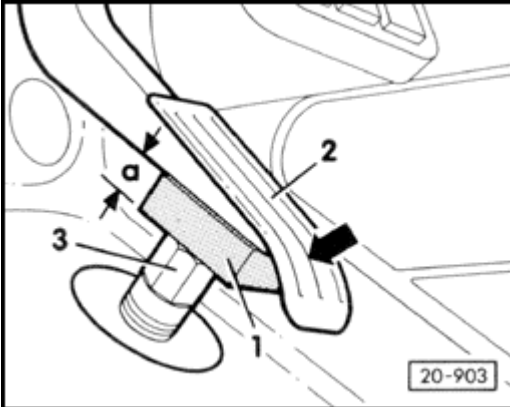

- position spacer 1 (which provides a space of $a = 15$ mm) between accelerator pedal 2 and pedal stop 3
- fully depress accelerator pedal until it contacts spacer and hold pedal in this position during the following adjustment

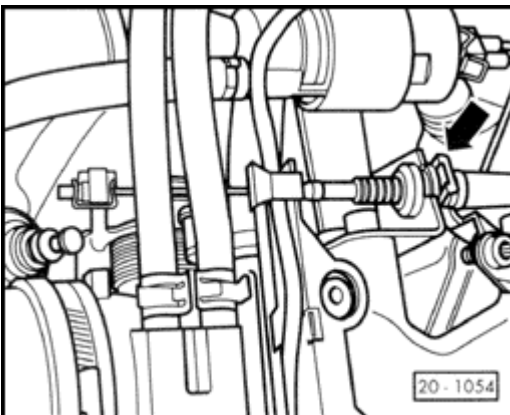

- fully open the throttle by pulling the outer cable and locate at this position using the retaining clip (arrow)
- release the accelerator pedal and remove the spacer

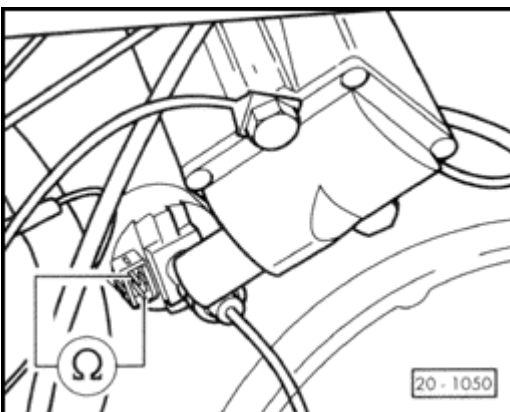

- connect Fluke 83 multimeter between terminals of kickdown switch using jumper wires from **VW 1594** adaptor kit
 - must be infinite Ohms (open)

- slowly depress throttle toward wide open throttle
 - shortly after the kickdown pressure point, resistance must fall to 0 Ohms (continuity)
 - when continuity is obtained, the accelerator pedal should be closely approaching contact with the pedal stop

Fuel pump assembly, removing/installing

Removing

WARNING!

Fire hazard. Do not have anything in area that can ignite fuel.

- switch ignition **OFF**
- disconnect battery ground strap

CAUTION!

Wait at least 20 seconds after switching off ignition before disconnecting battery. This will allow the platinum hot-wire in the Mass Air Flow (MAF) Sensor to burn itself clean.

CAUTION!

Always switch off ignition when disconnecting or reconnecting battery, or any part of Motronic system to prevent damage to Motronic engine control module (ECM).

CAUTION!

Always obtain radio security code before disconnecting battery ground strap.

- remove cover plate in luggage compartment floor
- disconnect harness connector and fuel lines from flange

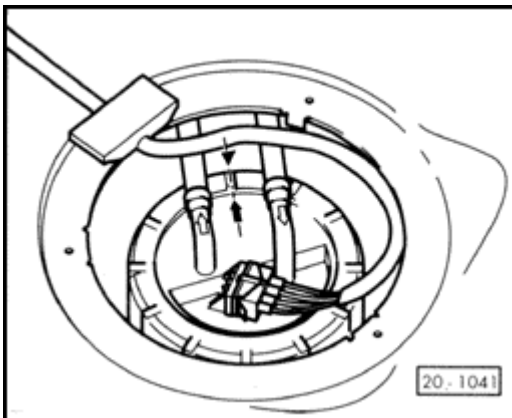

- unscrew flange nut using special tool **3217**
- withdraw flange and O-ring from opening on fuel tank
- loosen and remove supply unit from bayonet lock by turning to the left

Installing

Reinstall all components in reverse order, noting the following:

CAUTION!

Ensure that the sender is not bent when reinstalling.

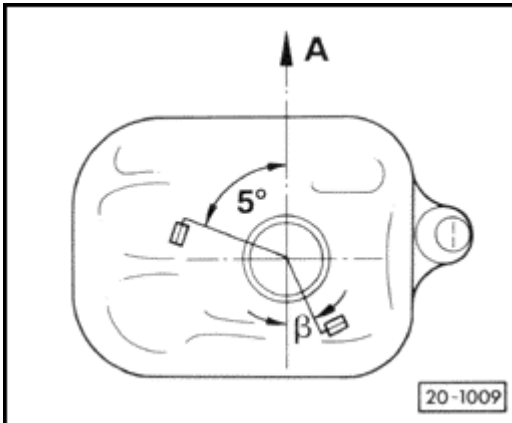

- fuel pump assembly is correctly installed when sender float angle (from direction of travel **A**) is 5°
- coat flange sealing ring with fuel before installing

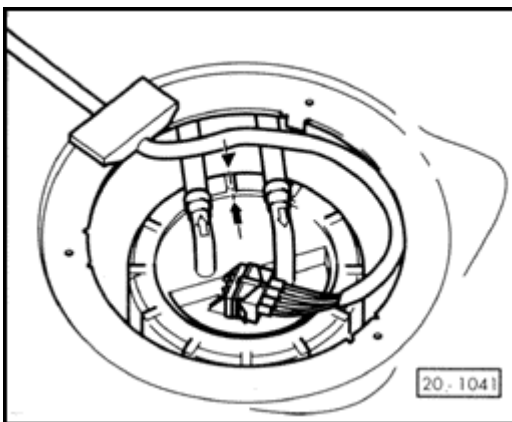

- align mark on flange with mark on fuel tank, as shown

Fuel pump, checking

Supply voltage, checking

Notes

Always refer to appropriate wiring diagram.

Requirements

- fuse **18 OK**
- battery **OK**
- switch ON ignition
- fuel pumps must be audible for approximately **1 second**

Volkswagen Corrado 1990 - 1994

Fuel Systems Supercharger Exhaust Engine Electrical

Fuel Supply (Page 20-26)

If **NO**

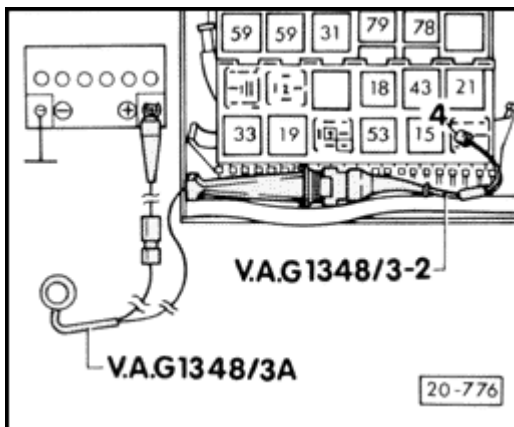

- remove fuel pump relay (**J 17**) from fuse/relay panel, position **12**
- connect remote control adaptor **VAG 1348/3-2** to terminal **4** of fuel pump relay socket
- connect adaptor lead from remote control **VAG 1348/3A** to battery positive (+)
- activate remote control switch
 - fuel pump must run

If **YES**

- check and replace fuel pump relay, see [page 20-30](#)

If **NO**

- remove cover plate in luggage compartment floor
- disconnect connector from flange on fuel tank

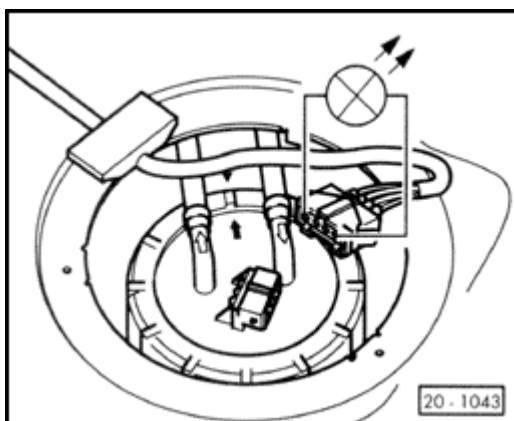

- connect **US 1115** LED Tester to the outer wires of the connector using jumper wires from **VW 1594** Adaptor Kit
- operate remote control
 - LED must light up

If **NO**

- check wiring, using appropriate wiring diagram, repair or replace as necessary

If **YES**

- remove ring nut with **3217**
-

check wiring between flange and fuel pump

If **OK**

- replace fuel pump, see [page 20-23](#)

Fuel delivery rate, checking

WARNING!

Fire hazard. Do not have anything in area that can ignite fuel.

Requirements

- supply voltage **OK**
- remote control adaptor lead **VAG 1348/3A** connected
- fuel filter **OK**

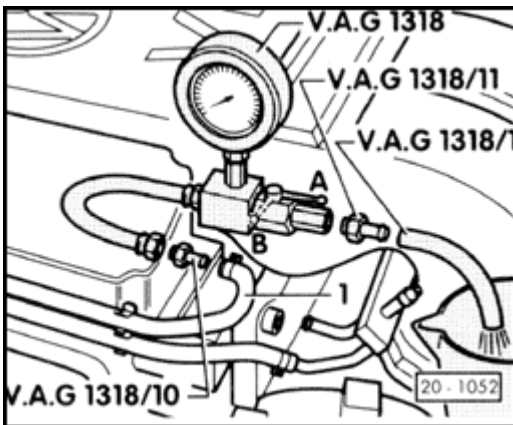

- remove fuel tank cap
- remove fuel supply line **1** on fuel rail

Notes

Cover connection with cloth to protect from fuel spray.

- connect **VAG 1318** pressure tester to the fuel supply line **1** with adaptor **VAG 1318/1A**
- insert hose **VAG 1318/1A** onto adaptor **VAG 1318/11** and hold in measuring glass
- open shutoff valve of tester **VAG 1318** (lever points in direction of flow) position **A**
- operate remote control **VAG 1348/3A** while slowly closing valve of tester until pressure tester indicates 4 bar (58 psi)

Volkswagen Corrado 1990 - 1994

Fuel Systems Supercharger Exhaust Engine Electrical

Fuel Supply (Page 20-28)

When the indicated pressure is obtained, stop moving the valve lever.

- switch **OFF** remote control
- empty measuring glass
- operate remote control for 30 seconds then shut off

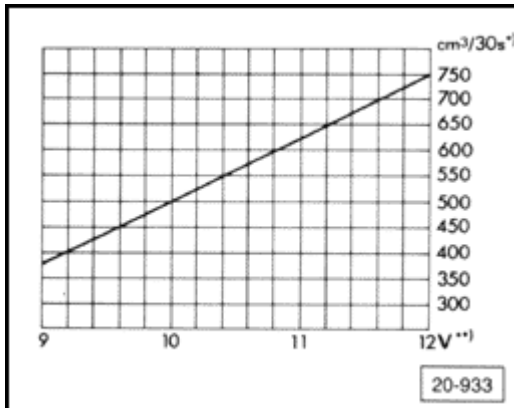

Notes

The chart is expressed in units of cubic centimeters (cc's). It is also acceptable to substitute milliliters (ml) for cc's.

- compare quantity of accumulated fuel in measuring glass with appropriate chart
 - * minimum supply per 30 seconds
 - ** voltage of running fuel pump with engine **NOT** running (should be approximately 2 Volts less than battery voltage)
- If minimum delivery **NOT OK**
- fuel lines bent, pitched or plugged; repair as necessary
 - check if fuel filter is plugged, replace as necessary
 - fuel pump faulty, replace if necessary, see [page 20-23](#)

Fuel pump check valve, checking

WARNING!

Fire hazard. Do not have anything in area that can ignite fuel.

Notes

This leak test includes the entire fuel supply line from the fuel pump to the **VAG 1318** tester.

- connect pressure tester **VAG 1318**
- connect remote control adaptor **VAG 1348/3A**

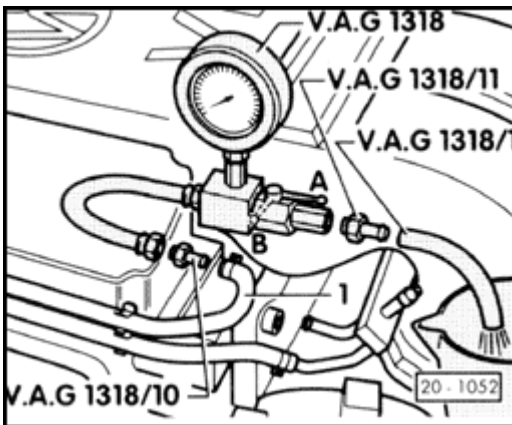

CAUTION!

Pressure gauge shutoff lever MUST be closed (lever at position B).

- activate remote control for brief intervals until a pressure of approximately 4 bar (58 psi) has accumulated
- reduce pressure if over 4 bar (58 psi) by **CAREFULLY** opening the shutoff valve a small amount

CAUTION!

There is a risk of being sprayed with fuel when opening the shutoff valve. Hold a measuring glass in front of the pressure gauge connector.

- note pressure drop, pressure must not drop below 3 bar (43.5 psi) within 10 minutes

If YES

- check line connectors for leakage and replace fuel pump, if necessary

Volkswagen Corrado 1990 - 1994

Fuel Systems Supercharger Exhaust Engine Electrical Fuel Supply (Page 20-30)

Fuel pump relay, checking

Symptom: Fuel pump **NOT** running when ignition is switched **ON** .

Notes

Always refer to the appropriate wiring diagram.

Requirement

- fuse 18 OK

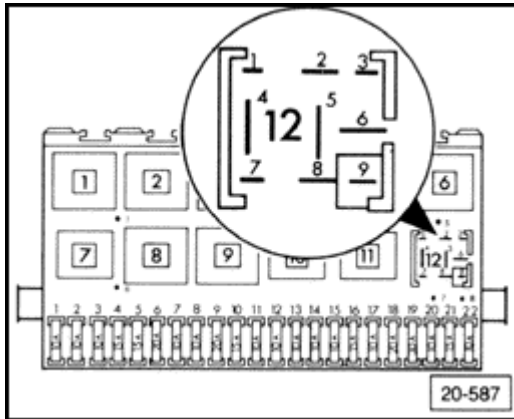

- remove fuel pump relay (**J 17**) from fuse relay panel (**arrow**) position **12**
- switch ignition **ON**
- using Adaptor Test Kit **VW 1594** connect **US 1115** LED Tester as follows:
 - between terminal **6** and ground (-)
 - between terminal **2** and ground (-)
 - between terminals **6** and **4**

LED must light up

If **NO**

- check wiring using wiring diagram, repair or replace as necessary

If **YES**

- switch ignition **OFF**
- using Adaptor Test Kit **VW 1594** , connect LED Tester between terminals **2** and **3**
- switch ignition **ON**
 - LED must light up for **1** second

If **NO**

- check triggering of fuel pump relay, see [Repair Group 01 \(Fuel Injection and Ignition\)](#) for testing using **VAG 1598** Test Box

Volkswagen Corrado 1990 - 1994
Fuel Systems Supercharger Exhaust Engine Electrical
Fuel Supply (Page 20-31)

If YES

- switch ignition **OFF**
- using Adaptor Test Kit **VW 1594**, connect LED Tester between terminals **2** and **3**
- switch ignition **ON**
 - LED must light up for **1** second

If NO

- check triggering of fuel pump relay, see [Repair Group 01](#) for testing with Test Box **VAG 1598**

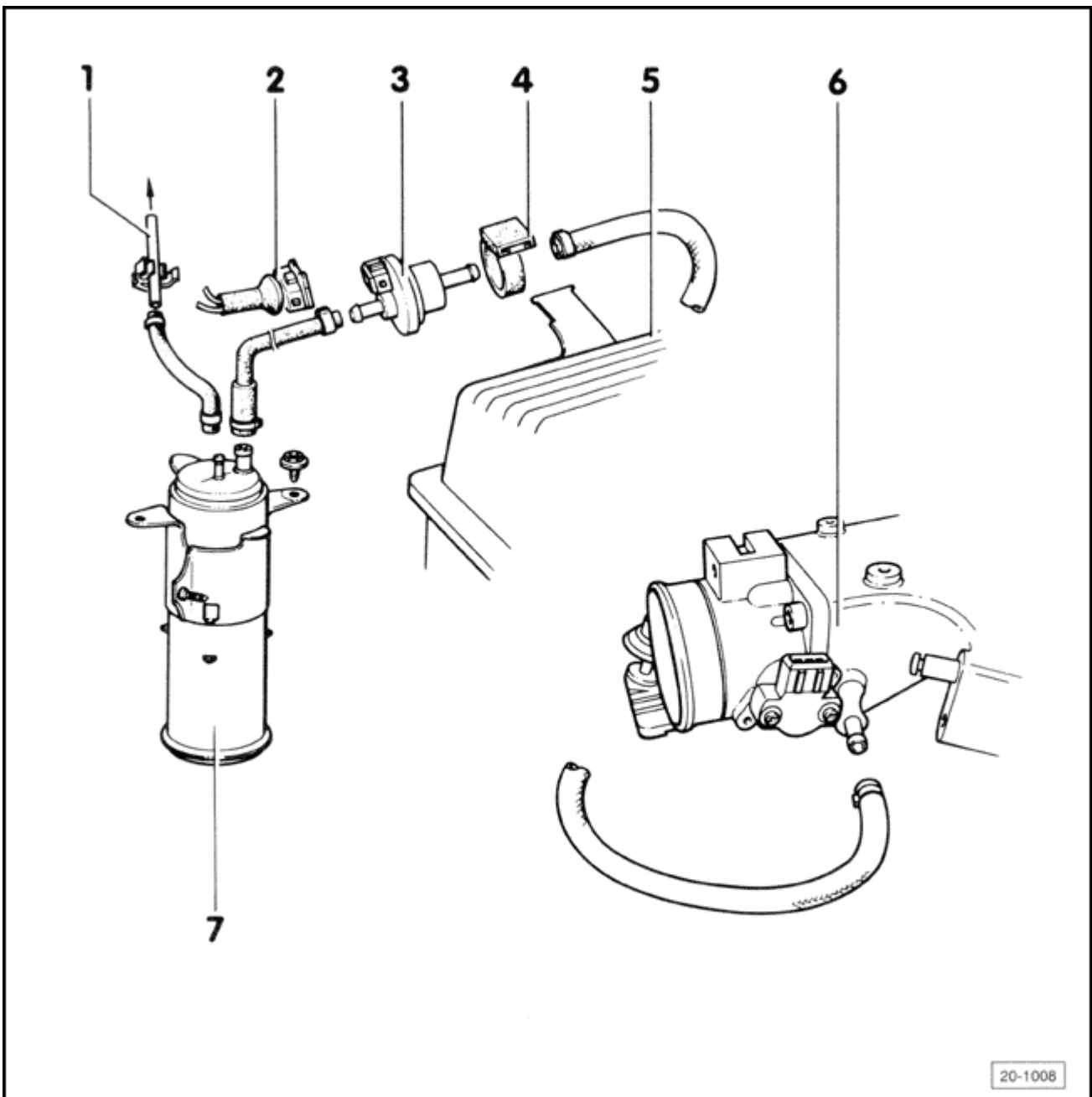

1 - Vent pipe to gravity valve

see [page, 20-18](#)

2 - Harness connector

3 - EVAP solenoid valve 1 (N80)

- with ignition switched off, valve to throttle valve housing open
- the valve is activated from Motronic engine control module when engine warm (pulsed)
- checking, see [Repair Group 01 \(Fuel Injection and Ignition\)](#)

4 - Retaining clamp

5 - Air cleaner housing

6 - Throttle valve housing

7 - Carbon canister

- location: right front wheel housing
- removing, take off air filter housing completely