

Engine code - PG

Coolant

- [draining](#)
- [filling](#)
- [hydrometer, checking](#)
- [mixture ratios](#)

Pump

- [assembly](#)
- [pulleys](#)

Radiator

- [assembly](#)

Thermoswitch

- [checking](#)
- [switching temperature](#)

Engine code - AAA

Coolant

- [draining/filling](#)
- [hydrometer, checking](#)
- [mixture ratio](#)

Pump

- [assembly](#)
- [removing/installing](#)
- [auxiliary electric coolant pump, checking](#)
- [fan control modual location](#)

Radiator/fan

- [assembly](#)
- [removing/installing](#)

Thermostat

- [assembly](#)

Volkswagen Corrado 1990 - 1994
General Engine
Engine - Cooling System (Page 19-2)

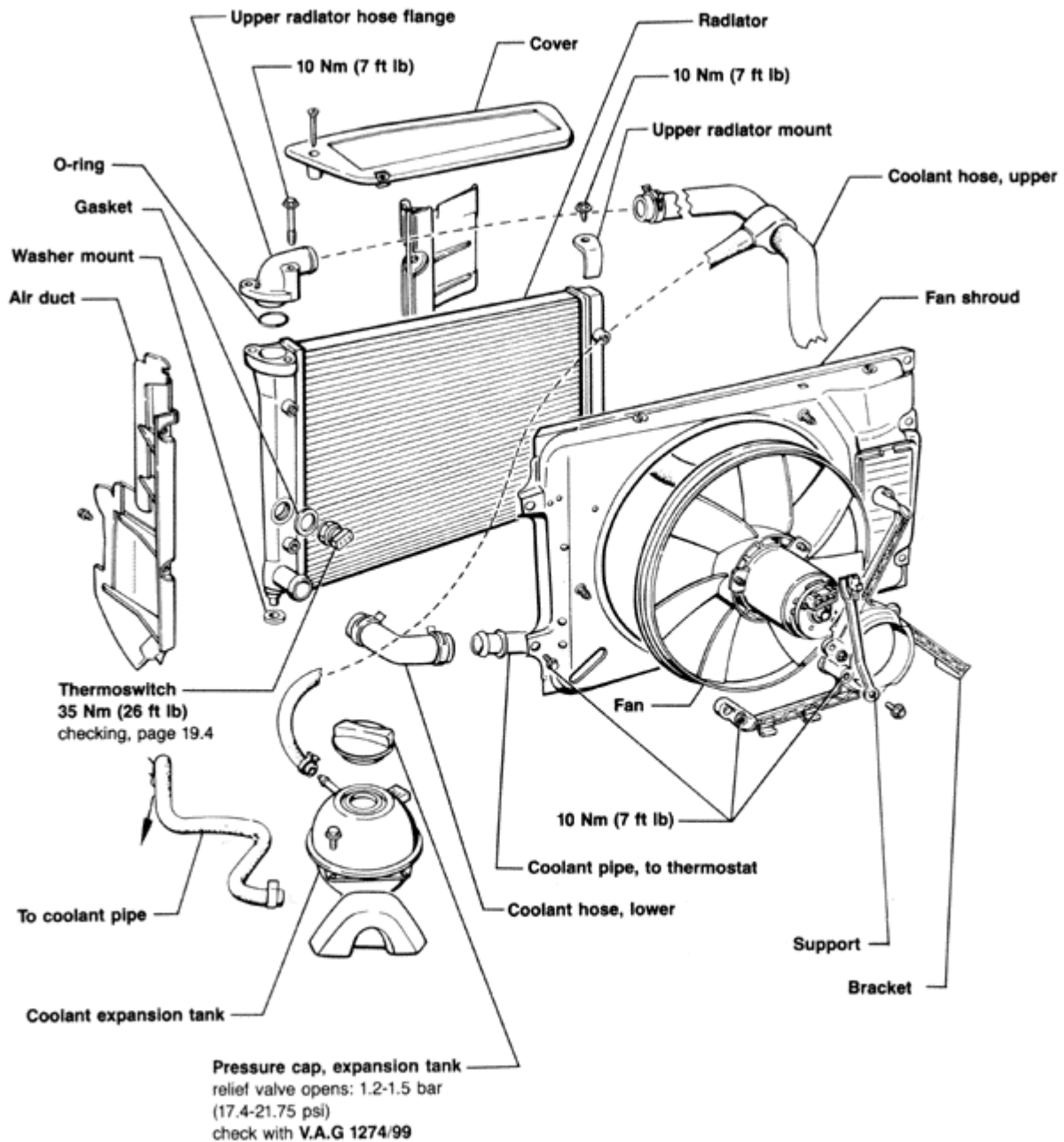

19-470

Notes

Ensure that no coolant hoses or lines touch the knock sensor. This could dampen the sensor and diminish the signal.

Volkswagen Corrado 1990 - 1994
 General Engine
 Engine - Cooling System (Page 19-3)

CAUTION!

Coolant antifreeze must not be reused when replacing engine, cylinder head, cylinder head gasket, radiator and heater core.

Notes

Always replace all gaskets and O-rings. All components shown can be removed/installed with the engine in vehicle.

During repairs, the original spring type hose clamps may be replaced by the screw type.

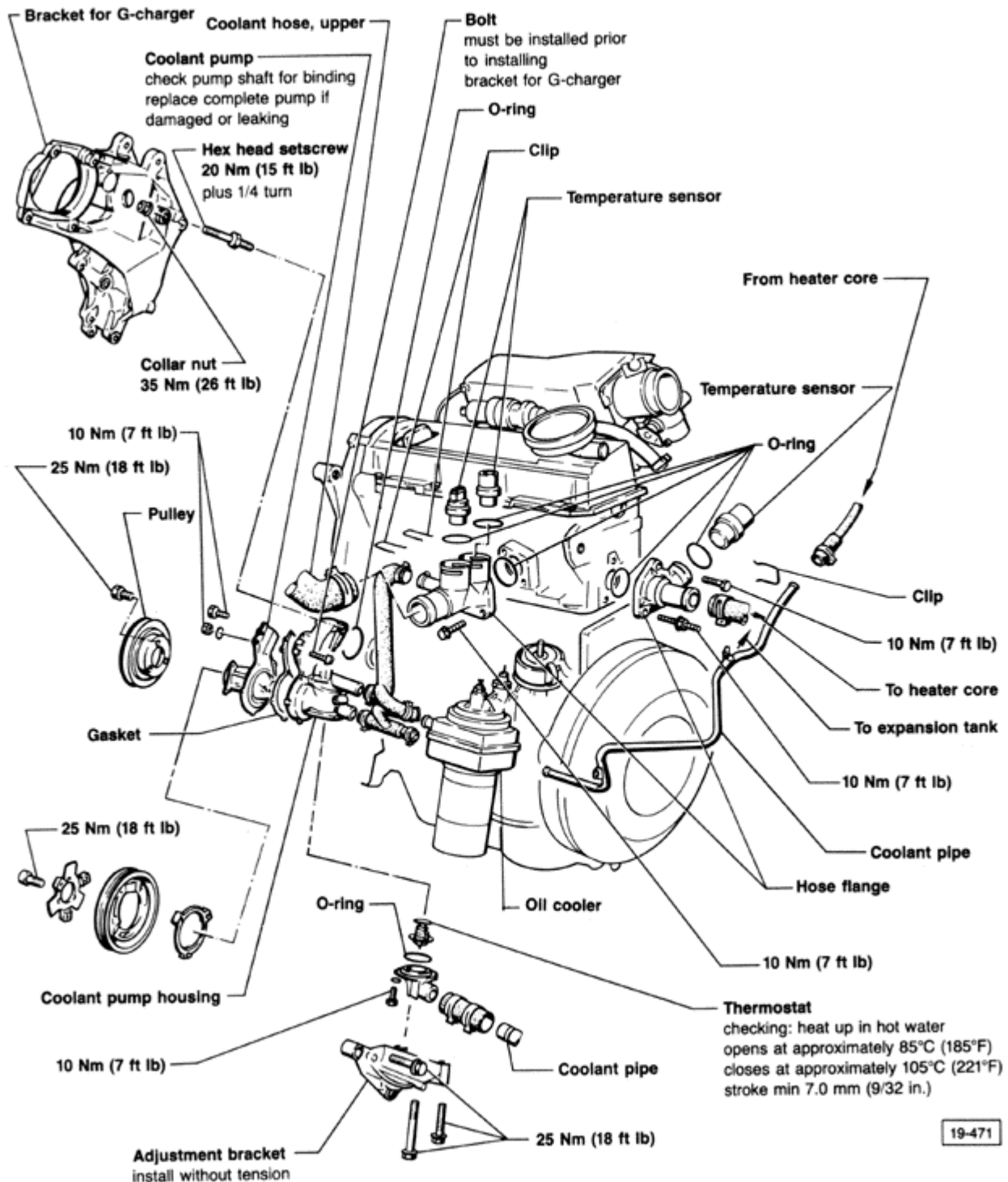

Notes

Ensure that no coolant hoses or lines touch the knock sensor. This could dampen the sensor and diminish the signal.

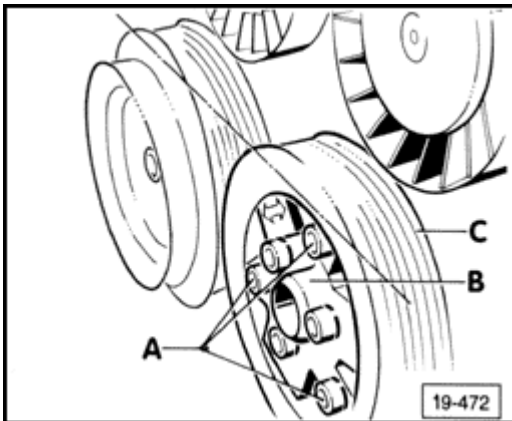

A

Fig. 1 Coolant pump pulley, adjusting

- loosen bolts **A**
- turn inner part **B** against pulley **C** until pulleys are aligned
- re-tighten bolts **A**

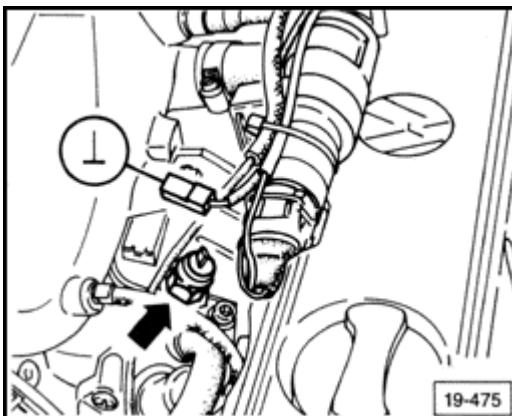

A

Fig. 2 Thermostatic switch, radiator fan after-run

Thermostatic switch comes on: approximately 90° C (194° F)

Thermostatic switch cuts off: approximately 80° C (176° F)

Thermostatic switch, checking

- turn ignition key on/off
- disconnect thermostatic switch and touch to ground
 - fan must come on

If **NO** , replace switch

Thermostatic switch, specifications

Switching temperatures		
Switch	On	Off

Low speed	92-97 ° C (198-207 ° F)	84-91 ° C (183-196 ° F)
High speed	99-105 ° C (210-221 ° F)	91-98 ° C (196-208 ° F)

Cooling system, draining

CAUTION!

Coolant/antifreeze must not be reused when replacing engine, cylinder head, cylinder head gasket, radiator and heater core.

The cooling systems of **all** Volkswagen vehicles are filled at the factory with a mixture of water and an antifreeze solution (**G 11**) with corrosion inhibitors. This coolant mixture should be used year-round.

Phosphate-free anti-freeze prevents frost and corrosion damage, the formation of chalk and in addition, it raises the boiling point of water. Due to the higher boiling point the coolant is an aid to operational efficiency, when the engine is operating under full load, particularly in tropical climates.

When replacing coolant/antifreeze solution in all Volkswagen models, all model years, use phosphate-free coolant/antifreeze **ZVW237 102** .

Recommended mixtures

Frost Protection to:	G 11	Water
-13 ° F/-25 ° C	2.3L (2.4 qt.)	3.3L (3.59 qt.)
-31 ° F/-35 ° C*	2.75L (2.9 qt.)	2.75L (2.9 qt.)

* for countries with cold climate

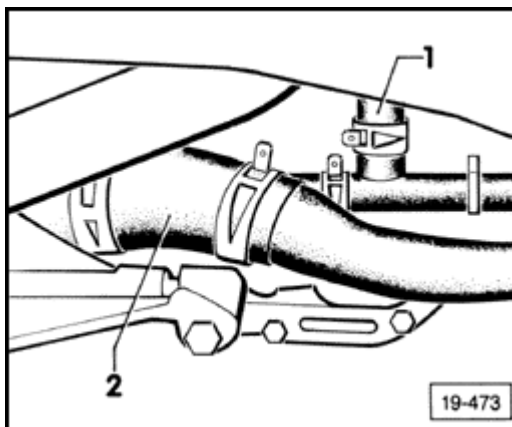

A

- open cap on coolant expansion tank
- drain coolant through loosening either coolant hose **1** or **2**

Cooling system, filling

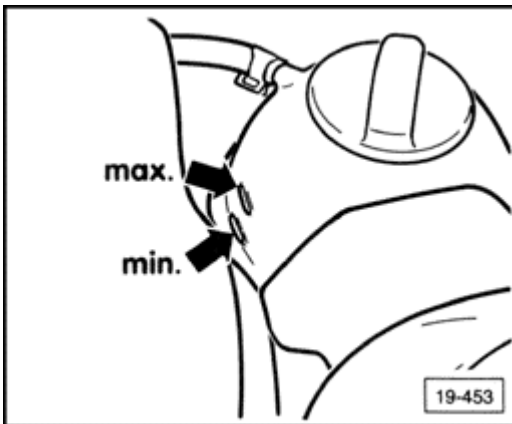

A

- retighten loosened coolant hoses
- fill with coolant up to **max** marking on coolant expansion tank
- close coolant expansion tank
- let engine run until radiator fan comes on
- check coolant level. If necessary, top off up to the marking. With engine at operating temperature, coolant level should be at **max** mark. With the engine cold, the coolant level should be between the **min** and **max** marking.

Antifreeze hydrometer, checking

Calibration of hydrometer must be checked frequently to ensure accuracy.

- mix a 50/50 mixture of antifreeze and water together in a small container
- hydrometer should read -35°C (-30°F)
 - if not, put a mark (paint dot) to indicate where -35°C (-30°F) should be.

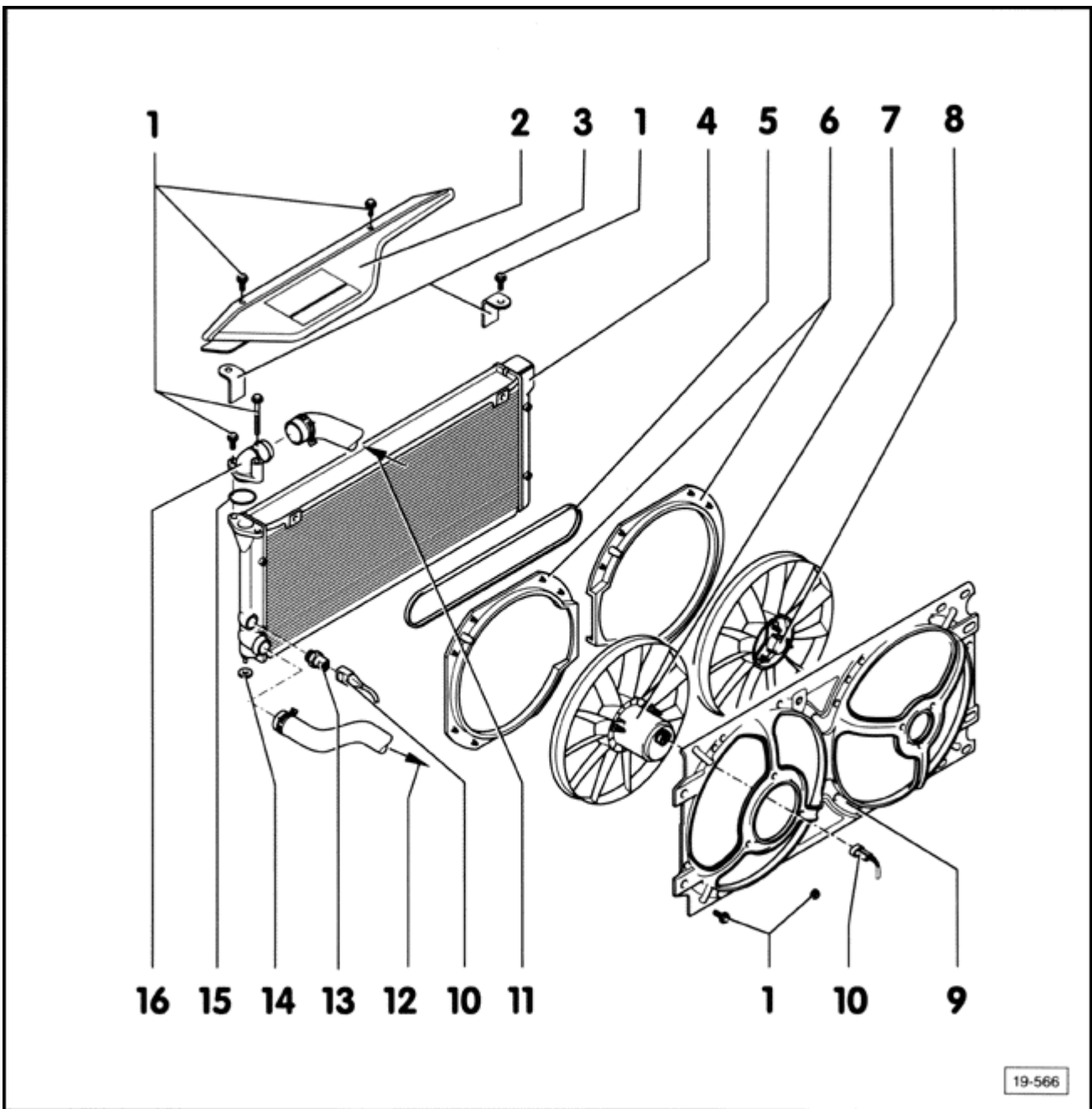

CAUTION!

Coolant/antifreeze must not be reused when replacing engine, cylinder head, cylinder head gasket, radiator and heater core.

WARNING!

DO NOT re-use any fasteners that are worn or deformed in normal use. Many fasteners are designed to be used only once and become unreliable and may fail when used a second time. This includes, but is not limited to, nuts, bolts, washers, self-locking nuts or bolts, circlips, cotter pins. Always follow recommendations given in this publication. For replacements always use new parts.

Notes

- always replace all gaskets and O-rings
- all components shown can be removed/installed with the engine in vehicle.

- during repairs, the original spring type hose clamps may be replaced by the screw type
- install spring clamps using pliers **Hazlet 798-5** or a commercial plier equivalent

1 - 10 Nm (7 ft lb)

2 - Cover

3 - Upper radiator mount

note installation position

Volkswagen Corrado 1990 - 1994

General Engine

Engine - Cooling System (Page 19-8)

4 - Radiator

- removing and installing, see [page 19-13](#)
- see replacement of coolant/antifreeze **CAUTION** on [page 19-7](#)

5 - V-belt

6 - Guide rings

- note installation position
- secured to fan shroud **9** with clips

7 - Fan (V7)

removing and installing, see [page 19-13](#)

8 - Additional fan for cooling

removing and installing, see [page 19-13](#)

9 - Fan shroud

note installation position

10 - Connector

11 - Coolant hose, upper

from upper connector on thermostat housing, see [page 19-9](#)

12 - Coolant hose, lower

to regulator on thermostat housing, see [page 19-9](#)

13 - Thermo-switch (F18) - 35 Nm (26 ft lb)

- for coolant fan
- switch temperatures:

1st stage:

on: 92-97° C (198-208° F)

off: 84-91° C (143-164° F)

2nd stage:

on: 99-105° C (178-189° F)

off: 91-98° C (164-176° F)

14 - Washer mount

15 - O-ring

replace

16 - Upper radiator hose flange

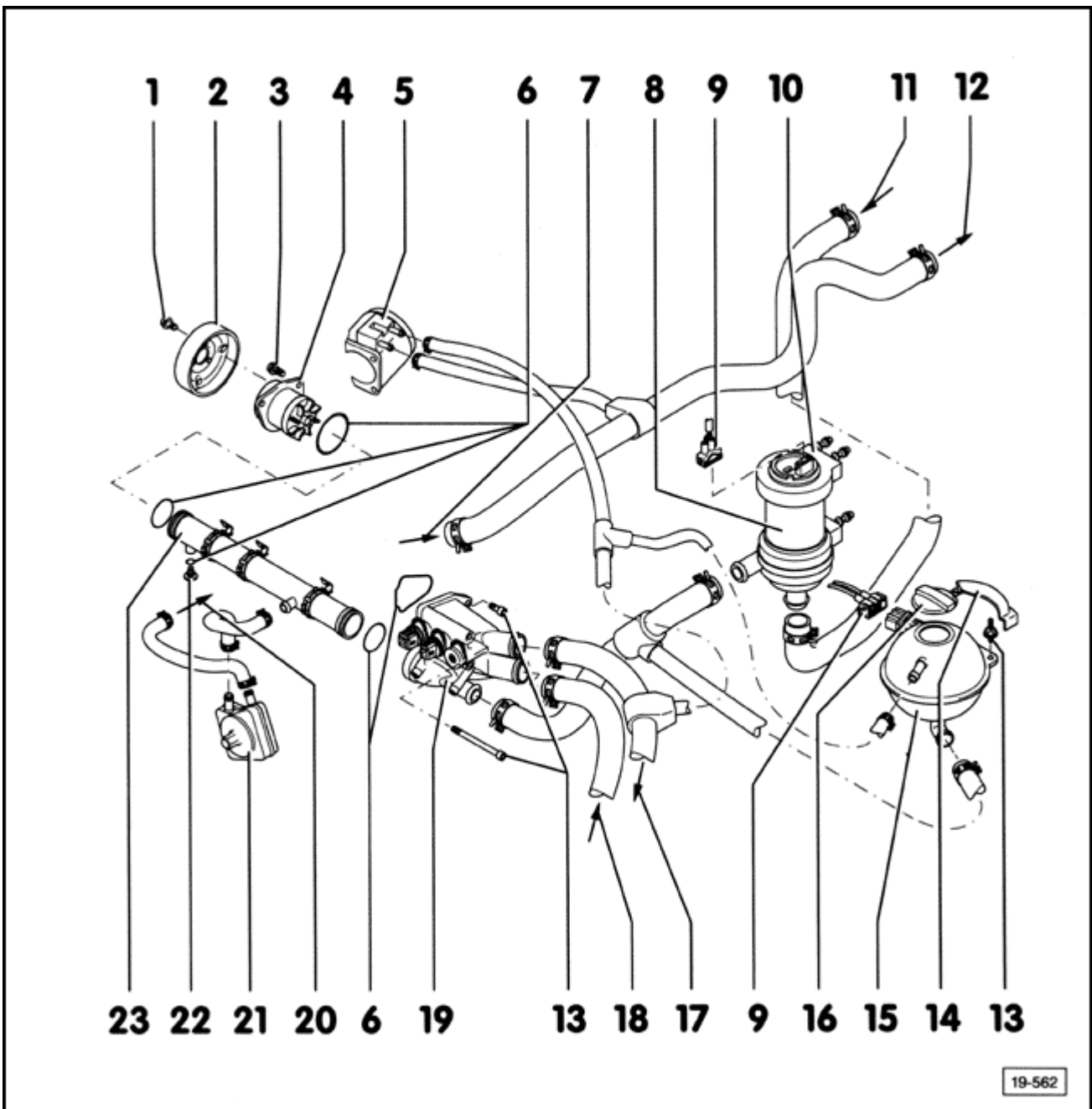

CAUTION!

Coolant/antifreeze must not be reused when replacing engine, cylinder head, cylinder head gasket, radiator and heater core.

Notes

- always replace all gasket and O-rings
- all components shown can be removed/installed with the engine in vehicle
- during repairs, the original spring type hose clamps may be replaced by the screw type
- install spring clamps using pliers **Hazlet 798-5** or a commercial plier equivalent

1 - 25 Nm (18 ft lb)

use coolant pump wrench **VAG 1590** to loosen/tighten

2 - V-belt pulley

3 - 20 Nm (15 ft lb)

4 - Coolant pump

removing and installing, see [page 19-14](#)

5 - Throttle body housing

6 - O-ring

replace

7 - From cylinder head

Volkswagen Corrado 1990 - 1994
General Engine
Engine - Cooling System (Page 19-10)

8 - Auxiliary electric coolant pump (V51)

checking, [page 19-19](#)

9 - Connector

10 - Rubber retainer

11 - From heat exchanger

12 - To heat exchanger

13 - 10 Nm (7 ft lb)

14 - Trim

15 - Coolant expansion tank

with coolant low level switch

16 - Pressure cap

- check with cooling system tester **VAG 1274** , and adapters **VAG 1274/3, VAG 1274/4**
- relief valve opens: 1.2-1.5 bar (17.4-21.8 psi)

17 - Coolant hose, upper

to radiator, upper, see [page 19-7](#)

18 - Coolant hose, lower

from radiator, lower, see [page 19-7](#)

19 - Thermostat housing

disassembling/assembling, see [page 19-17](#)

20 - To cylinder block

21 - Oil cooler

22 - Drain plug

draining and refilling coolant, see [page 19-11](#)

23 - Coolant tube

Cooling system, draining/filling

Draining

CAUTION!

Coolant/antifreeze must not be reused when replacing engine, cylinder head, cylinder head gasket, radiator and heater core.

- remove cap from expansion tank
- remove drain plug from coolant pipe, see [page 19-9](#)

Notes

Direct the coolant when draining by slightly twisting the coolant pipe.

Filling

The cooling systems of **all** Volkswagen vehicles are filled at the factory with a mixture of water and an antifreeze solution (**G 11**) with corrosion inhibitors. This coolant mixture should be used year-round.

Phosphate-free anti-freeze prevents frost and corrosion damage, the formation of chalk, and in addition, it raises the boiling point of water. Due to the higher boiling point the coolant is an aid to operational efficiency, when the engine is operating under full load, particularly in tropical climates.

When replacing coolant/antifreeze solution in all Volkswagen models, all model years, use phosphate-free coolant/antifreeze **ZVW 237-104** .

Recommended mixtures

Frost protection to:	G 11	Water
-25 ° C (-13 ° F)	3.5L (3.7 qt.)	6.5L (6.8 qt.)
-35 ° C (-31 ° F)*	5.0L (5.3 qt.)	5.0L (5.3 qt.)

* for countries **with** cold climates

Volkswagen Corrado 1990 - 1994

General Engine

Engine - Cooling System (Page 19-12)

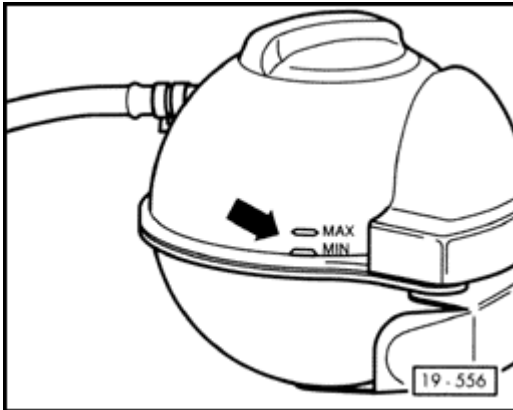

- install coolant pipe drain plug
- slowly fill coolant expansion tank with coolant up to **max** marking (**arrow**)
- install coolant expansion tank cap
- run engine until cooling fan (**V7**) comes on
- check coolant level. If necessary, top off up to the marking. With engine at operating temperature, coolant level should be slightly above **max** mark. With engine cold, the coolant level should be between the **min** and **max** marks.

Radiator/fan, removing/installing

Removing

CAUTION!

Wait at least 20 seconds after switching off ignition before disconnecting battery. This will allow the platinum hot-wire in Air Mass Sensor (G70) to burn itself clean.

CAUTION!

Always switch off ignition when disconnecting/reconnecting battery, or any part of Motronic ignition wiring system to prevent damage to Motronic control unit (J 220)

CAUTION!

Always obtain security code before disconnecting battery ground strap.

- switch off ignition
- disconnect and remove battery
- drain coolant, see [page 19-11](#)
- disconnect coolant hoses from radiator
- disconnect thermo-switch, and coolant fan
- unscrew radiator mounting bolts (retaining bracket on lock support)
- remove front bumper, see [Repair Group 63](#)
- remove lock support, see [Repair Group 50](#)
- remove radiator from the top

Vehicle with A/C

CAUTION!

Do not kink or disconnect A/C refrigerant lines.

If A/C refrigerant system is opened or requires service, refer to Repair Group 87 for **CAUTIONS**, **WARNINGS** and procedures.

- unscrew retaining clamps for freon lines
- separate A/C condenser from radiator, and pull forward as far as possible
- remove radiator from the top between condenser and engine

Installing

Reinstall all components in reverse order, noting the following:

CAUTION!

Coolant/antifreeze must not be reused when replacing engine, cylinder head, cylinder head gasket, radiator and heater core.

- refill coolant, see [page 19-11](#)
- check headlight adjustment, adjust if necessary

Coolant pump, removing/installing

Removing

CAUTION!

Wait at least 20 seconds after switching off ignition before disconnecting battery. This will allow the platinum hot-wire in Air Mass Sensor (G70) to burn itself clean.

CAUTION!

Always switch off ignition when disconnecting/reconnecting battery, or any part of Motronic ignition wiring system to prevent damage to Motronic control unit (J 220).

CAUTION!

Always obtain security code before disconnecting battery ground strap.

- switch off ignition
- disconnect battery ground strap
- drain coolant, see [page 19-11](#)
- disconnect front exhaust pipe at flange to catalyst, see [Repair Group 26](#)
 - replace fastening nuts
- remove poly ribbed belt, see [Repair Group 13](#)

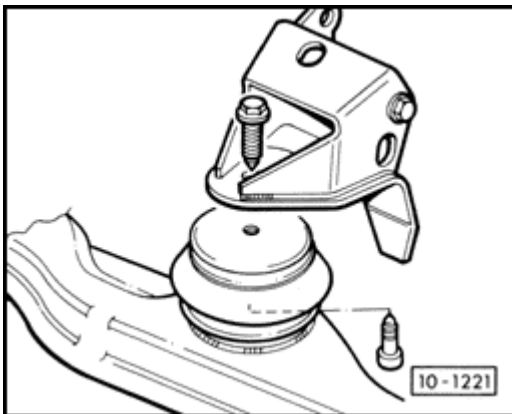

- disconnect engine with bracket from front engine rubber mount, from top (as shown)

Volkswagen Corrado 1990 - 1994
General Engine
Engine - Cooling System (Page 19-15)

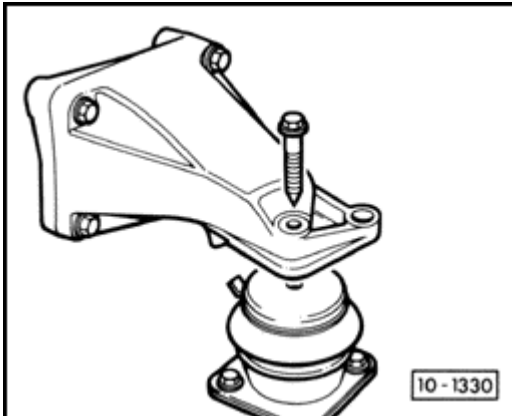

- disconnect engine with bracket from rear engine rubber mount (as shown)

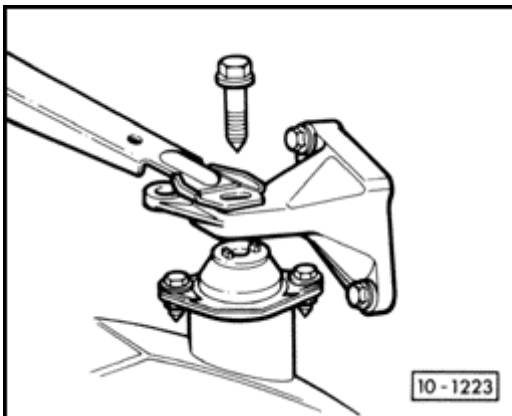

- unscrew transmission with bracket on rear transmission rubber mount (as shown)

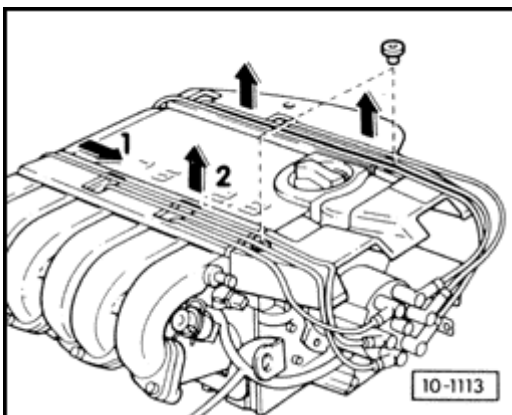

- remove ignition cable guide

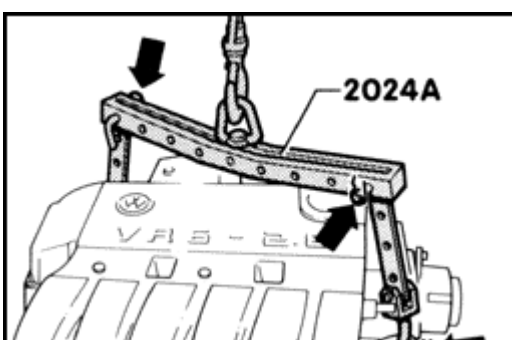

CAUTION!

Use cotter pins on hooks and holding pins (arrows) to secure engine sling 2024A .

- attach engine sling, as shown and take weight with crane

Pulley side (**left arrow**)

fourth hole in vertical bar at position **1**

Volkswagen Corrado 1990 - 1994

General Engine

Engine - Cooling System (Page 19-16)

Flywheel side (**right arrow**)

fourth hole in vertical bar at position **8**

The positions marked 1-4 on the bar must be towards the pulley side. The holes in the vertical bar are counted **upwards** from the hook.

- lift engine with transmission sufficiently to gain access to coolant pump
- using water pump wrench **VAG 1590** , remove coolant pump pulley
- unscrew coolant pump
- remove pump by pushing engine/transmission slightly by hand to the left for clearance

Installing

Reinstall all components in reverse order, noting the following:

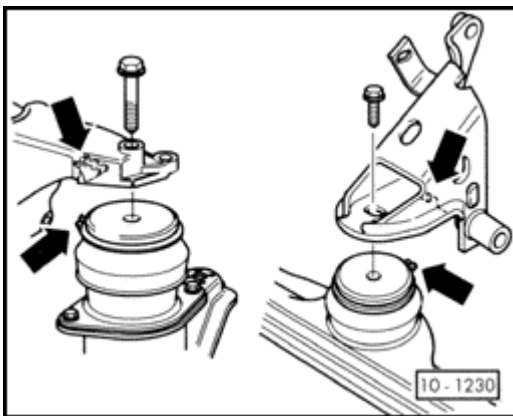

- when installing engine brackets ensure that the recess on the right rear engine bracket and the front engine bracket fits into the mounting tab of the bonded rubber bushings (**arrow**)
- hand tighten engine and transmission carrier bolts approximately 5 - 6 turns
- lightly rock or shake engine to adjust position
- fully tighten engine, then transmission carrier bolts
- reinstall poly-ribbed belt, see [Repair Group 13](#)
- refill coolant, see [page 19-11](#)

Tightening torques

Pulley to pump	25 Nm (18 ft lb)
Coolant pump to cylinder block	20 Nm (15 ft lb)
Exhaust pipe to catalytic convertor	25 Nm (18 ft lb)

Engine/transmission carrier, brackets, see [Repair Group 10](#)

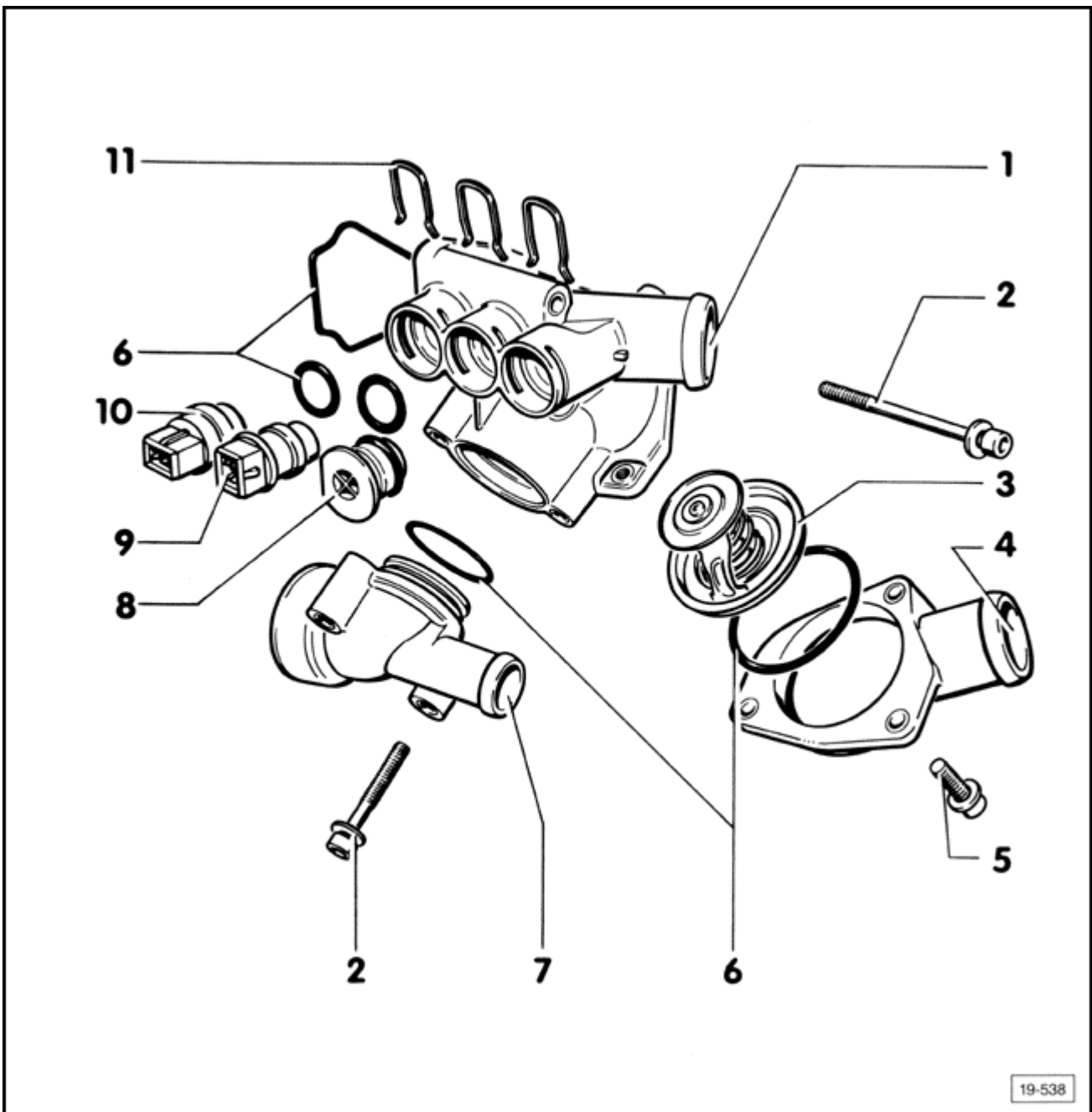

19-538

1 - Thermostat housing

with hose connection to upper radiator, see [page 19-8](#)

2 - (7 ft lb)

3 - 3- Thermostat

- checking: heat thermostat in water
 - opens at approximately 80° C (176° F)
 - closes at approximately 105° C (221° F)
 - stroke min. 7.0mm (9/32 in.)

4 - Cover

with hose connection from lower radiator, see [page 19-9](#)

5 - 10 Nm(7 ft lb)

6 - O-ring

replace

7 - Cover

with hose connection to pump for coolant run-on, see [page 19-9](#)

8 - Plug

- for vehicles without air conditioning
- plug is replaced with temperature sender for vehicles with air conditioning

9 - Temperature sender switch (G2/F87)

- yellow
- 4-point
- for coolant run-on
- checking, see [page 19-19](#)
- switch temperatures:
 - on:** 101-107° C (214-225° F)
 - off:** 94-100° C (201-212° F)

10 - Sender for coolant temperature (G62)

- blue
- 2-point
- for motronic
- checking, see [Repair Group 01 \(Fuel Injection and Ignition\)](#)

11 - Mounting clip

- ensure secure fit

Auxiliary electric coolant pump (V51), radiator fan (V7) run-on, checking

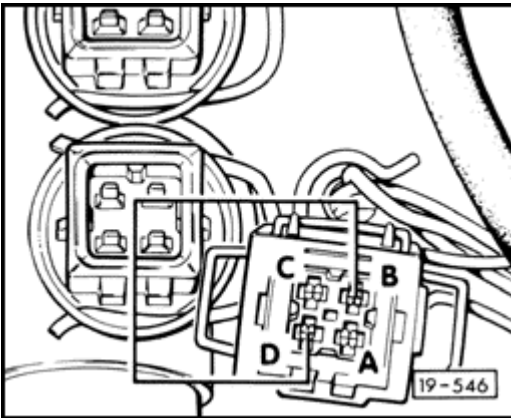

- turn ignition key on/off
- disconnect 4- point connector from temperature sender switch (**G2/F87**)
- bridge contacts **B, D** (brown/red and brown wire) using Connector Test Kit **VAG 1594**
 - radiator fan (**V7**), auxiliary coolant pump (**V51**) must come on

If **NO** , check with **VAG 1466** or equivalent.

Coolant fan control module, location/terminal identification

Location

The coolant fan control module is located in the engine compartment, on the left.

Connector terminal identification

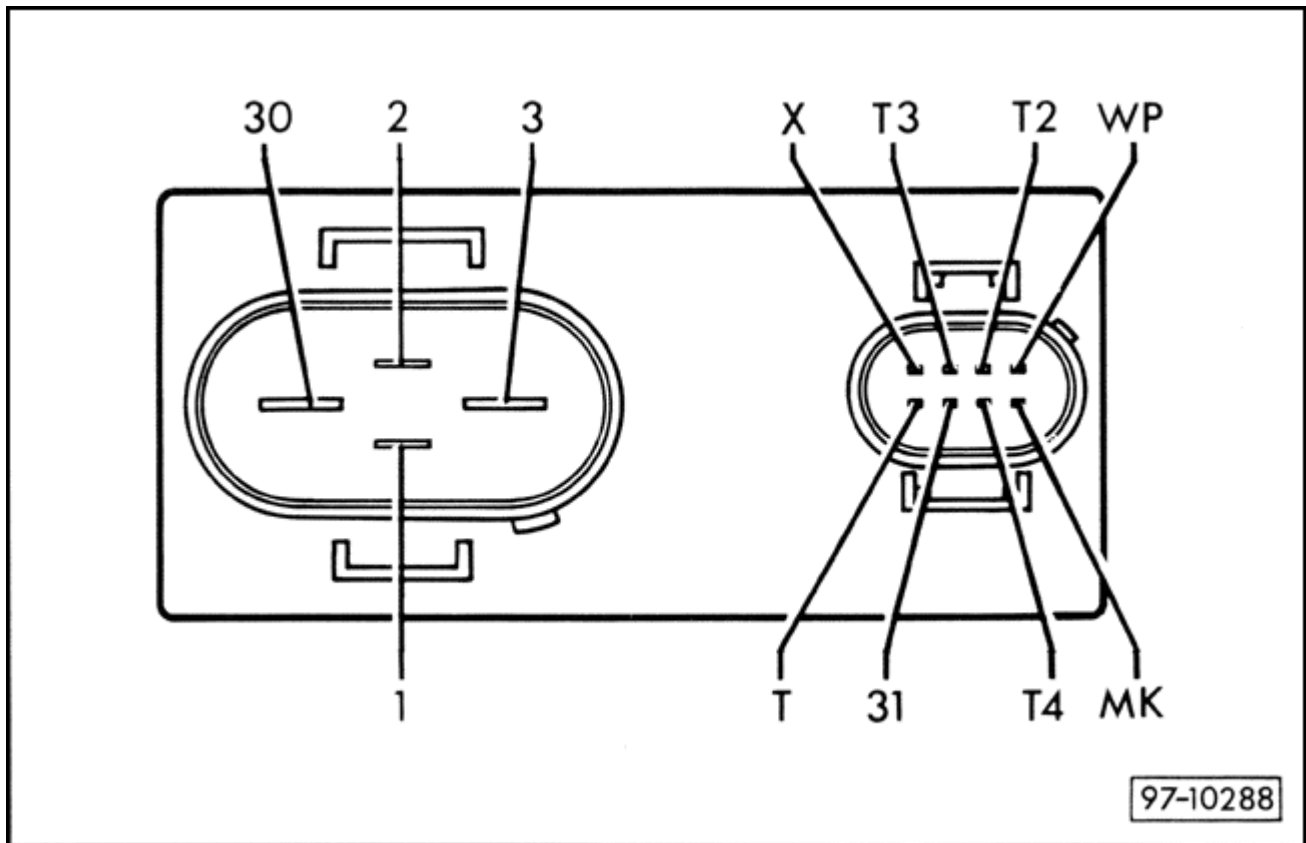

T 4/1 = 3	T 8e/1 = WP	T 8e/5 = MK
T 4/2 = 2	T 8e/2 = T2	T 8e/6 = T4
T 4/3 = 1	T 8e/3 = T3	T 8e/7 = 31
T 4/4 = 30	T 8e/4 = X	T 8e/8 = T

Notes

See wiring diagram for wire routing to **T 4** and **T 8** connectors. Always refer to appropriate wiring diagram when performing any electrical tests or repairs.