

1994 Volkswagen Corrado SLC

2.8L VR6

2.8L VR6

1994-98 ENGINES Volkswagen 2.8L 6-Cylinder

ENGINE IDENTIFICATION

NOTE: For engine repair procedures not covered in this article, see **ENGINE OVERHAUL PROCEDURES - GENERAL INFORMATION** article in the **GENERAL INFORMATION** section.

Engine identification number is stamped on a machined pad, on front of the cylinder block. See **Fig. 1** . The engine code is also listed on a sticker attached to the pulley side of the valve cover and the vehicle identification sticker located in the luggage compartment.

ENGINE CODES

Application	Code
2.8L VR6	AAA

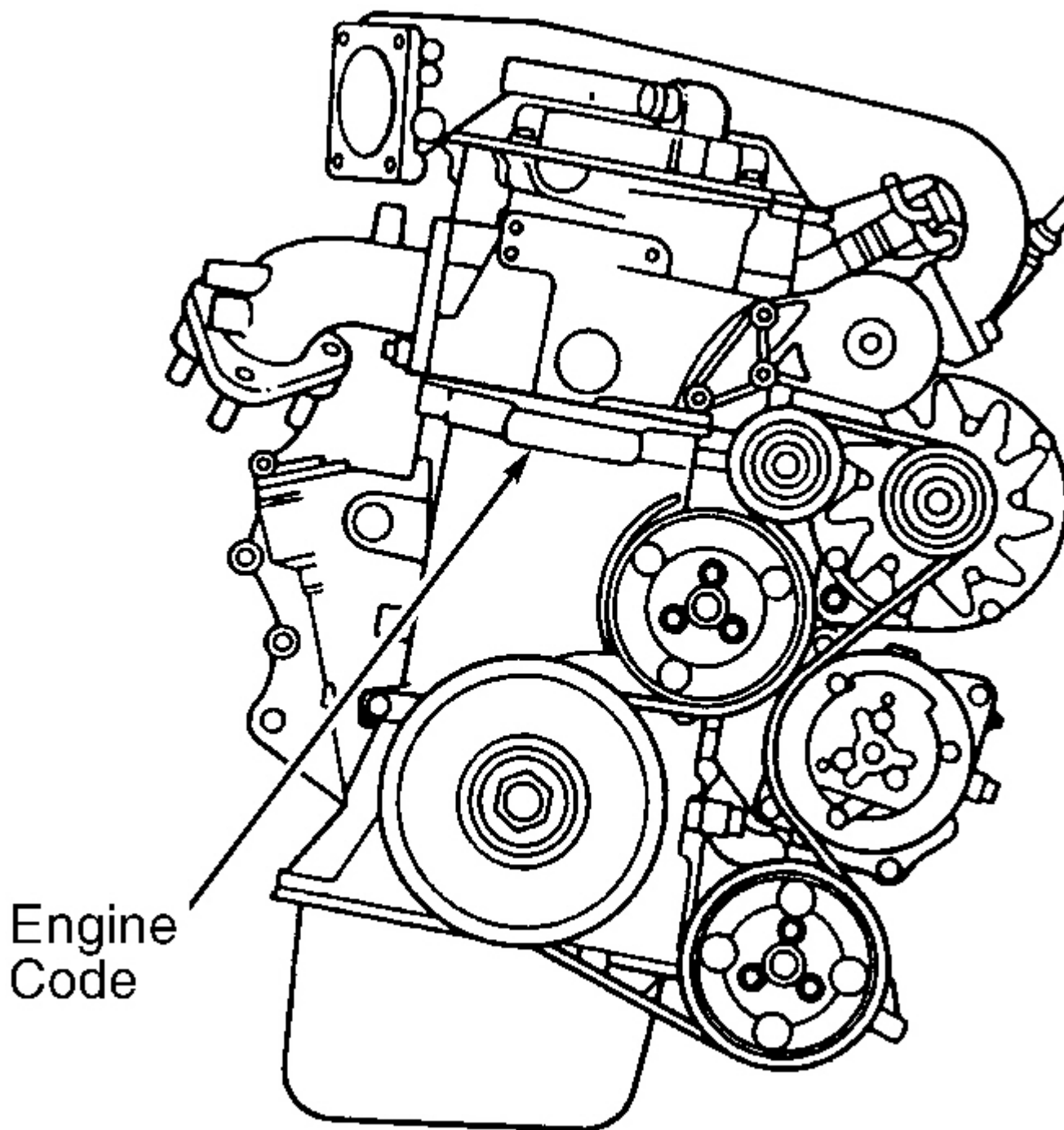

G93H83102

Fig. 1: Locating Engine Identification Number
Courtesy of VOLKSWAGEN UNITED STATES, INC.

ADJUSTMENTS

VALVE CLEARANCE

Engine is equipped with hydraulic lifters. Adjustment is not necessary.

REMOVAL & INSTALLATION

CAUTION: Radio/cassette or radio/CD player is equipped with an anti-theft protection circuit. Whenever battery is disconnected, radio will go into anti-theft mode. When battery is reconnected, radio will display CODE, and will be inoperative until proper code number is entered. Obtain security code before disconnecting battery.

NOTE: For reassembly reference, label all electrical connectors, vacuum hoses and fuel lines before removal. Also place mating marks on other major assemblies before removal.

FUEL PRESSURE RELEASE

Remove fuel pump relay (lower right relay located in fuse/relay panel). Start engine and let idle until it stalls. Crank engine for an additional 5 seconds. Reinstall fuel pump relay.

ENGINE

NOTE: Engine is removed with transaxle attached.

Removal

1. Obtain radio code. Turn ignition off and wait 20 seconds. Disconnect negative battery cable. Remove air cleaner assembly. Install 8-mm bolt in belt tensioner hole and remove service belt. See **Fig. 2**.
2. On manual transmission models, disconnect clutch slave cylinder. On all models, remove power steering pump and attach to body. DO NOT disconnect power steering hoses. Remove radiator, front lock support and front bumper. Drain cooling system. Disconnect cooling fan and thermostat.

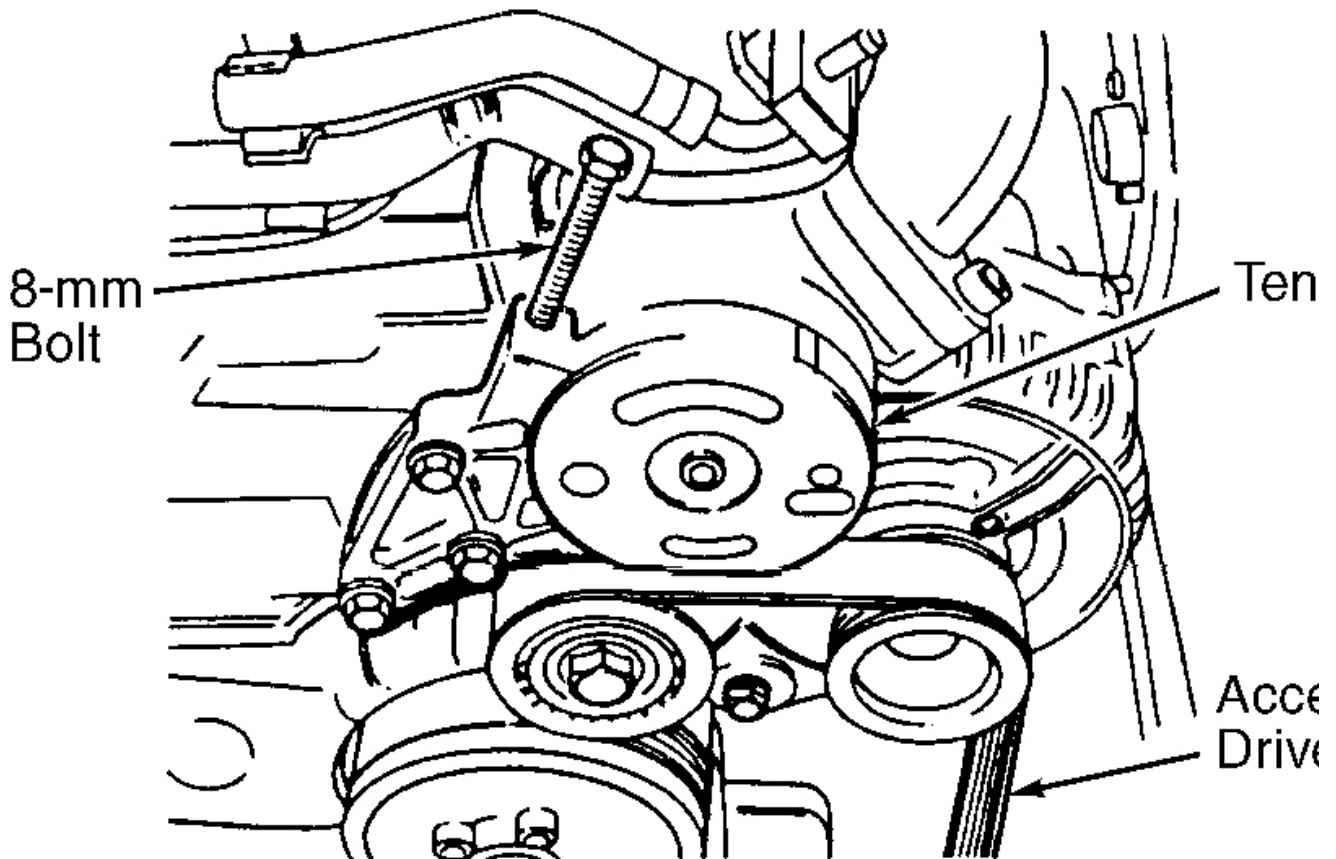

G93J83104

Fig. 2: Releasing Accessory Drive Belt Tensioner
 Courtesy of VOLKSWAGEN UNITED STATES, INC.

3. Label and disconnect all electrical wiring, control cables, coolant hoses and vacuum hoses from engine/transaxle assembly. Disconnect throttle, cruise and kickdown linkage (if equipped). Remove air duct from intake manifold.
4. Disconnect drive axles from transaxle. See AXLE SHAFTS - FRONT article in DRIVE AXLES. Disconnect exhaust pipe from exhaust manifold. Attach Engine Sling (2024A). See **Fig. 3**.
5. Disconnect left rear transaxle mount and right rear engine mount. Disconnect front engine mount. Release engine carrier. It may be necessary to pry spacer bracket from rubber bushings. Raise engine and transaxle out of vehicle.

Installation

To install, reverse removal procedure. Use NEW self-locking nuts and coolant. Ensure engine mounts are installed to original location. Align all engine supports with mount bushings before tightening mount bolts. Tighten bolts to specification. See **TORQUE SPECIFICATIONS**.

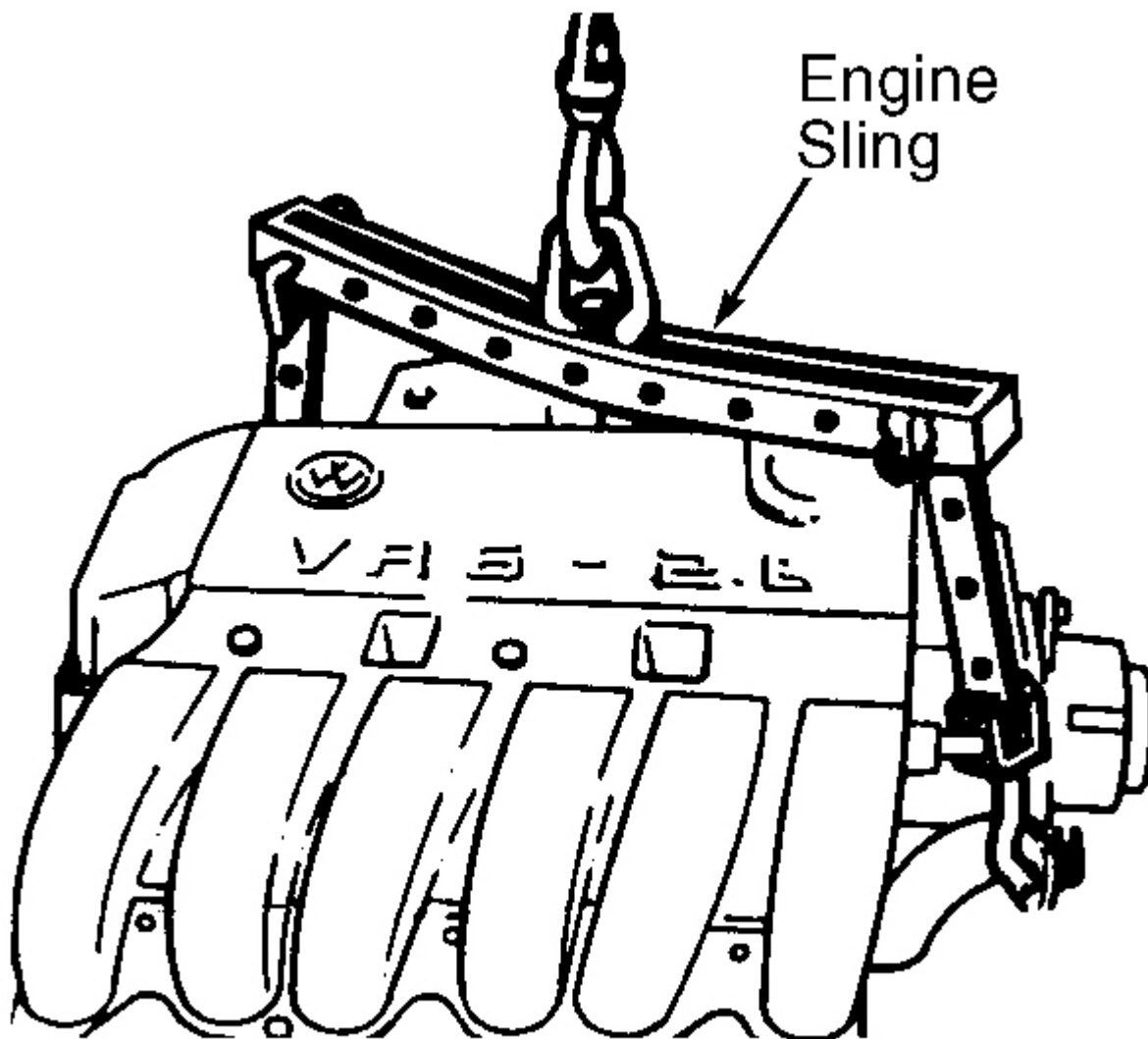

G93A83105

Fig. 3: Attaching Engine Sling

Courtesy of VOLKSWAGEN UNITED STATES, INC.

INTAKE & EXHAUST MANIFOLD

Removal and installation procedure is not available from manufacturer. See **TORQUE SPECIFICATIONS**.

CYLINDER HEAD

Removal

1. Remove upper engine cover. Remove wire guide. Remove right rear support between upper intake manifold and cylinder head. Remove fuel line bracket, flame trap coil and circlip. Remove wire brackets. Remove valve cover and gasket. See **Fig. 4**.

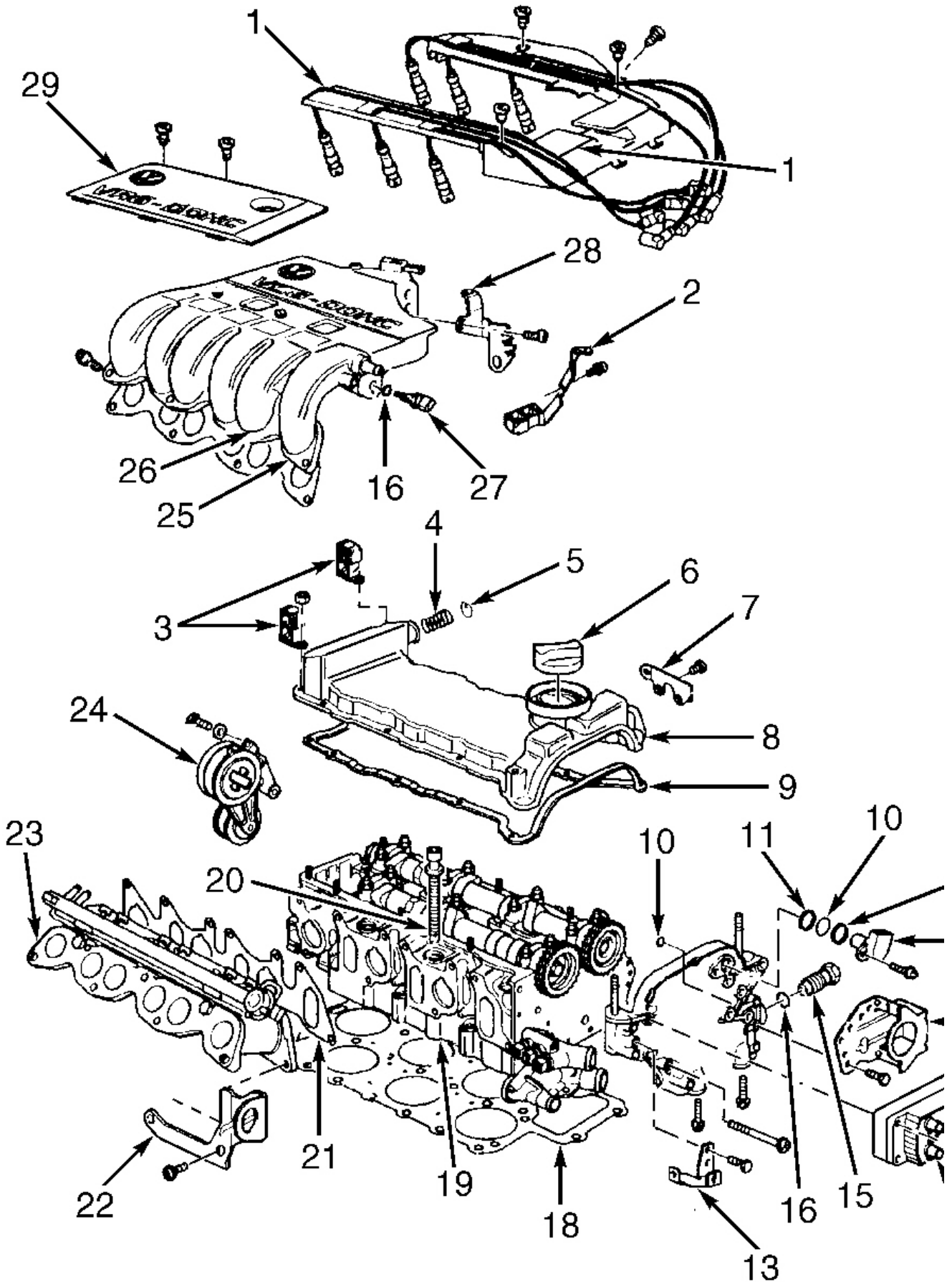

1. Wire Guide

2. Right Door Support

16. Seal

17. Camshaft Sprocket Cap

Fig. 4: Identifying 2.8L VR6 Cylinder Head

Courtesy of VOLKSWAGEN UNITED STATES, INC.

- Remove camshaft position sensor, "O" ring and spacer ring. Remove bracket for 42-pin connector and water pump. Remove ignition coil, chain tensioner and seal. Remove camshaft sprocket cover. Remove cylinder head bolts in reverse order of installation. See **Fig. 6** . Replace cylinder head bolts after loosening or removing.

Inspection

Thoroughly clean all gasket mating surfaces. Check cylinder head for warpage. Maximum warpage is .004" (.10 mm). Check minimum cylinder head height and replace cylinder head (if necessary). See **CYLINDER HEAD** table under ENGINE SPECIFICATIONS.

NOTE: DO NOT reuse antifreeze after replacing cylinder block, cylinder head, head gasket, radiator and/or heater core.

Installation

- Remove sealer from the two 3-mm holes and replace with new sealer. See **Fig. 5** . Install gasket onto guide pins. Guide pins should be located near bolt hole No. 12 and No. 20. See **Fig. 6** .
- Install cylinder head onto cylinder block. Do not use any type of sealant. Install head bolts and tighten by hand. Tighten cylinder head bolts (in 4 steps) in sequence to specification. See **Fig. 6** . See **TORQUE SPECIFICATIONS** .

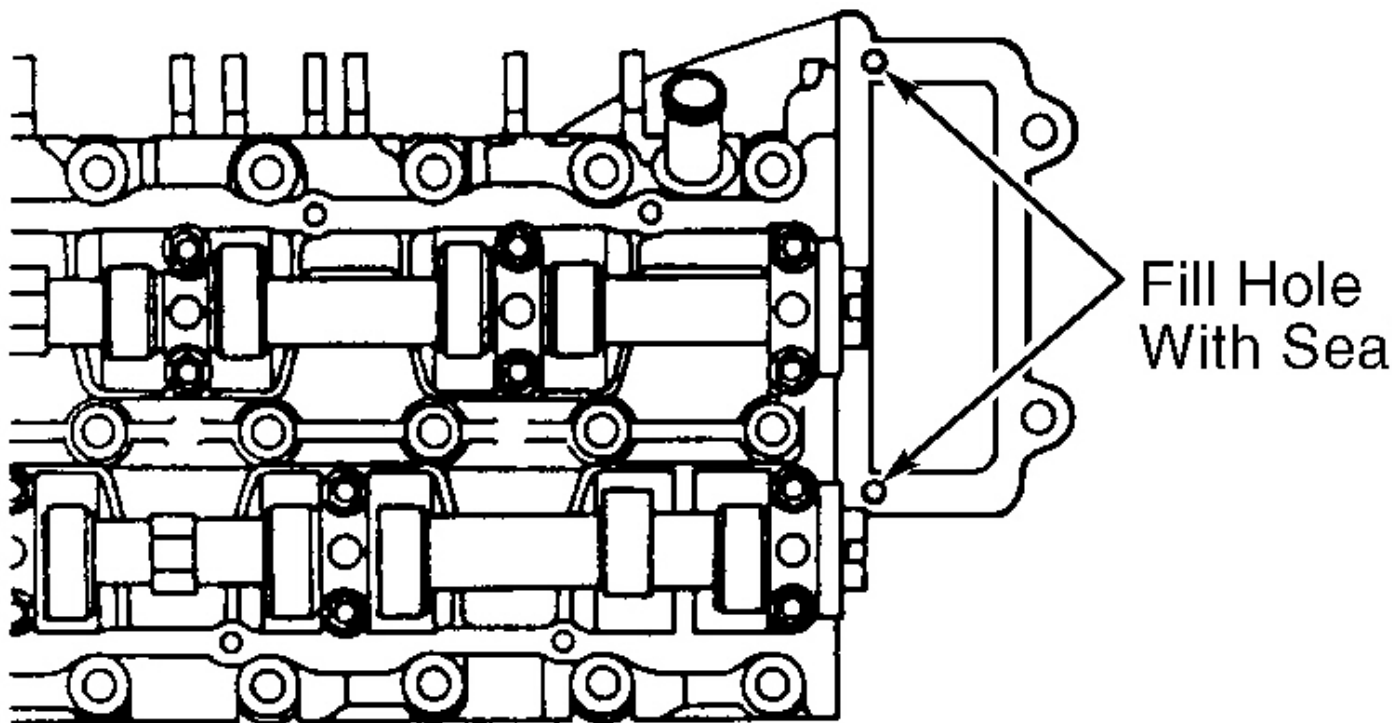

G93C83107

Fig. 5: Sealing Cylinder Head 3-mm Holes

Courtesy of VOLKSWAGEN UNITED STATES, INC.

← FRONT OF VEHICLE

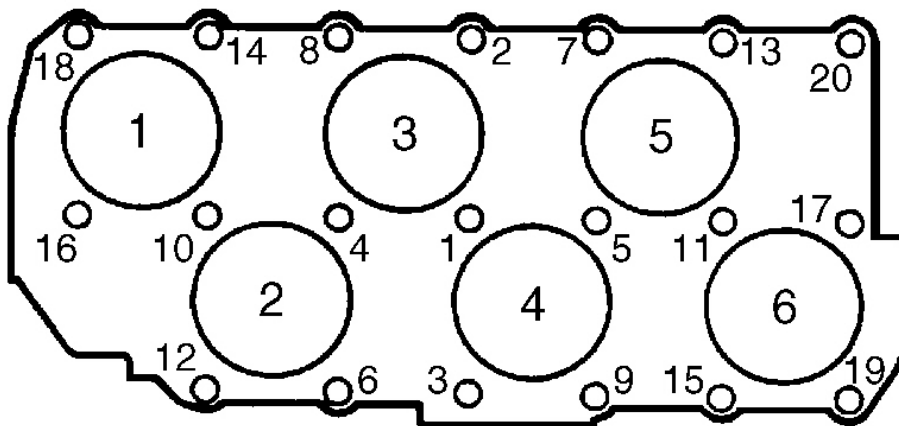

REMOVE IN REVERSE ORDER

G93D83108

Fig. 6: Cylinder Head Bolts Tightening Sequence
 Courtesy of VOLKSWAGEN UNITED STATES, INC.

CRANKSHAFT OIL SEAL

Removal

Install 8-mm bolt in belt tensioner hole and remove accessory drive belt. See **Fig. 2** . Remove vibration damper. Loosen inner section of Oil Seal Extractor (3203) about 3 turns (4 mm) and lock in position with knurled screw. Turn inner section of oil seal extractor until seal is removed.

Installation

Place guide Sleeve (3266/1) on crankshaft. Push oil seal over guide sleeve. Using Oil Seal Installer (3266) and vibration damper bolt, press oil seal in completely. See **Fig. 7** . Reverse removal procedure to complete installation.

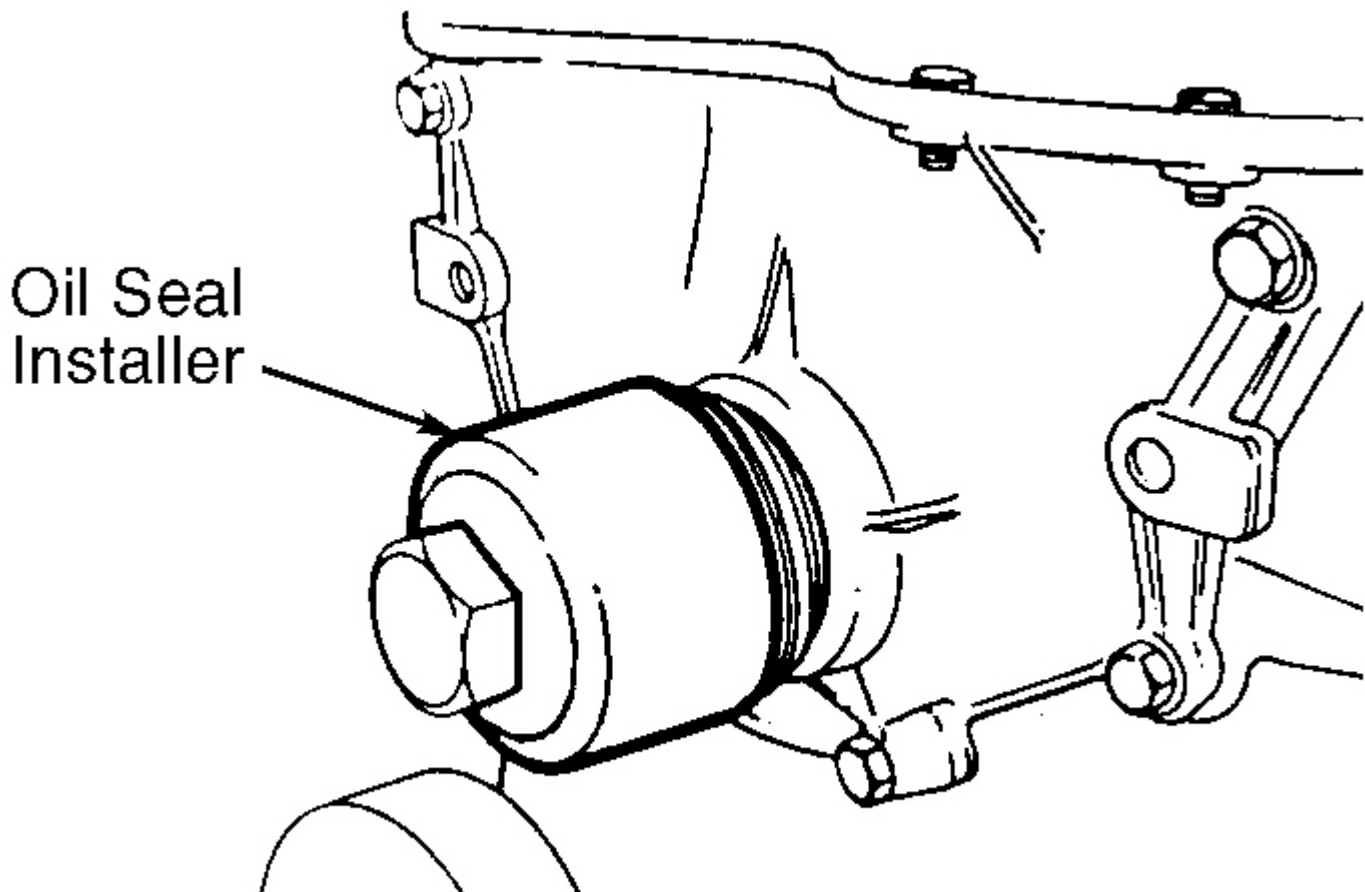

G93E83109

Fig. 7: Installing Crankshaft Oil Seal

Courtesy of VOLKSWAGEN UNITED STATES, INC.

TIMING CHAIN**Removal**

1. Removal and installation procedure is not available from manufacturer. Ensure crankshaft is aligned at TDC. Remove transaxle and bellhousing assembly. Remove torque converter or clutch assembly (as applicable). Remove valve cover. Remove camshaft sprocket cover and intermediate shaft cover. Match mark all components to ensure reassembly in original position.
2. Mark timing chains for direction of rotation. Align and install Camshaft Guide (3268) onto cylinder head bolts. See **Fig. 8** . Remove upper and lower chain tensioners. If necessary, remove intermediate sprocket and camshaft sprocket bolts. Remove the timing chain. See **Fig. 9** .

Camshaft
Guide

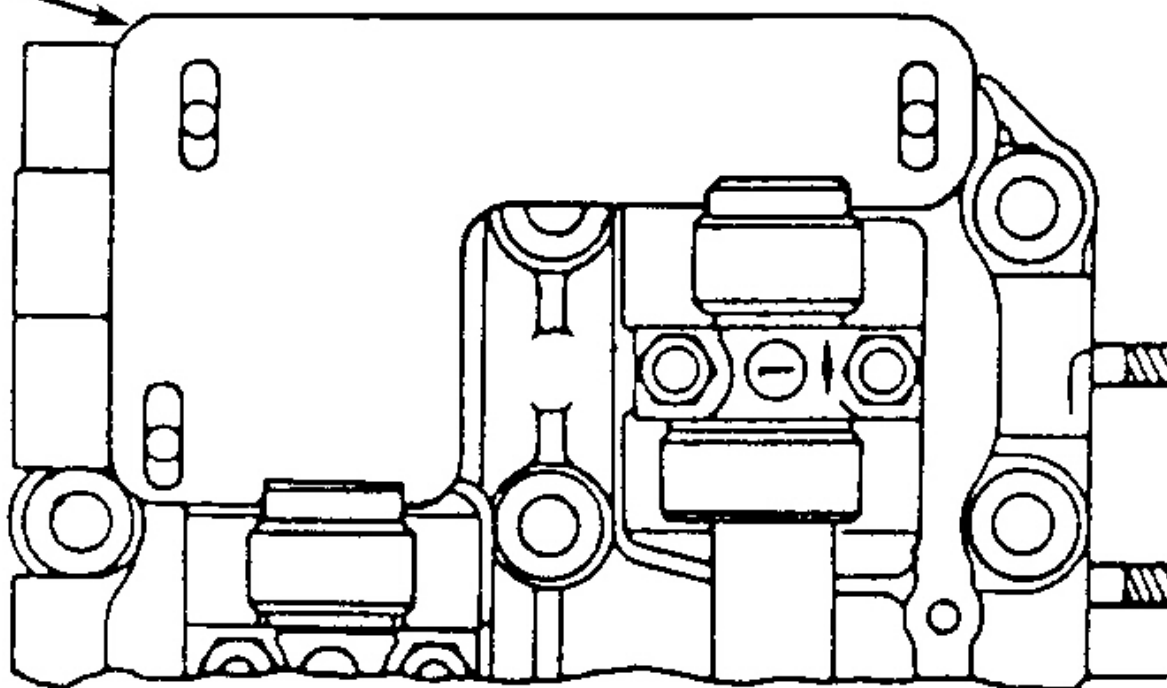

G93H83110

Fig. 8: Installing Camshaft Guide Onto Cylinder Head
Courtesy of VOLKSWAGEN UNITED STATES, INC.

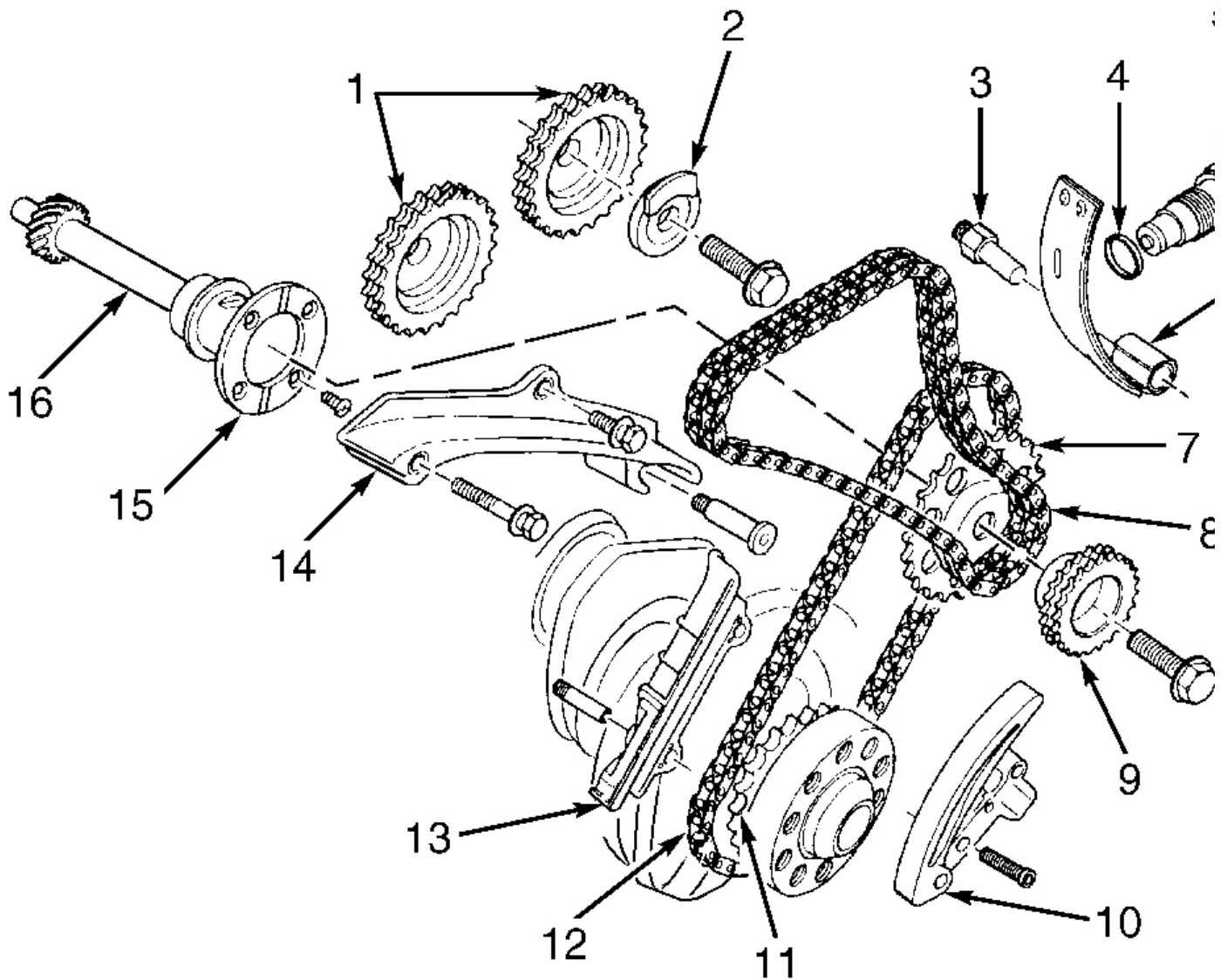

- | | |
|-------------------------------------|--------------------------------------|
| 1. Camshaft Sprocket | 9. Double Chain Sprocket |
| 2. Sensor Wheel | 10. Single Chain
Tensioning Plate |
| 3. Pivot Pin | 11. Crankshaft Sprocket |
| 4. Seal | 12. Single Chain |
| 5. Chain Tensioner | 13. Single Chain Guide Rail |
| 6. Double Chain
Tensioning Plate | 14. Double Chain Guide Ra |
| 7. Single Chain Sprocket | 15. Thrust Washer |
| 8. Double Chain | 16. Intermediate Shaft |

G98F10731

Fig. 9: Exploded View Of Timing Chain & Related Components
 Courtesy of VOLKSWAGEN UNITED STATES, INC.

Installation

1994 Volkswagen Corrado SLC

2.8L VR6

Leave Camshaft Guide (3268) installed. Ensure crankshaft is aligned at TDC. See **Fig. 10** . Ensure intermediate shaft is correctly aligned. See **Fig. 11** . Install timing chain on sprockets. Reverse removal procedure to complete installation

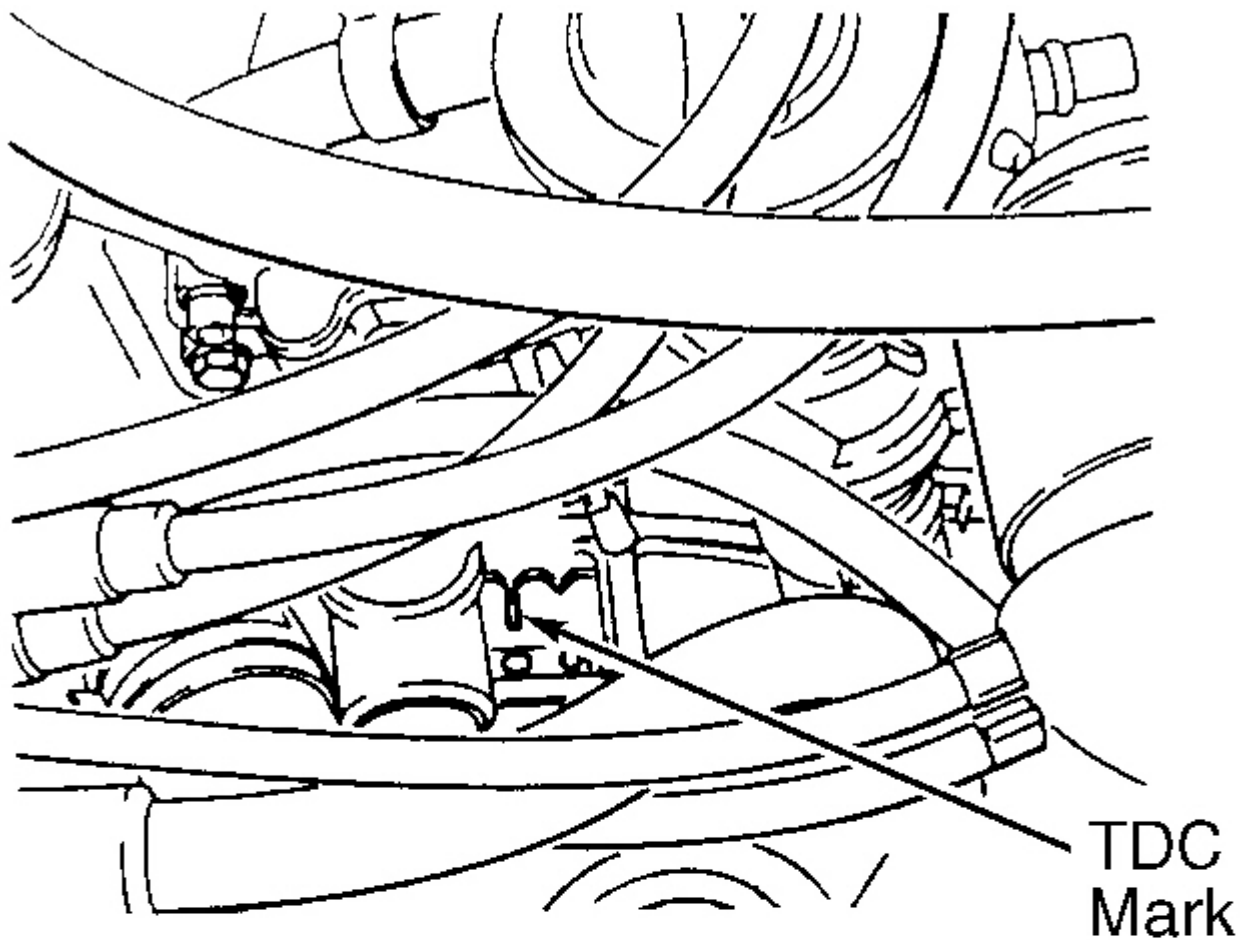

WITH TRANSAXLE INSTALLED

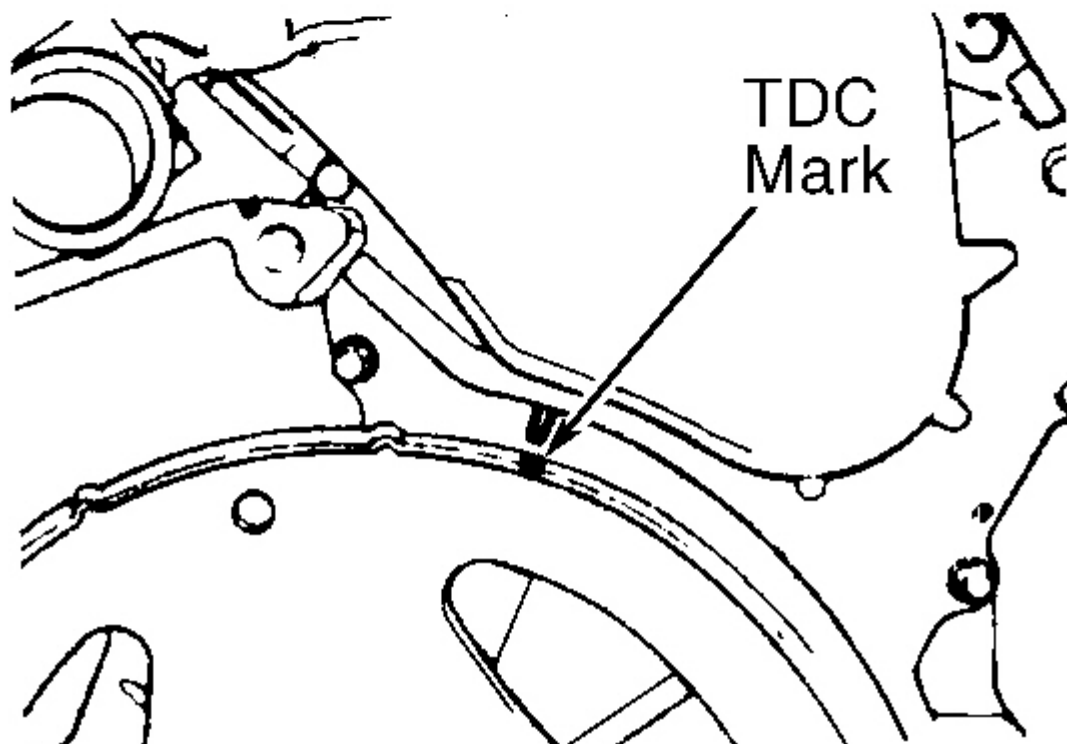
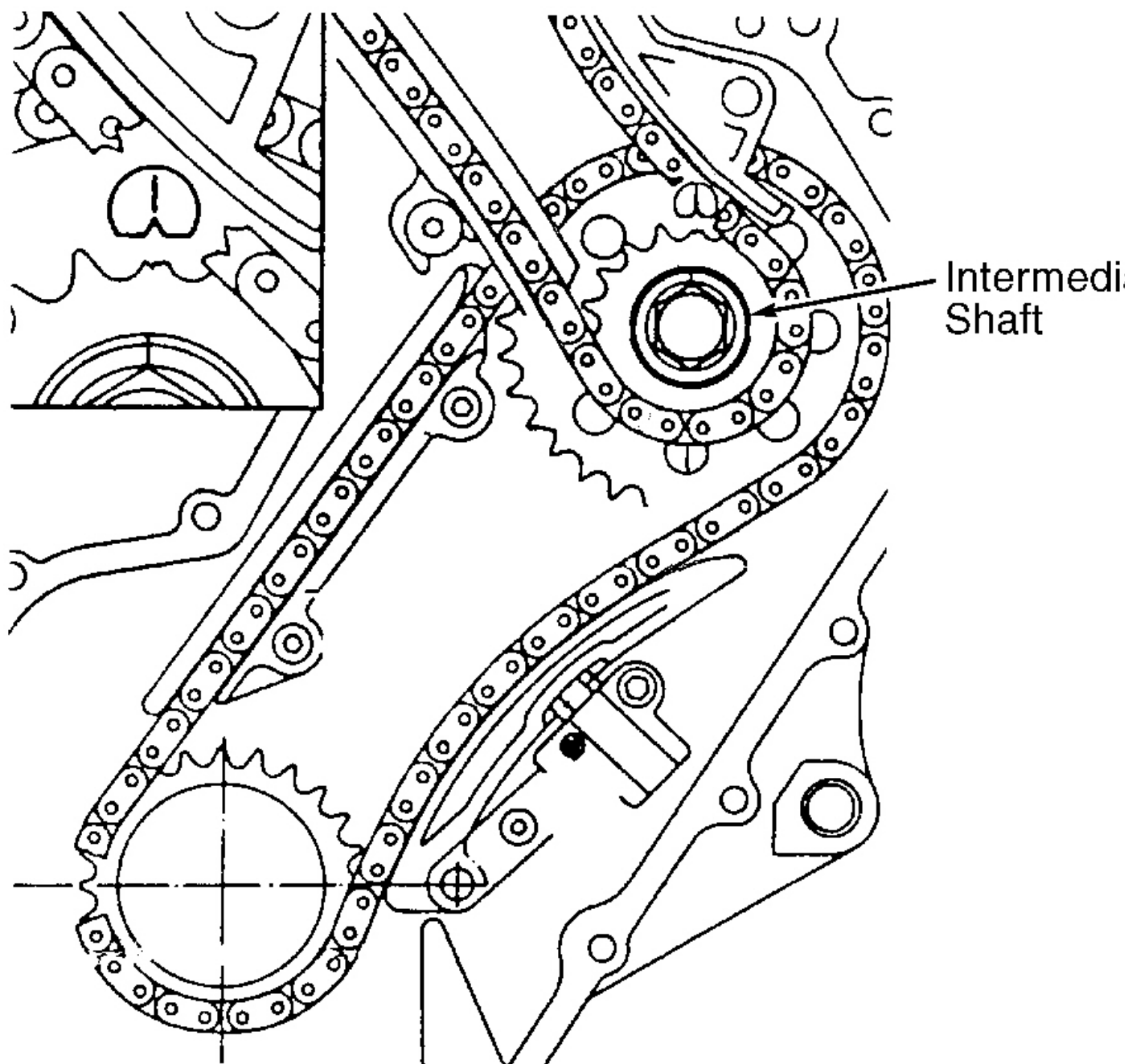

Fig. 10: Aligning Crankshaft At TDC

Courtesy of VOLKSWAGEN UNITED STATES, INC.



G93C83115

Fig. 11: Aligning Intermediate Shaft At TDC

Courtesy of VOLKSWAGEN UNITED STATES, INC.

CAMSHAFT**Removal**

Remove valve cover. Place crankshaft at TDC. Remove ignition coil. Remove double chain tensioner. Remove camshaft sprocket cover with camshaft position sensor attached. Remove camshaft sprockets. Mark timing chains for direction of rotation. If removing camshaft for cylinders 1, 3 and 5, remove bearing caps

No. 1 and No. 7 first then remove bearing caps No. 3 and No. 5. If removing camshaft for cylinders 2, 4 and 6, remove bearing cap No. 4 first then remove bearing caps No. 2 and No. 6. Remove camshafts.

Inspection

Check camshaft bearing oil clearance. See **CAMSHAFT** table under ENGINE SPECIFICATIONS. If oil clearance exceeds specification, install new camshaft and recheck clearance. If clearance still exceeds specification, replace cylinder head.

Installation

1. Lubricate all contact surfaces. When installing bearing caps, ensure identification mark on bearing cap is readable from exhaust manifold side and arrow points toward vibration damper. See **Fig. 12**.
2. If installing camshaft for cylinders No. 1, 3 and 5, tighten bearing caps No. 3 and 5 alternately in a diagonal sequence to 15 ft. lbs. (20 N.m). Repeat procedure for bearing caps No. 1 and 7.
3. If installing camshaft for cylinders No. 2, 4 and 6, tighten bearing caps No. 2 and 6 alternately in a diagonal sequence to 15 ft. lbs. (20 N.m). Repeat procedure for bearing cap No. 4.
4. To complete installation, reverse removal procedure. Ensure timing marks are properly aligned. If lifters are charged with oil, allow 30 minutes for lifters to bleed down before starting engine. Otherwise valves may come in contact with pistons.

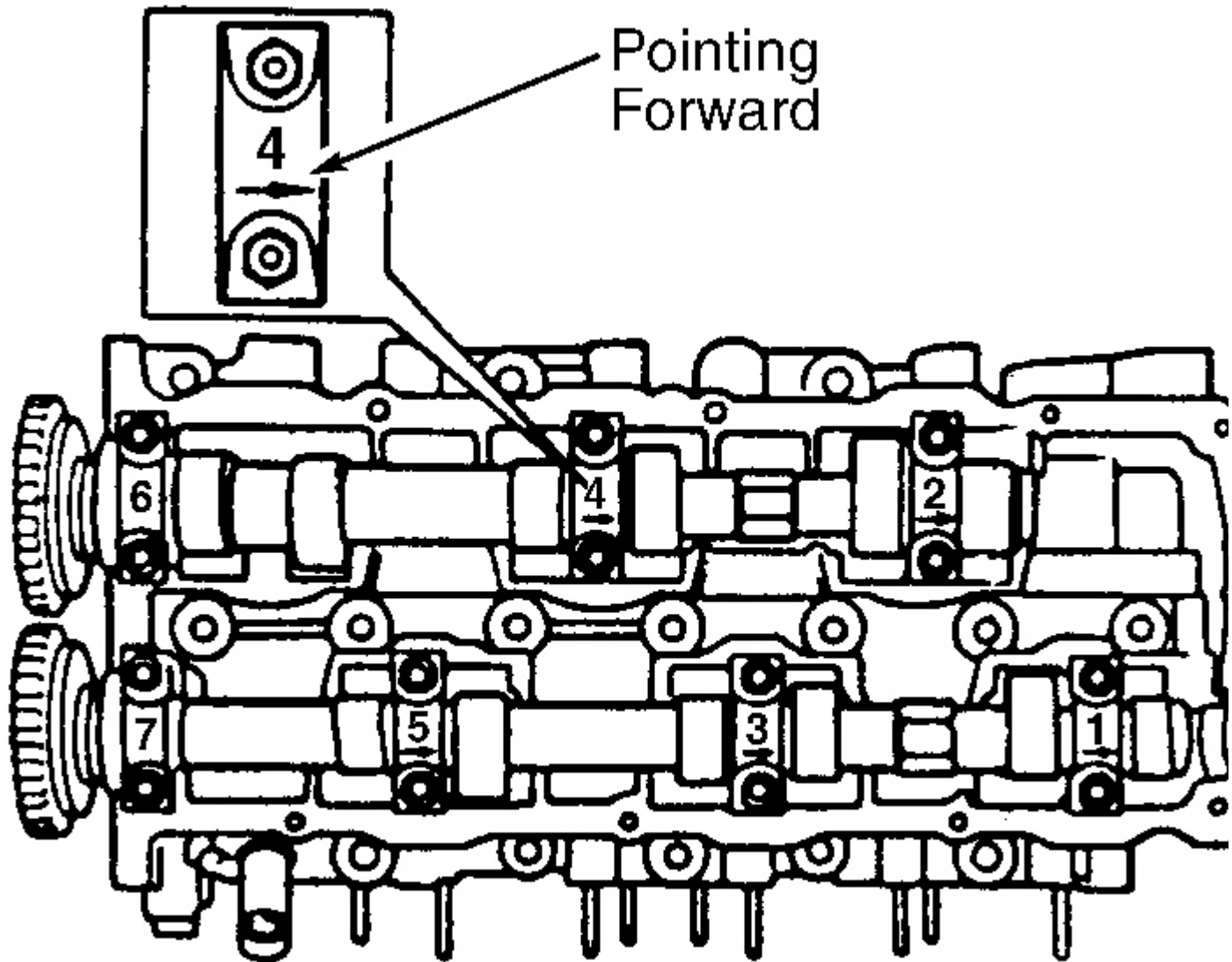

G93D83116

Fig. 12: Installing Camshafts Into Cylinder Head
 Courtesy of VOLKSWAGEN UNITED STATES, INC.

VALVE LIFTERS

Removal & Installation

Remove camshaft. See **CAMSHAFT**. Remove valve lifters from cylinder head. Note position of each lifter. If lifters are reused, they **MUST** be installed in original position. If replacement lifters are charged with oil, allow 30 minutes for lifters to bleed down before starting engine. Otherwise, valves may come in contact with pistons. To complete installation, reverse removal procedure.

WATER PUMP

NOTE: Coolant/water mixture should be used at all times.

Removal

1. Obtain radio security code. Turn ignition off and wait for 20 seconds. Disconnect negative battery

1994 Volkswagen Corrado SLC

2.8L VR6

cable. Drain cooling system. Disconnect front exhaust pipe from catalytic converter.

2. Install 8-mm bolt in belt tensioner hole and remove drive belt. See **Fig. 2** . Remove ignition cable guide. Disconnect front and rear motor mounts. Attach Engine Sling (2024A) to engine. See **Fig. 3** .
3. Lift engine enough to access water pump. Secure pulley using Spanner Wrench (VAG 1590). Remove water pump bolts. Push engine toward left side and remove water pump.

Installation

When installing motor mounts, ensure that recess on engine bracket fits into mounting tab of bonded rubber bushing. Hand tighten motor mount bolts and light rock engine to ensure motor mounts are fully seated. To complete installation, reverse removal procedure.

OIL PAN

Information is not available from manufacturer.

OVERHAUL

CYLINDER HEAD

Cylinder Head

Clean all gasket mating surfaces. Check cylinder head for warpage. Ensure warpage does not exceed .004" (0.1 mm).

Valve Stem Oil Seals

With valve springs removed, remove oil seals using Valve Seal Remover (3047A). To install new oil seal, slide plastic sleeve over valve stem. Lubricate new oil seal. Using Valve Seal Installer (3129), push oil seal on valve guide.

Valve Guides

1. Check valve-to-guide clearance specification. See **CYLINDER HEAD** table under ENGINE SPECIFICATIONS. If valve guides have previously been replaced, replace cylinder head.
2. To replace valve guide, press guide out from camshaft side. Lubricate guide and press in cold cylinder head (from camshaft side) until shoulder makes contact. DO NOT exceed one ton pressure. Ream guides to proper valve-to-guide clearance. See **CYLINDER HEAD** table under ENGINE SPECIFICATIONS.

Valve Seats

1. Check valve seats before any other cylinder head service. Insert the valve and hold firmly against the valve seat. Measure valve stem tip-to-cylinder head distance. See **Fig. 13** . This measurement determines installed valve height. Subtract measured distance from minimum specification. See **MINIMUM VALVE INSTALLED HEIGHT** table.
2. The difference is maximum refacing allowable for valve and seat. If valve installed height is too low or too high, lifters will not work correctly. Replace cylinder head assembly.

MINIMUM VALVE INSTALLED HEIGHT

Application	In. (mm)

Intake Valve	1.33 (33.9)
Exhaust Valve	1.34 (34.1)

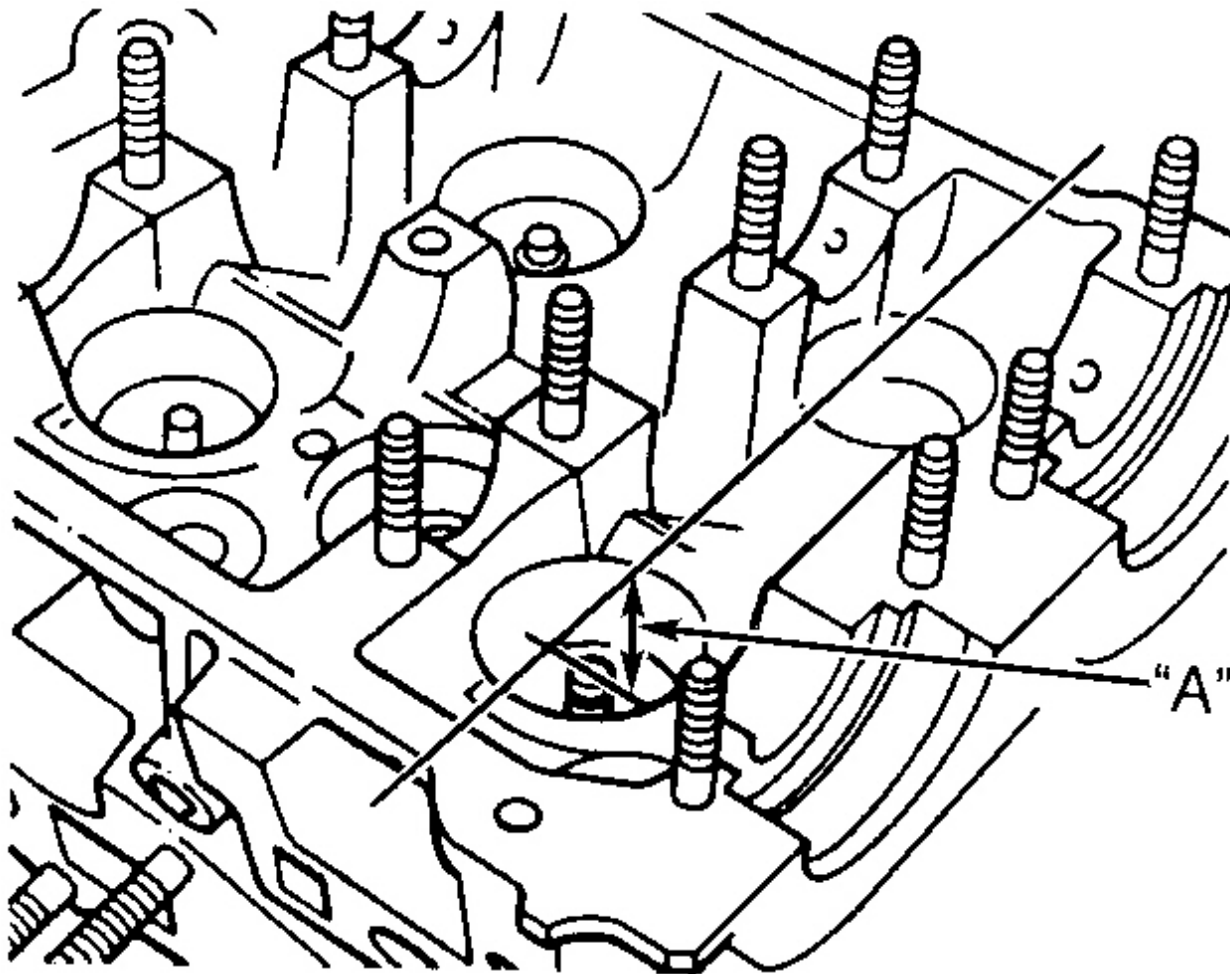

"A" = Valve Stem-To-Cylinder Head Measureme

G93E83117

Fig. 13: Measuring Valve Installed Height

Courtesy of VOLKSWAGEN UNITED STATES, INC.

Valves

Measure valve length, stem diameter and valve margin. If not within specification, replace valves. Lap valves by hand or replace as necessary. See **VALVES** table under ENGINE SPECIFICATIONS.

HYDRAULIC LIFTER TEST

To determine weak or noisy lifter, position camshaft lobe high point upward. Using a piece of wood, push lifter down. See **Fig. 14** . If lifter moves down more than .004" (.10 mm), replace lifter. If lifter moves less than .004" (.10 mm), lifter is okay. Repeat procedure for remaining lifters.

CAUTION: If replacement lifter is charged with oil, allow 30 minutes for lifter to bleed

down before starting engine. Otherwise, valves may come in contact with pistons.

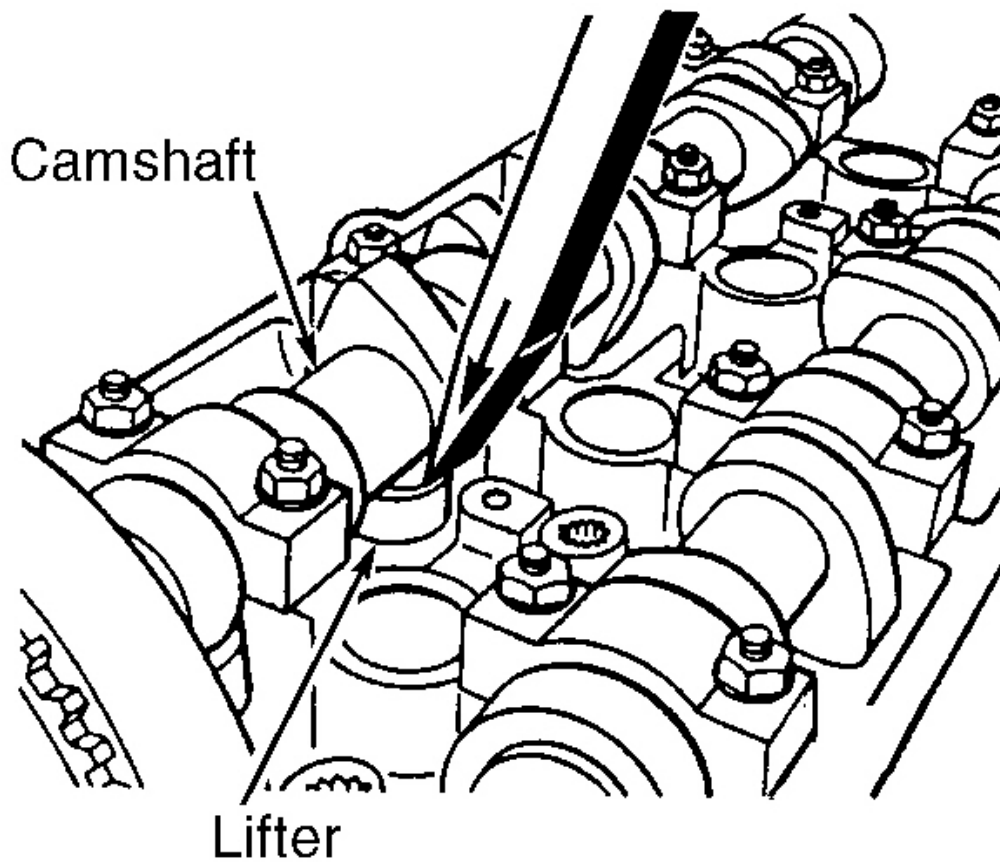

G93I83103

Fig. 14: Depressing Lifter

Courtesy of VOLKSWAGEN UNITED STATES, INC.

CYLINDER BLOCK ASSEMBLY

Piston & Rod Assembly

1. Make sure piston, rod and rod caps are marked with matching cylinder number prior to removal. Ensure arrow on top of piston points toward pulleys. Ensure marks on rod and cap are positioned correctly. See **Fig. 15** . Rod cap bolts and nuts must be replaced after removing or loosening.

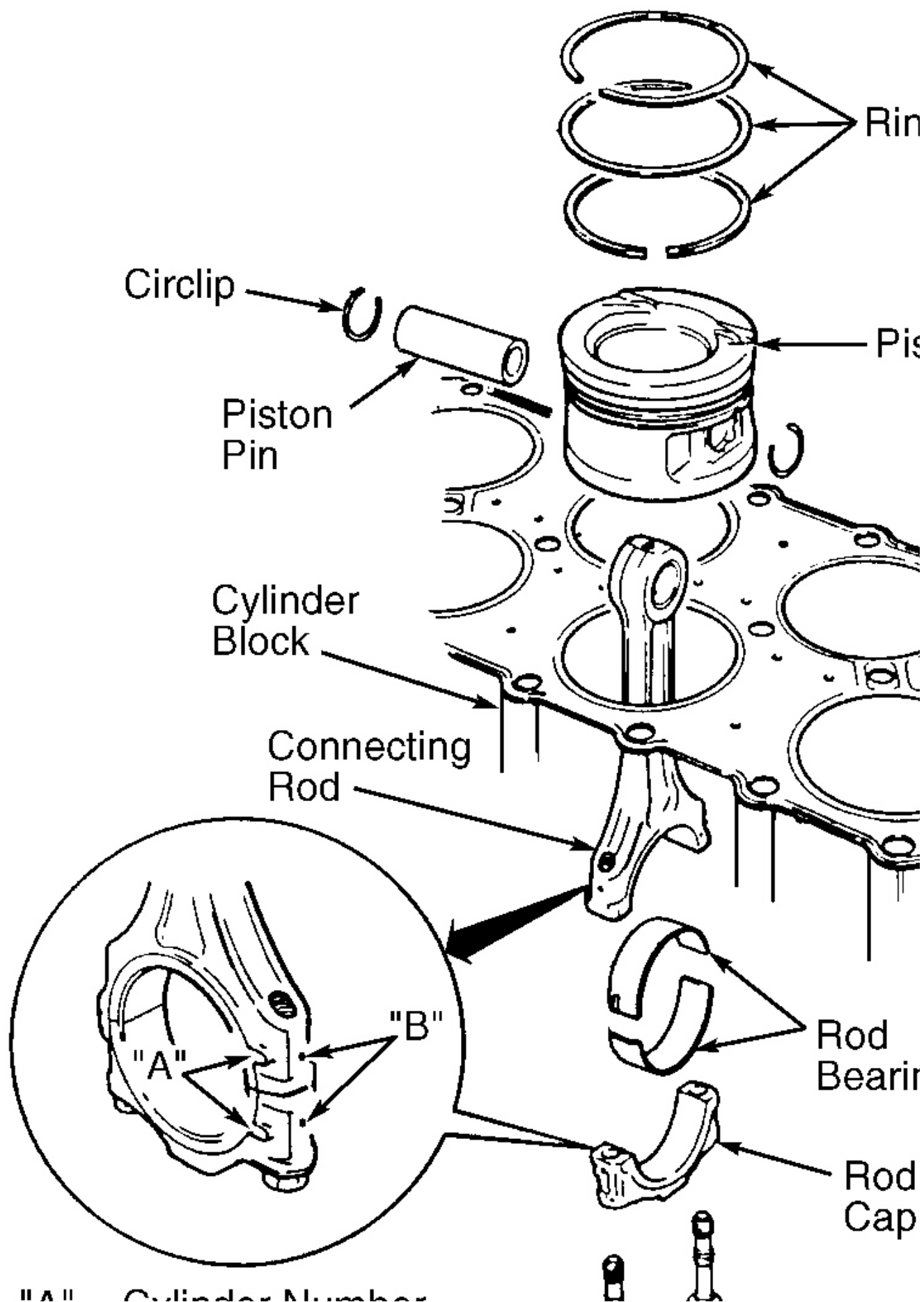

"A" Cylinder Number

Fig. 15: Assembling Piston & Rod

Courtesy of VOLKSWAGEN UNITED STATES, INC.

2. Mark piston in relation to pin. Remove circlips from ends of pin bore. Use Piston Pin Replacer/Installer (VW 222A) to remove and install piston pin. If pin is too tight, heat piston to 140°F (60°C). Ensure rod is properly positioned with piston.

Fitting Pistons

Measure clearances with cylinder block supported on work bench. Check clearance of piston-to-cylinder bore. Piston diameter is stamped on top of piston in millimeters.

PISTON-TO-CYLINDER BORE DIMENSIONS

Size	Piston Diameter	Cylinder Bore
Standard	3.188" (80.98 mm)	3.189" (81.01 mm)
1st Over	3.208" (81.49 mm)	3.209" (81.51 mm)
2nd Over	3.228" (81.98 mm)	3.229" (82.01 mm)

Piston Rings

1. Measure ring end gap. Measure ring side clearance with piston. Replace if necessary. See **PISTONS, PINS & RINGS** table under ENGINE SPECIFICATIONS.
2. Install rings on piston with TOP mark facing upward. Recessed edge on outside of center ring must face piston pin (down). Position ring gaps on piston at 120 degree intervals.

Connecting Rod Bearings

Mark rod caps for reinstallation. Use Plastigage to measure bearing clearances. Measure connecting rod side play. Replace or machine as necessary. See **CRANKSHAFT, MAIN & CONNECTING ROD BEARINGS** table under ENGINE SPECIFICATIONS. Tighten evenly to specification in several steps. See **TORQUE SPECIFICATIONS**.

Crankshaft & Main Bearings

Main bearing caps are marked with matching journal for installation in original position. See **Fig. 16**. Measure crankshaft end play. See THRUST BEARING.

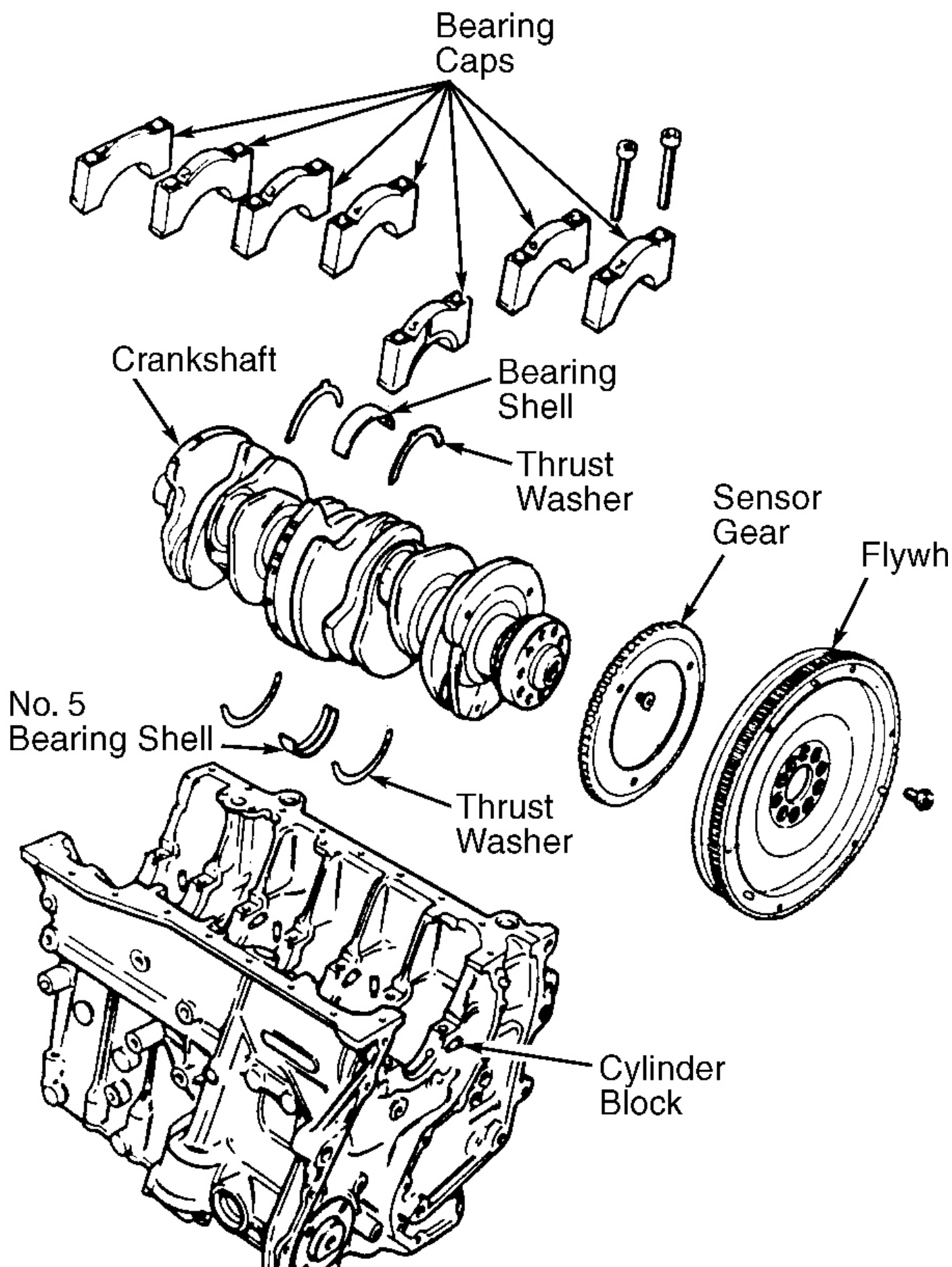

Fig. 16: Exploded View Of Crankshaft Assembly
 Courtesy of VOLKSWAGEN UNITED STATES, INC.

Thrust Bearing

Insert feeler gauge between No. 5 main bearing and crankshaft thrust face to measure end play. See **Fig. 16**. Replace thrust bearing as necessary. See **CRANKSHAFT, MAIN & CONNECTING ROD BEARINGS** table under ENGINE SPECIFICATIONS.

Cylinder Block

Check cylinder bore for wear, out-of-round and taper. Check cylinder block for warpage. See **CYLINDER BLOCK** table under ENGINE SPECIFICATIONS.

ENGINE OILING

ENGINE LUBRICATION SYSTEM

Crankcase Capacity

See **CRANKCASE CAPACITY** table.

CRANKCASE CAPACITY

Application	Specification
With Filter Replacement	5.8 Qts. (5.5L)
Without Filter Replacement	5.3 Qts. (5.0L)

Oil Pressure

Check oil pressure with engine at warm operating temperature. Minimum oil pressure at 2000 RPM is 29 psi (2.0 kg/cm²). If oil pressure is incorrect, check oil pump and oil pressure relief valve.

OIL PUMP

Removal & Installation

Remove oil pan. Remove oil pump attaching bolts and remove oil pump assembly. To install, reverse removal procedure.

Inspection

Check oil pump housing, gears and pressure relief valve for damage or excessive wear. See **Fig. 17**. Repair or replace as an assembly.

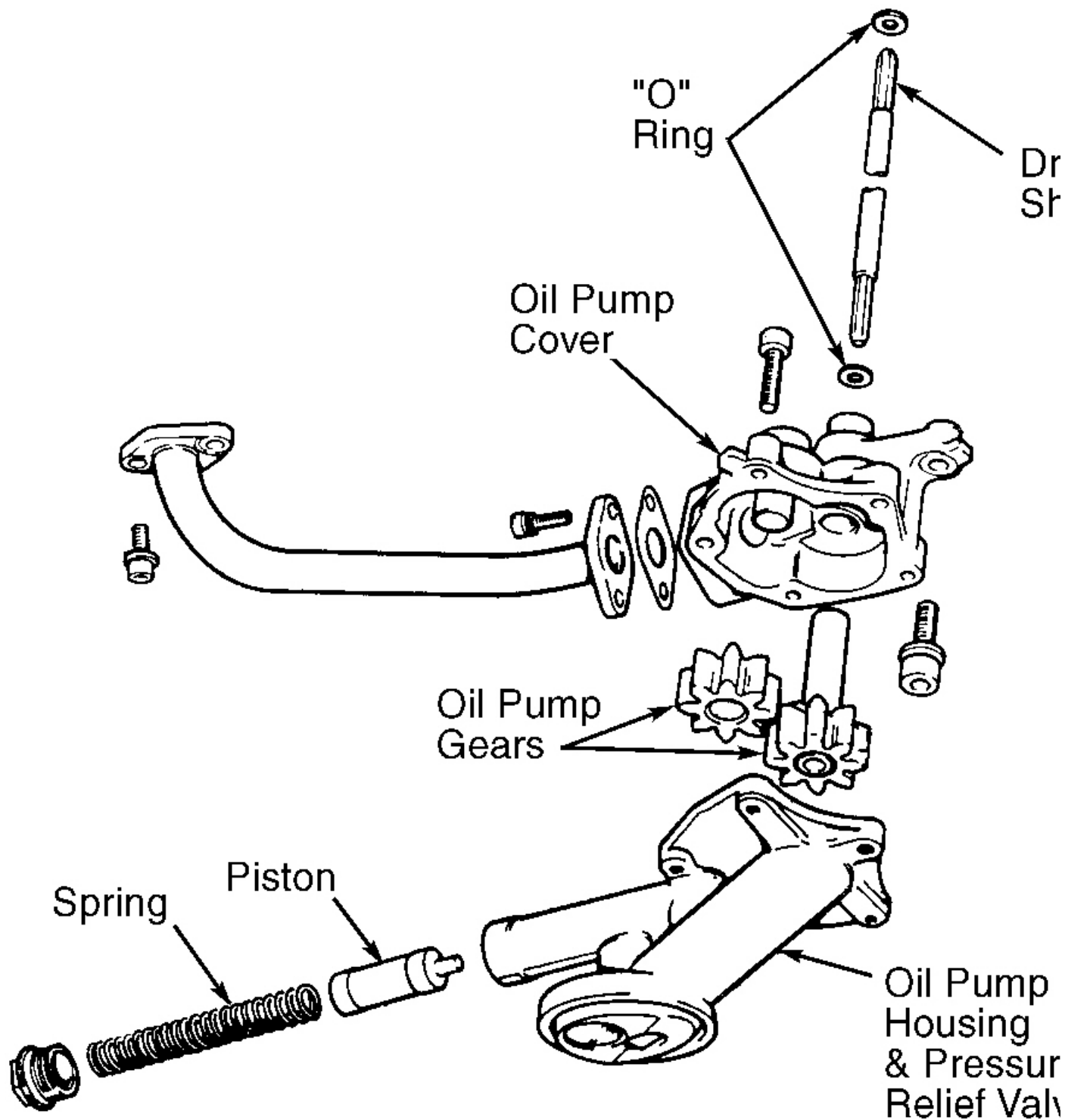

G93J83120

Fig. 17: Oil Pump Assembly

Courtesy of VOLKSWAGEN UNITED STATES, INC.

TORQUE SPECIFICATIONS

TORQUE SPECIFICATIONS

Application	Ft. Lbs. (N.m)

1994 Volkswagen Corrado SLC

2.8L VR6

A/C Bracket-To-Engine Bolt	18 (25)
Axle Shaft-To-Transaxle Drive Flange Bolt	33 (45)
Camshaft Bearing Cap Bolt	15 (20)
Camshaft Sprocket Bolt	74 (100)
Connecting Rod Bolt	
Step 1	22 (30)
Step 2	Additional 1/4 Turn (90 Degrees)
Crankshaft Main Bearing Cap Bolt	
Step 1	22 (30)
Step 2	Additional 1/2 Turn (180 Degrees)
Cylinder Head Bolt ⁽¹⁾	
Step 1	30 (40)
Step 2	44 (60)
Step 3	Additional 1/4 Turn (90 Degrees)
Step 4	Additional 1/4 Turn (90 Degrees)
Engine Bracket (Front)	44 (60)
Engine Bracket (To Body)	44 (60)
Engine-To-Transaxle	
M12 Bolt	59 (80)
M10 Bolt	44 (60)
M7 Bolt	(2)
M6 Bolt	(2)
Exhaust Manifold-To-Cylinder Head Bolt & Nut	18 (25)
Exhaust Pipe-To-Catalytic Converter Bolt	18 (25)
Exhaust Pipe-To-Manifold Nut	30 (40)
Flywheel-To-Crankshaft Bolt	
Step 1	44 (60)
Step 2	Additional 1/4 Turn (90 Degrees)
Guide Rail Bolt	15 (20)
Intake Manifold	18 (25)
Intermediate Shaft Sprocket Bolt	74 (100)
Oil Pan Bolt	11 (15)
Oil Pan Drain Plug	22 (30)
Oil Pressure Switch	18 (25)
Oil Pump Cover Long Bolt	(2)
Oil Pump Cover Short Bolt	18 (25)
Power Steering Pump Bracket Bolt	18 (25)
Pressure Plate Bolt	15 (20)
Starter Mount Bolt	44 (60)
Timing Chain (Double Row) Tensioner Nut	22 (30)
Torque Converter-To-Carrier Plate Bolt	22 (30)
Vibration Damper Bolt	

1994 Volkswagen Corrado SLC

2.8L VR6

Step 1	89 (120)
Step 2	Additional 1/4 Turn (90 Degrees)
Water Pump Pulley Bolt	18 (25)
Water Pump Housing-To-Engine Bolt	15 (20)
INCH Lbs. (N.m)	
Fuel Rail Bolt (Lower)	89 (10)
Intermediate Shaft Retainer Plate Bolt	89 (10)
Sensor Wheel Bolt	
Step 1	89 (10)
Step 2	Additional 1/4 Turn (90 Degrees)
Timing Chain (Single Row) Tensioner Bolt	89 (10)
Valve Cover Retaining Nut	89 (10)
<p>(1) Never reuse cylinder head bolt(s) when servicing.</p> <p>(2) Tighten bolt to 89 INCH lbs. (10 N.m).</p>	

ENGINE SPECIFICATIONS

GENERAL SPECIFICATIONS

GENERAL SPECIFICATIONS

Application	Specification
Displacement	170 Cu. In.
Bore	3.19" (81.0 mm)
Stroke	3.56" (90.3 mm)
Compression Ratio	10.0:1
Fuel System	Motronic SFI
Horsepower @ RPM	172 @ 5800
Torque Ft. Lbs @ RPM	173 @ 4200

CRANKSHAFT, MAIN & CONNECTING ROD BEARINGS

CRANKSHAFT, MAIN & CONNECTING ROD BEARINGS

Application	In. (mm)
Crankshaft	
End Play	
Standard	.003-.009 (.07-.23)
Service Limit	.012 (.30)
Runout	.001 (.03)
Main Bearings	
Journal Diameter	2.361-2.362 (59.958-59.978)
Journal Out-Of-Round	.001 (.03)
Journal Taper	.001 (.03)
Oil Clearance	

1994 Volkswagen Corrado SLC

2.8L VR6

Standard	.0008-.0020 (.02-.06)
Service Limit	.0039 (.100)
Connecting Rod Bearings	
Journal Diameter	2.124-2.125 (53.958-53.978)
Journal Out-Of-Round	.001 (.03)
Journal Taper	.001 (.03)
Oil Clearance	
Standard	.0004-.0020 (.01-.06)
Service Limit	.0039 (.100)

PISTONS, PINS & RINGS

PISTONS, PINS & RINGS

Application	In. (mm)
Pistons	
Clearance	.0016 (.040)
Diameter	3.188 (80.99)
Pins	
Diameter	(1)
Piston Fit	Interference Fit
Rod Fit	Interference Fit
Rings	
No. 1	
End Gap	
Standard	.008-.016 (.20-.40)
Service Limit	.0039 (.100)
Side Clearance	
Standard	.001-.003 (.02-.07)
Service Limit	.006 (.15)
No. 2	
End Gap	
Standard	.008-.016 (.20-.40)
Service Limit	.0039 (.100)
Side Clearance	
Standard	.001-.003 (.02-.07)
Service Limit	.006 (.15)
No. 3 (Oil)	
End Gap	
Standard	.010-.020 (.25-.50)
Service Limit	.0039 (.100)
Side Clearance	.001-.002 (.02-.05)
(1) Information is not available from manufacturer.	

1994 Volkswagen Corrado SLC

2.8L VR6

CYLINDER BLOCK**CYLINDER BLOCK**

Application	In. (mm)
Cylinder Bore	
Standard Diameter	3.189 (81.01)
Maximum Taper	.0032 (.08)
Maximum Out-Of-Round	.001 (.03)

OIL PUMP**OIL PUMP**

Application	Specification
Pump Gear Clearance	
Radial (Maximum)	.008" (.20 mm)
Axial (Maximum)	.0039" (.100 mm)

VALVES**VALVES**

Application	Specification
Intake Valves	
Face Angle	45°
Head Diameter	1.535" (39.00 mm)
Length	4.1713" (105.95 mm)
Minimum Margin ⁽¹⁾	(2)
Stem Diameter	.2744" (6.97 mm)
Exhaust Valves	
Face Angle	45°
Head Diameter	1.346" (34.20 mm)
Length	4.2106" (106.95 mm)
Minimum Margin ⁽¹⁾	(2)
Stem Diameter	.2736" (6.95 mm)
(1) DO NOT machine valves; hand lap only.	
(2) Information is not available from manufacturer.	

CYLINDER HEAD**CYLINDER HEAD**

Application	Specification
Cylinder Head Height (Minimum)	5.492" (139.5 mm)
Maximum Warpage	.0039" (.100 mm)
Valve Seats	
Intake Valve	

1994 Volkswagen Corrado SLC

2.8L VR6

Seat Angle	45°
Seat Width	.055-.079" (1.4-2.0 mm)
Exhaust Valve	
Seat Angle	45°
Seat Width	.079-.098" (2.0-2.5 mm)
Valve Guides	
Intake Valve	
Valve Guide Installed Height	(1)
Oil Clearance	(2) .040" (1.0 mm)
Exhaust Valve	
Valve Guide Installed Height	(1)
Valve Stem-to-Guide Oil Clearance	(2) .051" (1.30 mm)
<p>(1) Valve guide shoulder flush with cylinder head.</p> <p>(2) New valve installed in cylinder head. Dial indicator used to measure valve rock in guide.</p>	

CAMSHAFT

CAMSHAFT

Application	In. (mm)
End Play	.006 (.15)
Oil Clearance	.0039 (.100) Maximum
Runout	.0004 (.01) Maximum