

1.8L 4-CYL 8-VALVE & 2.0L 4-CYL 16-VALVE Article Text

This file passed thru Volkswagen Technical Site - <http://volkswagen.msk.ru>

ARTICLE BEGINNING

1992 VOLKSWAGEN ENGINES
1.8L 8-Valve & 2.0L 16-Valve 4-Cylinder

Cabriolet, Corrado, Fox, Golf, GTI, Jetta, Passat

*** PLEASE READ THIS FIRST ***

NOTE: For engine repair procedures not covered in this article, see **ENGINE OVERHAUL PROCEDURES - GENERAL INFORMATION** article in the **GENERAL INFORMATION** section.

ENGINE IDENTIFICATION

Engine identification number is stamped on a machined pad, left side of engine block, near distributor assembly (1.8L) or over crankcase ventilation area (2.0L). See Fig. 1. The first 2 characters (3 characters on Fox) designate engine code.

ENGINE IDENTIFICATION CODES TABLE

Application	Engine Code
1.8L 8-Valve 4-Cylinder	
Cabriolet	2H
Corrado	PG
Fox	ABG
Golf	RV
GTI	PF Or RV
Jetta	
Carat Federal	PF
Except Carat Federal	RV
2.0L 16-Valve 4-Cylinder	
GTI, Jetta GLi & Passat	9A

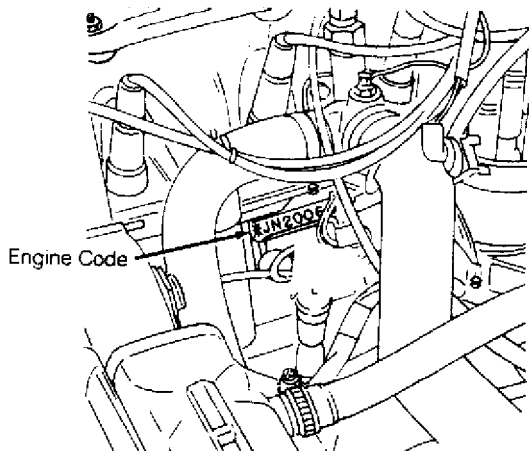

Fig. 1: Locating Engine Identification Number
Courtesy of Volkswagen United States, Inc.

ADJUSTMENTS

HYDRAULIC LIFTER (CAM FOLLOWER) TEST

To determine weak or noisy lifter, position camshaft lobe high point upward. Using a piece of wood, push cam follower down. See Fig. 3 or 4. If cam follower moves down more than .004" (.10 mm), replace cam follower. If cam follower moves less than .004" (.10 mm), cam follower is okay. Repeat procedure for remaining cam followers.

REMOVAL & INSTALLATION

NOTE: Match mark engine mounts to ensure original alignment position after installation. On vehicles with Power Steering (P/S), remove P/S unit with hoses attached and secure out of way.

FUEL PRESSURE RELEASE

On models with Digifant fuel injection, remove fuel pump relay (located in fuse/relay panel. Crank engine for 5 seconds. Reinstall fuel pump relay. On models with CIS-E fuel injection, apply 12 volts to cold start injector valve for 3-5 seconds.

ENGINE

Removal (Except Fox)

1) Disconnect and remove battery. Open fuel tank fill cap and radiator cap. Remove intake air duct. On 16-valve engines, remove intake manifold assembly. On vehicles with A/C, remove trim panel and lower apron. Remove A/C condenser and radiator. Remove all duct work. Label and disconnect A/C and cooling fan electrical connectors. Remove accessory drive belts.

2) On Golf, GTI, Jetta and Passat, leave A/C hoses attached and remove A/C compressor. Pivot A/C condenser and compressor to side of vehicle and secure.

3) On Corrado, remove G-Charger compressor. On Cabriolet and Corrado, remove alternator and timing belt cover. Remove 3 A/C bracket Allen head bolts behind timing belt cover. Remove A/C bracket support brace. Remove A/C compressor bracket bolts. Leave hoses attached and secure A/C compressor with bracket out of way.

4) On all models, open heater controls. Remove cooling hose from thermostat housing flange and drain coolant. Remove thermostat housing flange. Label and remove all cooling system hoses.

5) On Golf, GTI, Jetta and Passat, remove grille from radiator support. Disconnect electrical connectors at radiator support. Remove radiator-to-support bolts. Remove radiator support using care not damage headlights. Remove radiator, fan and shroud assembly.

6) On all models, remove axle shafts from transaxle. See FRONT WHEEL DRIVE AXLES SHAFTS article in the DRIVE AXLES Section. Label and disconnect shift linkage and speedometer cable. Label and disconnect electrical connectors and vacuum hoses. Disconnect throttle, cruise and kickdown cables. On Golf, Jetta GLi and Passat, leave fuel lines connected and remove cold start injector and warm-up regulator.

7) On all models, remove fuel injectors. Remove rear engine mount. Remove complete transaxle mount. Disconnect exhaust pipe from exhaust manifold. On Cabriolet and Corrado, remove right front tire assembly. Remove right and left engine mount through bolts.

8) On all models, install engine sling on engine lift hooks. Carefully raise engine and transaxle out of vehicle. Separate transaxle from engine.

Installation

1) To install, reverse removal procedure. Engine alignment adjustment is necessary whenever engine is removed or mounts are loosened. To adjust, loosen through bolt on engine mount "A". Loosen transmission transaxle mount "B" bolts. Loosen front engine mount and bracket. See Fig. 2.

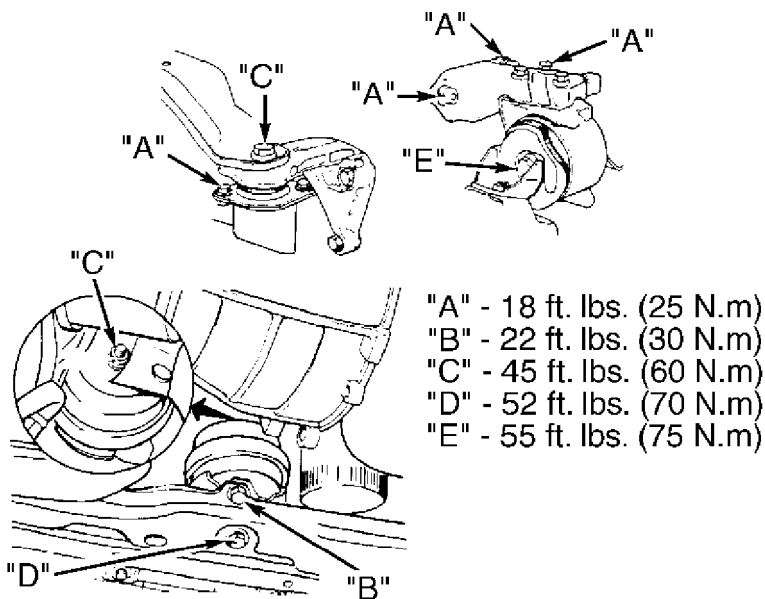

G98950

Fig. 2: Aligning Engine/Transaxle Assembly
 Courtesy of Volkswagen United States, Inc.

2) Lightly rock engine and transaxle to allow position to shift as necessary. Evenly tighten mount bolts in reverse order of loosening. Fill fluids to proper level. Adjust clutch pedal (if equipped). Tighten all bolts and nuts to specification. See TORQUE SPECIFICATIONS table at end of article.

Removal (Fox)

1) Disconnect negative battery cable. Open heater valve. Drain radiator. Remove fan, shroud and radiator. Remove M/T clutch cable (if equipped).

2) Label and disconnect electrical wiring and vacuum hoses. Disconnect throttle, cruise and kickdown linkage. Remove air duct from intake manifold. Remove charcoal canister and set aside.

3) Remove 3 upper engine-to-transaxle bolts. Remove left and right engine mount nuts. Disconnect and remove starter. Remove 2 lower engine-to-transaxle bolts. Remove transaxle inspection cover plate. Disconnect exhaust pipe bracket and disconnect exhaust pipe from exhaust manifold.

4) Support transaxle. Attach engine sling to engine lifting hooks. Raise engine/transaxle until engine clears engine mounts. Ensure transaxle is supported. Remove remaining engine-to-transaxle bolts. Lift and separate engine from vehicle and transaxle.

Installation

Lubricate transaxle main shaft splines and contact area between clutch release bearing and clutch pressure plate with molybdenum disulfide grease. DO NOT lubricate guide sleeve for clutch release bearing. To complete installation, reverse removal procedure. Use NEW self-locking nuts. Ensure engine mounts are installed to original location. Tighten engine mounts and subframe bolts to specification with engine running at idle. See TORQUE SPECIFICATIONS table at end of article.

INTAKE MANIFOLD

Removal and installation procedure is not available from manufacturer. See TORQUE SPECIFICATIONS table at end of article.

EXHAUST MANIFOLD

Removal and installation procedure is not available from manufacturer. See TORQUE SPECIFICATIONS table at end of article.

CYLINDER HEAD

Removal

1) Removal and installation procedure is not available from manufacturer. Cylinder head may be removed with engine in vehicle. Match mark all components for installation reference. Remove timing belt. See TIMING BELT under REMOVAL & INSTALLATION. See Fig. 3 or 4.

2) Remove cylinder head bolts in reverse sequence of installation. See Fig. 5. Replace cylinder head bolts after loosening or removing.

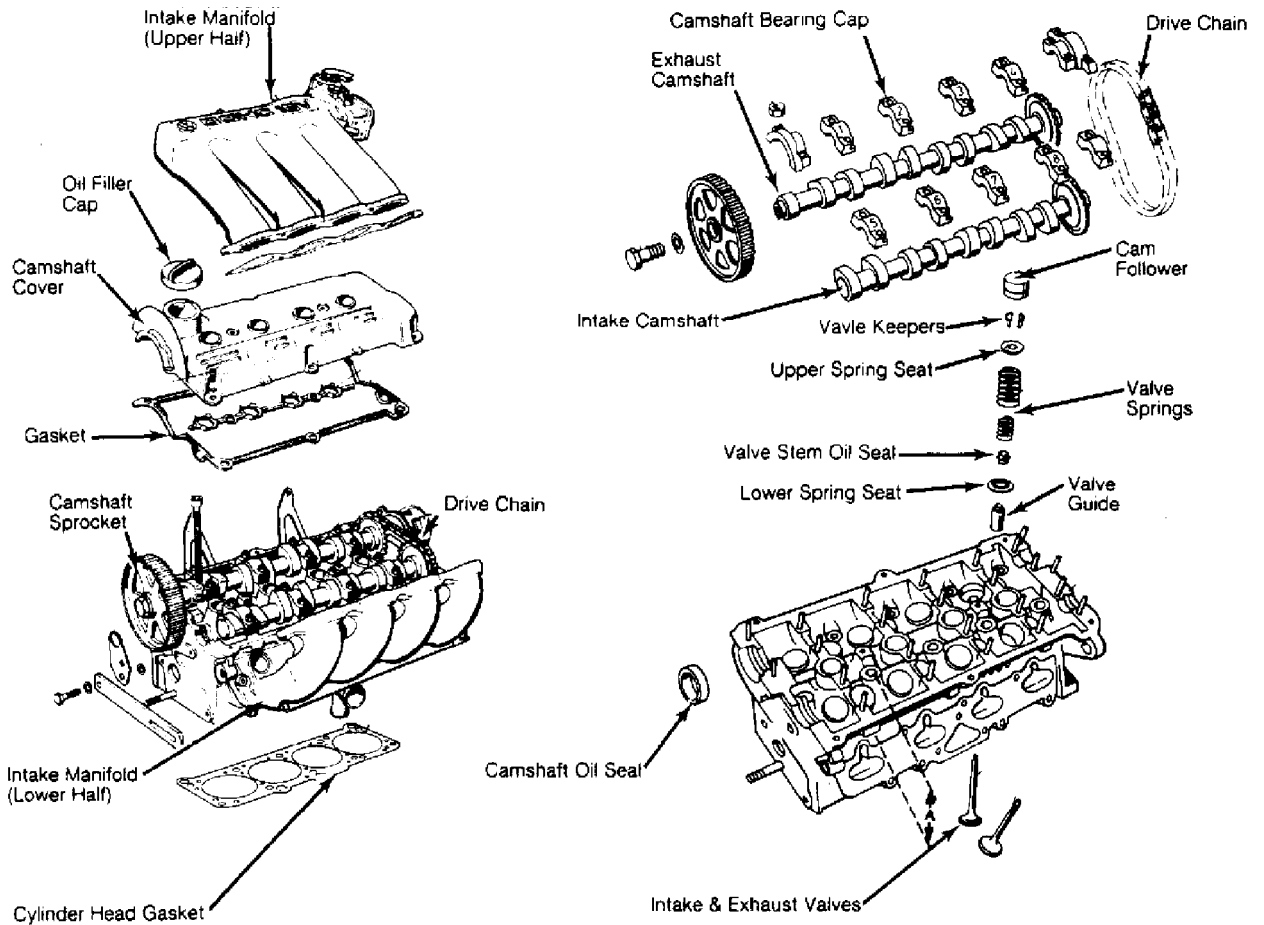

Fig. 3: Identifying 2.0L Cylinder Head (16-Valve)
Courtesy of Volkswagen United States, Inc.

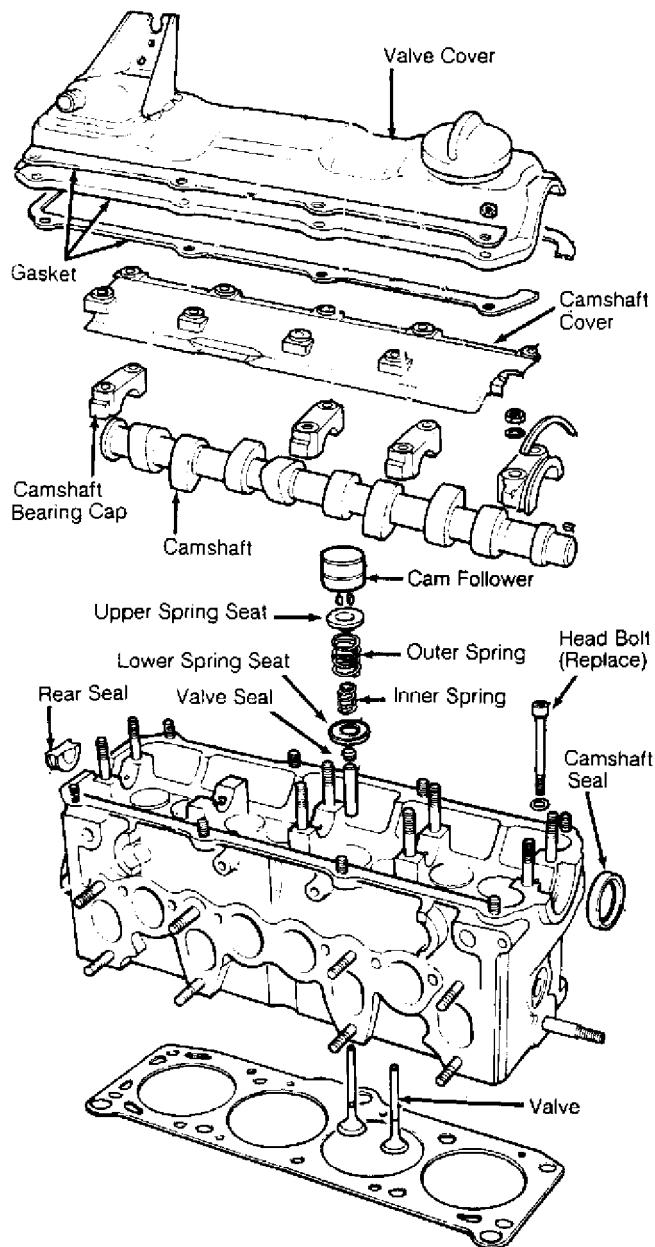

Fig. 4: Identifying 1.8L Cylinder Head (8-Valve)
 Courtesy of Volkswagen United States, Inc.

Inspection

Thoroughly clean all gasket mating surfaces. Check cylinder head for warpage. Maximum warpage is .004" (.10 mm). Check minimum cylinder head height and replace cylinder head (if necessary). The 1.8L cylinder head can be machined. DO NOT machine 2.0L (16-valve) cylinder head.

NOTE: DO NOT reuse antifreeze after replacing cylinder block, cylinder head, head gasket, radiator and/or heater core. The following **INSTALLATION** information is all that is available from manufacturer.

Installation

1) Ensure **OBEN** marking on cylinder head gasket faces up. Install gasket on cylinder block. Do not use any type of sealant. Align camshaft timing marks and position crankshaft at TDC.

2) Carefully position cylinder head on cylinder. Install head bolts No. 9 and 10 finger tight to ensure cylinder head position. Install remaining head bolts finger tight.

3) Tighten cylinder head bolts (in 3 steps) in sequence to specification. See Fig. 5. See **TORQUE SPECIFICATIONS** table at end of article.

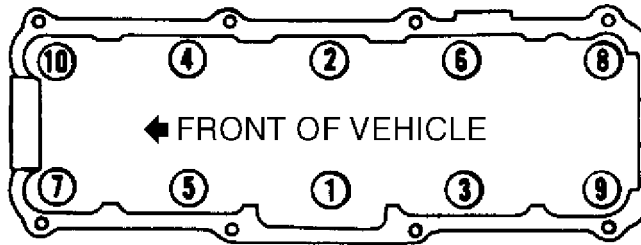

REMOVE IN REVERSE ORDER

G98953

Fig. 5: Cylinder Head Bolts Tightening Sequence
Courtesy of Volkswagen United States, Inc.

FRONT COVER OIL SEAL

Removal

1) Remove timing belt. See TIMING BELT under REMOVAL & INSTALLATION. Rotate inner part of Oil Seal Extractor (2085) outward 2 turns and tighten set screw. See Fig. 11.

2) Use bolt from Seal Installer (3083) as guide in center of oil seal extractor. Insert bolt through oil seal extractor and thread bolt all the way into crankshaft. Lubricate threaded area of extractor and push in as far as possible. Loosen set screw and turn inner part of extractor until oil seal is removed.

Installation

Lubricate outer edge and lip of new seal. Place guide sleeve from Seal Installer (3083) onto crankshaft. Push oil seal over guide sleeve. Press seal completely into position. To complete installation, reverse removal procedure.

TIMING BELT

Removal

Match mark all components to ensure reassembly in original position. See Fig. 6. DO NOT turn crankshaft with belt removed. Valve damage may result. No further removal information is available from manufacturer.

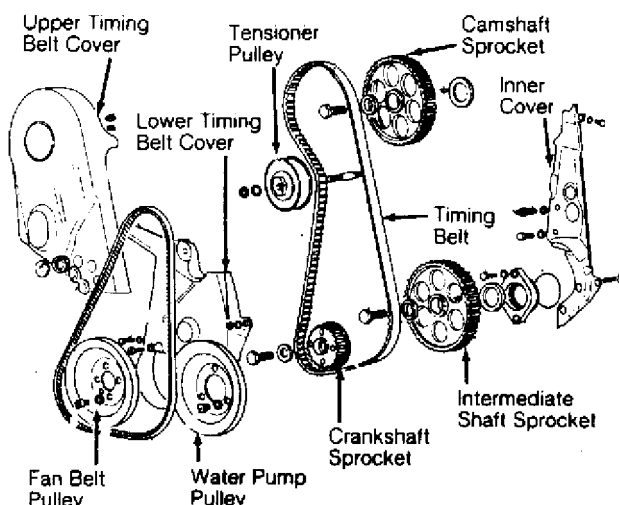

Fig. 6: Removing Timing Belt
Courtesy of Volkswagen United States, Inc.

Installation (1.8L)

1) Align flywheel/flex plate "0" mark with pointer. This is TDC. Remove distributor cap and check position of ignition rotor. Rotate intermediate shaft and position rotor at No. 1 cylinder mark on housing. See Fig. 7.

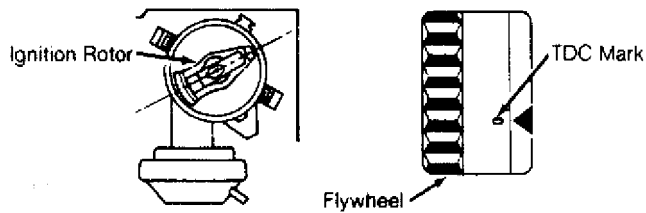

Fig. 7: Aligning Ignition Rotor (1.8L)
 Courtesy of Volkswagen United States, Inc.

2) With intermediate shaft/ignition rotor positioned, rotate crankshaft and align mark on crankshaft pulley with mark on intermediate shaft sprocket. Position camshaft sprocket mark even with valve cover surface. See Fig. 8. Install timing belt.

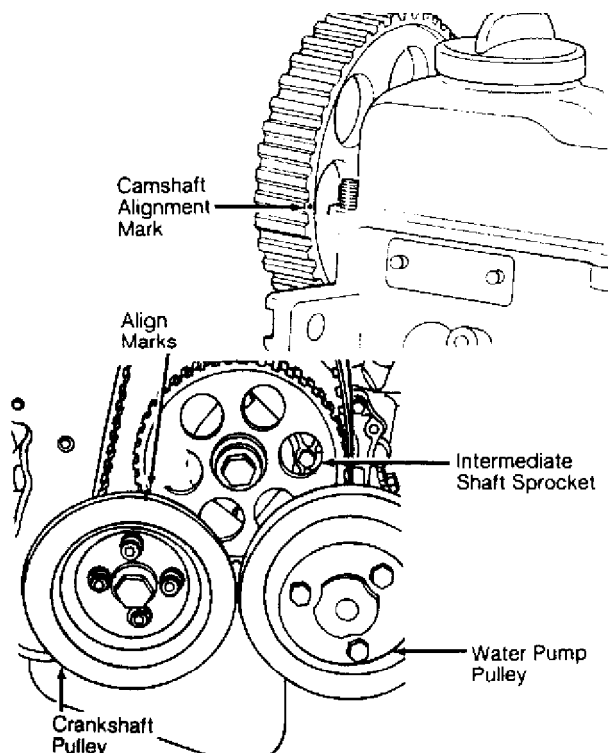

Fig. 8: Aligning 1.8L Timing Marks (8-Valve)
 Courtesy of Volkswagen United States, Inc.

3) Rotate tensioner clockwise to tighten belt and install lock nut. Proper deflection is achieved when longest span of belt between sprockets can be twisted 90 degrees. See Fig. 9. By hand, rotate crankshaft 2 turns and check timing mark alignment. To complete installation, reverse removal procedure.

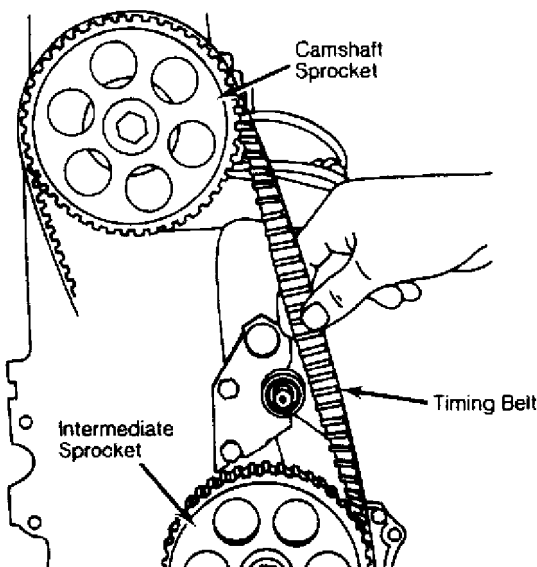

Fig. 9: Checking 1.8L Timing Belt Tension (8-Valve)
 Courtesy of Volkswagen United States, Inc.

Installation (2.0L)

1) Install timing belt around crankshaft and intermediate shaft sprockets. Install lower timing belt cover. Install vibration damper, noting offset holes.

2) If valve cover is installed, mark on front of camshaft sprocket must align with mark on valve cover. If valve cover is removed, place camshaft sprocket mark even with valve cover surface. See Fig. 10.

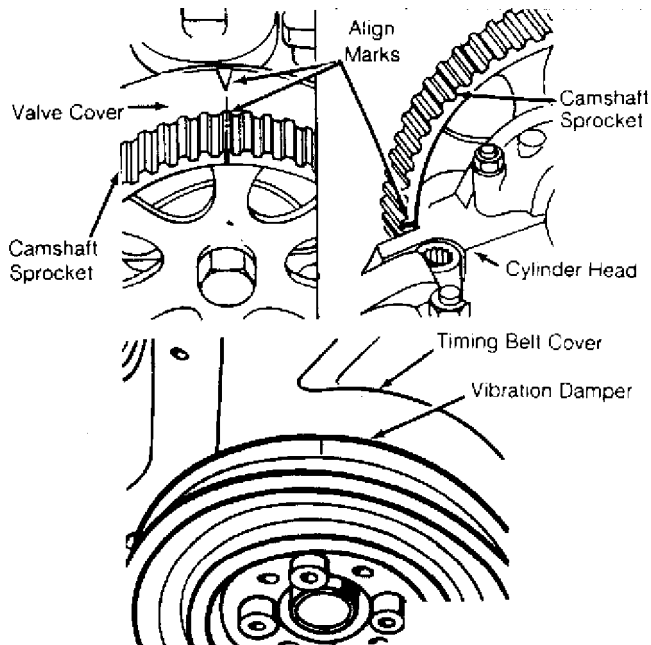

Fig. 10: Aligning 2.0L Timing Marks (16-Valve)
Courtesy of Volkswagen United States, Inc.

3) Align vibration damper mark with mark on lower timing belt cover. See Fig. 10. Install timing belt around camshaft sprocket. Install Timing Belt Tension Scale (VW 210). To tension belt, rotate belt tensioner clockwise until tension scale reads 13-14. By hand, rotate crankshaft 2 turns and check timing mark alignment. To complete installation, reverse removal procedure.

CAMSHAFT OIL SEAL

Removal

1) Remove upper timing belt cover. Place crankshaft at TDC with No. 1 cylinder on compression stroke. Remove timing belt from camshaft sprocket. Remove camshaft sprocket. Remove Woodruff key. Install camshaft sprocket bolt and washer until washer is tight against camshaft.

2) Rotate inner part of Oil Seal Extractor (2085) outward 2 turns and tighten set screw. See Fig. 11. Lubricate threaded area of extractor and push in as far as possible. Loosen set screw and turn inner part of extractor until oil seal is removed.

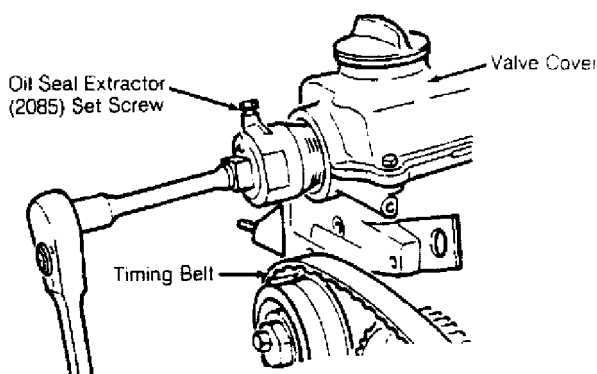

Fig. 11: Removing Camshaft Oil Seal
Courtesy of Volkswagen United States, Inc.

Installation

Coat new seal seat and lips lightly with engine oil. On 1.8L engines, using Installer (10-203), install seal until flush. On 2.0L engines, use Special Hex Head Bolt (10-203/1) to press seal into place. To complete installation, reverse removal procedure.

CAMSHAFT

Removal (1.8L)

1) Remove upper timing belt cover. See Fig. 6. Remove valve cover and camshaft cover. Place crankshaft at TDC with No. 1 cylinder on compression stroke. Remove timing belt from camshaft sprocket. Remove camshaft sprocket. Remove Woodruff key. Check camshaft end play with cam followers removed and bearing caps No. 1 and 5 installed. See CAMSHAFT table under ENGINE SPECIFICATIONS at end of article.

2) Remove bearing caps No. 1, 3 and 5 evenly a little at a time. Repeat for remaining caps. Remove camshaft.

Inspection

Check camshaft bearing oil clearance. See CAMSHAFT table under ENGINE SPECIFICATIONS at end of article. If oil clearance exceeds specification, install new camshaft and recheck clearance. If clearance still exceeds specification, replace cylinder head.

Installation

1) On engines with oil spray jets, position spray at right angle to camshaft. Place camshaft in cylinder head with both high points of lobes, for No. 1 cylinder facing upward. Install bearing caps No. 1, 3 and 5.

2) Tighten evenly a little at a time. Repeat procedure for remaining bearing caps. To complete installation, reverse removal procedure. Ensure timing marks are properly aligned. Before starting engine, allow 30 minutes for cam followers to bleed down.

Removal (2.0L)

1) Remove upper timing belt cover. Remove camshaft cover. See Figs. 3 and 6. Place crankshaft at TDC with No. 1 cylinder on compression stroke. Remove timing belt from camshaft sprocket. Remove camshaft sprocket. Remove Woodruff key. Check camshaft end play with cam followers removed and bearing caps No. 1 and 4 (exhaust camshaft) or 5 and 8 (intake camshaft) installed. See CAMSHAFT table under ENGINE SPECIFICATIONS at end of article.

2) Remove intake camshaft bearing caps No. 5, 7 and rear cap evenly a little at a time. See Fig. 12. Loosen remaining intake camshaft bearing caps evenly a little at a time. Remove exhaust camshaft bearing caps No. 1, 3, front cap and rear cap evenly a little at a time. Loosen remaining exhaust camshaft bearing caps evenly a little at a time. Remove camshaft bearing caps. Lift both camshafts out of cylinder head together.

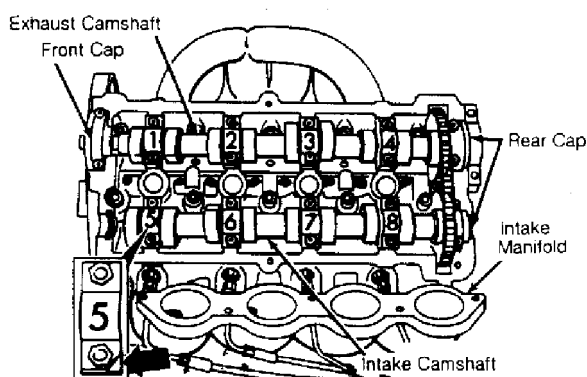

Fig. 12: Identifying Camshaft Bearing Caps (2.0L)
Courtesy of Volkswagen United States, Inc.

Inspection

Check camshaft bearing oil clearance. See CAMSHAFT table under ENGINE SPECIFICATIONS at end of article. If oil clearance is not within specification, install new camshaft and recheck clearance. If clearance still exceeds specification, replace cylinder head.

Installation

1) Place drive chain on both camshaft gears. Align matching marks on gears and place both camshafts in cylinder head. See Fig. 13.

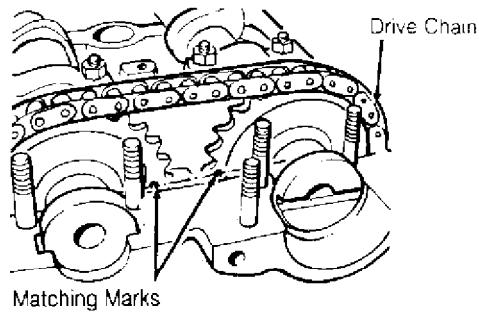

Fig. 13: Aligning Camshaft Gears & Drive Chain (16-Valve)
Courtesy of Volkswagen United States, Inc.

2) Install intake camshaft bearing caps No. 6 and 8 and tighten evenly a little at a time. See Fig. 12. Repeat procedure for remaining intake camshaft bearing caps. Install exhaust camshaft bearing caps No. 2 and 4. Tighten evenly a little at a time. Repeat procedure for remaining exhaust camshaft bearing caps. To complete installation, reverse removal procedure. Before starting engine, allow 30 minutes for cam followers to bleed down.

INTERMEDIATE SHAFT

Removal & Installation

1) Remove timing belt. See TIMING BELT under REMOVAL & INSTALLATION. Mark distributor assembly for installation reference and remove distributor assembly.

2) Ensure intermediate shaft end play does not exceed .010" (.25 mm). Remove intermediate shaft sprocket. Remove intermediate shaft seal flange. Remove intermediate shaft. Replace seal (if necessary). See Fig. 16. To install, reverse removal procedure.

REAR CRANKSHAFT OIL SEAL

Removal & Installation

Remove flywheel/flexplate, and discard bolts. See Fig. 16. Remove retaining flange. Remove rear crankshaft oil seal. Use Installer (2003/1) to install seal. To complete installation, reverse removal procedure. Install new flywheel/flex plate bolts.

WATER PUMP

CAUTION: Coolant/water mixture should be used at all times. Use only ethylene glycol based (phosphate-free) coolant.

Removal & Installation

1) Disconnect negative battery cable. Turn heater control to hot. Drain cooling system. Remove accessories and brackets (as necessary).

2) Label and remove coolant hoses from water pump. Remove water pump pulley. See Fig. 8. Remove bolts and remove water pump assembly. To install, reverse removal procedure. To fill cooling system, remove thermo time switch, located on water flange.

OIL PAN

Oil pan can be removed and installed with engine in vehicle. No further information is available from manufacturer.

OVERHAUL

CYLINDER HEAD

Cylinder Head

Clean all gasket mating surfaces. Check cylinder head for warpage. See CYLINDER HEAD table under ENGINE SPECIFICATIONS at end of article. The 1.8L cylinder head can be machined. DO NOT machine 2.0L (16-valve) cylinder head.

Valve Stem Oil Seals

On 1.8L heads, install seals using Valve Seal Replacer/Sleeve (10-204). On 2.0L (16-valve) heads, remove seals using Seal Remover (3047) and install seals using Valve Seal Replacer/Sleeve (3129). DO NOT install valve seal without using sleeve.

Valve Springs

No information is available from manufacturer.

Valve Guides

Check valve-to-guide clearance specification. See CYLINDER HEAD table under ENGINE SPECIFICATIONS at end of article. To replace valve guide, press guide out from combustion chamber side. Press guide in cold cylinder head as far as guide will go. DO NOT exceed one ton pressure. Ream guides to proper valve-to-guide clearance. See CYLINDER HEAD table under ENGINE SPECIFICATIONS at end of article.

Valve Seats

1) Check valve seats before any other cylinder head service. Insert the valve and hold firmly against the valve seat. Measure valve stem tip-to-cylinder head distance. See Fig. 14.

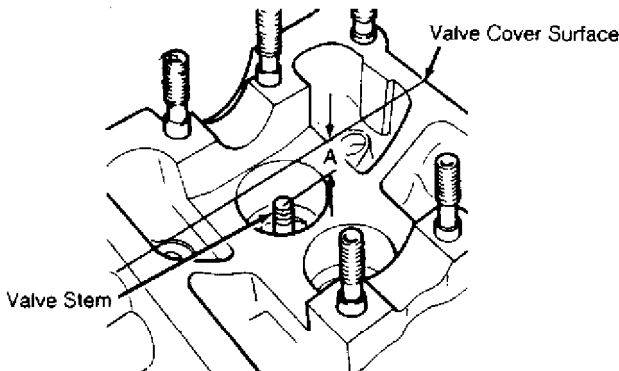

Fig. 14: Measuring Valve Installed Height Courtesy of Volkswagen United States, Inc.

2) This measurement determines installed valve height. Subtract measured distance from minimum specification. See MINIMUM VALVE INSTALLED HEIGHT table.

MINIMUM VALVE INSTALLED HEIGHT TABLE

AA
 Application In. (mm)

1.8L		
Intake Valve	1.331 (33.80)
Exhaust Valve	1.343 (34.10)

2.0L

Intake Valve	(1) 1.354 (34.40)
Exhaust Valve	(1) 1.366 (34.70)

(1) - DO NOT remove more than .079" (2.0 mm) of material from valve and/or valve seat.

AA

3) The difference is maximum refacing allowable for valve and seat. If valve installed height is too high, replace cylinder head assembly. If valve installed height is too low or too high, cam followers will not work correctly.

Valves

Measure valve stem diameter and valve margin. If not within specification, replace valves. DO NOT reface exhaust valves (or intake valves on 2.0L engines) with machine. Lap valves by hand or replace as necessary. See VALVES & VALVE SPRINGS table under ENGINE SPECIFICATIONS at end of article.

CYLINDER BLOCK ASSEMBLY

Piston & Rod Assembly

1) Make sure piston, rod and rod caps are marked with matching cylinder number prior to removal. Ensure engine front arrow is marked on top of piston and front mark exists on rod and cap. See Fig. 15. Pistons and rods are to be replaced in sets of 4. Rod cap bolts and nuts must be replaced after removing or loosening.

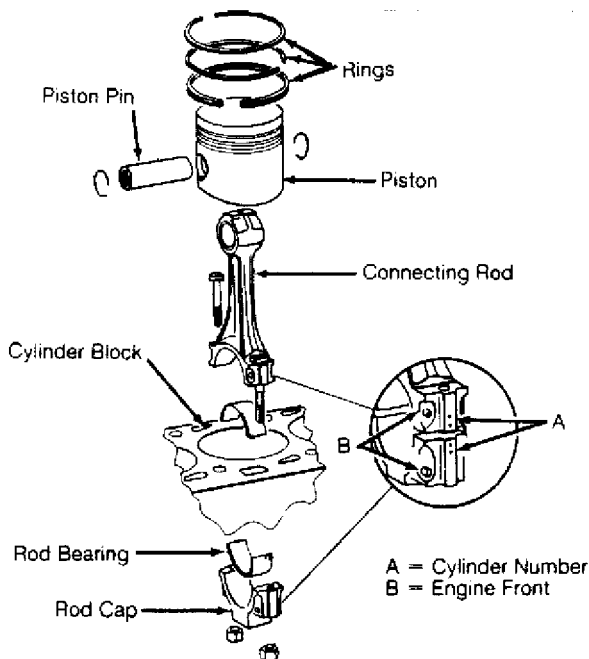

Fig. 15: Assembling Piston & Rod
Courtesy of Volkswagen United States, Inc.

2) Mark piston in relation to pin. Remove circlips from ends of pin bore. Use Piston Pin Replacer/Installer (VW 207C) for 1.8L engines or Piston Pin Replacer/Installer (VW 222A) for 2.0L engines to remove and install piston pin. If pin is too tight, heat piston to 140øF (60øC). Ensure rod is properly positioned with piston. See Fig. 15.

Fitting Pistons

Measure clearances with cylinder block supported on work bench. Check clearance of piston-to-cylinder bore. Piston diameter is stamped on top of piston in millimeters.

PISTON-TO-CYLINDER BORE DIMENSIONS TABLE

Size	Piston Diameter		Cylinder Bore	
	In. (mm)		In. (mm)	
1.8L				
Standard	3.188 (80.98)	3.189 (81.01)
1st Over	3.198 (81.23)	3.199 (81.26)
2nd Over	3.208 (81.48)	3.209 (81.51)
2.0L				
Standard	3.247 (82.48)	3.248 (82.51)
1st Over	3.257 (82.73)	3.258 (82.76)
2nd Over	3.267 (82.98)	3.268 (83.01)

Piston Rings

Measure ring end gap. Measure ring side clearance with piston. If not within specification, replace as necessary. See PISTONS, PINS & RINGS table under ENGINE SPECIFICATIONS at end of article. Install rings on piston with TOP mark facing upward. Recessed edge on outside of center ring must face piston pin (down). Position ring gaps on piston at 120 degree intervals. See Fig. 15.

Rod Bearings

Mark rod caps for reinstallation. Use Plastigage to measure bearing clearances. Measure connecting rod side play. Replace or machine as necessary. See CRANKSHAFT, MAIN & CONNECTING ROD BEARINGS table under ENGINE SPECIFICATIONS at end of article. Tighten evenly to specification in several steps. See TORQUE SPECIFICATIONS table at end of article.

Crankshaft & Main Bearings

Main bearing caps are marked with matching journal for installation in original position. See Fig. 16. Measure crankshaft end play. See THRUST BEARING.

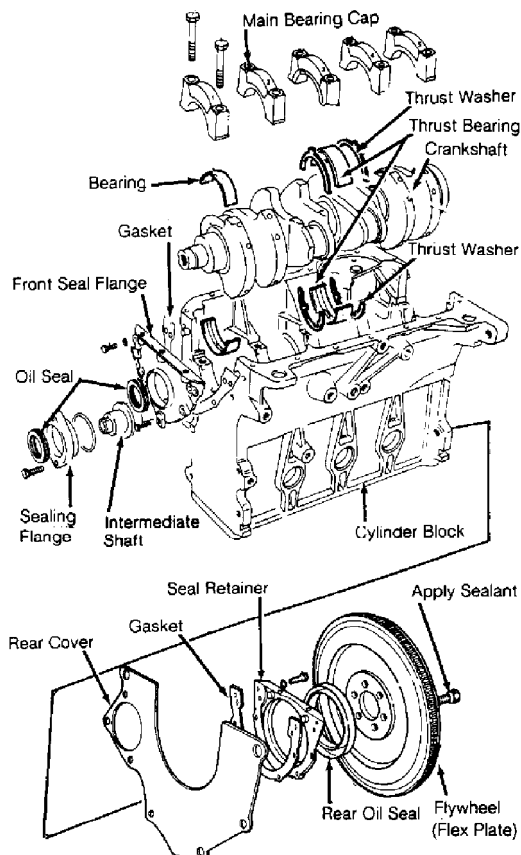

Fig. 16: Crankshaft Assembly
 Courtesy of Volkswagen United States, Inc.

Thrust Bearing

Insert feeler gauge between No. 3 main bearing and crankshaft thrust face to measure end play. See Fig. 16. Replace thrust bearing as necessary. See CRANKSHAFT, MAIN & CONNECTING ROD BEARINGS table under ENGINE SPECIFICATIONS at end of article.

Cylinder Block

Measure cylinder block while supported on work bench. Check cylinder bore for wear, out-of-round and taper. Check cylinder block for warpage. See CYLINDER BLOCK table under ENGINE SPECIFICATIONS at end of article.

ENGINE OILING

ENGINE LUBRICATION SYSTEM

Crankcase Capacity

See CRANKCASE CAPACITY table.

CRANKCASE CAPACITY TABLE

Model	With Filter Replacement	Without Filter Replacement
Fox	3.7 Qts. (3.5L)	3.2 Qts. (3.0L)
Except Fox	4.2 Qts. (4.0L)	3.7 Qts. (3.5L)

Oil Pressure

Check oil pressure with engine at warm operating temperature. Minimum oil pressure at idle is 4.3 psi (.3 kg/cm²). Minimum oil pressure at 2000 RPM is 29 psi (2.0 kg/cm²).

OIL PUMP

Removal & Installation

Remove oil pan. Remove oil pump attaching bolts and remove oil pump assembly. To install, reverse removal procedure.

Inspection

Check oil pump backlash and oil pump axial play. If not within specification, replace oil pump assembly. See OIL PUMP SPECIFICATIONS table.

OIL PUMP SPECIFICATIONS TABLE

Application	In. (mm)
Backlash	
New002 (.05)
Limit008 (.20)
Axial Play Limit006 (.15)

TORQUE SPECIFICATIONS

TORQUE SPECIFICATIONS TABLE

Application	Ft. Lbs. (N.m)
A/C Bracket-To-Engine Bolt	22 (30)
Axle Shaft-To-Transaxle Drive Flange Bolt	33 (45)
Camshaft Bearing Cap Bolt	

8V	15 (20)
16V	11 (15)
Camshaft Drive Gear Bolt (2.0L)	
GTI & Jetta GLi	59 (80)
Passat	48 (65)
Clutch Cover Bolt	15 (20)
Crankshaft Main Bearing Cap Bolt	50 (65)
Crankshaft Timing Sprocket Bolt	66 (90) + 1/2 Turn
Cylinder Head Nut	
Step 1	30 (40)
Step 2	44 (60)
Step 3	Additional 1/2 (180°) Turn
Engine Bracket-To-Hydraulic Mount Bolt	44 (60)
Engine Mount Carrier-To-Frame Bolt	(1)
Engine Mounts	(1)
Engine-To-Transaxle 10-mm Bolt	33 (45)
Engine-To-Transaxle 12-mm Bolt	41 (55)
Exhaust Manifold-To-Cylinder Head Bolt & Nut	18 (25)
Exhaust Pipe-To-Manifold Nut	22 (30)
Exhaust Pipe-To-Support Bracket Bolt	18 (25)
Flywheel or Pressure Plate-To-Crankshaft ..	22 (30)+1/4 Turn
Front Exhaust Pipe-To-Manifold Bolt	30 (40)
G-Charger Pulley Bolt	18 (25)
G-Charger-To-Block	26 (35)
Intake Manifold	18 (25)
Intermediate Shaft Sprocket Bolt	59 (80)
Knock Sensor	15-18 (20-25)
Lower Pulley Bolt	15 (20)
Oil Pan Bolt	15 (20)
Oil Pan Drain Plug	22 (30)
Oil Pump Cover Short Bolt	7 (10)
Oil Pump Cover Long Bolt	15 (20)
Rod Bearing Cap Nut	22 (30) + 1/4 Turn
Starter Mount Bolt	18 (25)
Timing Belt Tensioner Nut	33 (45)
Torque Converter-To-Carrier Plate Bolt	22 (30)
Water Pump Pulley Bolt	15 (20)
Water Pump Housing-To-Engine Bolt	15 (20)

INCH Lbs. (N.m)

Piston Oil Jet Nozzle	89 (10)
Transaxle/Engine Cover Plate Bolt	89 (10)
Valve Cover Retaining Nut	89 (10)
Water Pump-To-Housing	89 (10)

(1) - See Fig. 2.

AA

ENGINE SPECIFICATIONS

GENERAL ENGINE SPECIFICATIONS

GENERAL SPECIFICATIONS TABLE

AA

Application	Specification
-------------	---------------

1.8L	
Displacement	109 Cu. In. (1.8L)
Bore	3.19" (81.0 mm)
Stroke	3.40" (86.4 mm)
Compression Ratio	
Cabriolet	8.5:1
Corrado	(1) 8.0:1

CONNECTING RODS SPECIFICATIONS

CONNECTING RODS TABLE

Application	In. (mm)
Bore Diameter	
Pin Bore	.787 (20.00)
Crankpin Bore	1.992 (50.60)
Center-To-Center Length	5.669 (144.00)
Side Play	
Except Passat	.015 (.37)
Passat	.002-.005 (.05-.13)

PISTONS, PINS & RINGS SPECIFICATIONS

PISTONS, PINS & RINGS TABLE

Application	In. (mm)
Pistons	
Clearance	.0016 (.040)
Diameter	
1.8L	3.187 (80.96)
2.0L	3.246-3.247 (82.44-82.48)
Pins	
Diameter	.787 (20.00)
Piston Fit	Interference
Rod Fit	Interference
Rings	
No. 1	
End Gap	
Standard	.012-.018 (.30-.45)
Service Limit	.039 (1.0)
Side Clearance	
Standard	.001-.002 (.02-.05)
Service Limit	.006 (.15)
No. 2	
End Gap	
Standard	.012-.018 (.30-.45)
Service Limit	.039 (1.0)
Side Clearance	.001-.002 (.02-.05)
No. 3 (Oil)	
End Gap	
Standard	.010-.018 (.25-.45)
Service Limit	.039 (1.0)
Side Clearance	.001-.002 (.02-.05)

CYLINDER BLOCK SPECIFICATIONS

CYLINDER BLOCK TABLE

Application	In. (mm)
Cylinder Bore	
Standard Diameter	
1.8L	3.189 (81.01)
2.0L	3.248 (82.51)
Maximum Taper	.0016 (.04)
Maximum Out-of-Round	.001 (.03)

VALVES & VALVE SPRINGS SPECIFICATIONS

VALVES & VALVE SPRINGS TABLE

AA

Application Specification

1.8L	
Intake Valves	
Face Angle	45ø
Head Diameter	1.496" (38.00 mm)
Length	
Except Corrado	3.583" (91.00 mm)
Corrado	3.598" (91.40 mm)
Minimum Margin	(1)
Stem Diameter314" (7.97 mm)
Exhaust Valves	
Face Angle	45ø
Head Diameter	1.299" (33.00 mm)
Length	
Cabriolet & Fox	3.575" (90.80 mm)
Corrado	3.598" (91.40)
Minimum Margin	(2)
Stem Diameter313" (7.95 mm)
2.0L	
Intake Valves	
Face Angle	45ø
Head Diameter	1.260" (32.00 mm)
Length	3.760" (95.50 mm)
Minimum Margin	(2)
Stem Diameter274" (6.97 mm)
Exhaust Valves	
Face Angle	45ø
Head Diameter	1.102" (28.00 mm)
Length	3.866" (98.20 mm)
Minimum Margin	(2)
Stem Diameter313" (7.95 mm)

- (1) - No information is available from manufacturer.
- (2) - DO NOT machine valves; hand lap only.

AA

CYLINDER HEAD SPECIFICATIONS

CYLINDER HEAD TABLE

AA

Application Specification

Cylinder Head Height	
1.8L (Minimum)	5.220" (132.60 mm)
2.0L (Minimum)	4.650" (118.10 mm)
Maximum Warpage039" (1.00 mm)
Valve Seats	
Intake Valve	
Seat Angle	45ø
Seat Width	
1.8L079" (2.00 mm)
2.0L059-.071" (1.50-1.80 mm)
Exhaust Valve	
Seat Angle	45ø
Seat Width	
Except Fox071-.079" (1.80-2.00 mm)
Fox094" (2.40 mm)
Valve Guides	

Intake Valve
 Valve Guide Installed Height (1)
 Oil Clearance (2) .039" (1.0 mm)
 Exhaust Valve
 Valve Guide Installed Height (1)
 Valve Stem-to-Guide
 Oil Clearance (2) .051" (1.30 mm)

- (1) - Valve guide shoulder flush with cylinder head.
- (2) - New valve installed in cylinder head. Dial indicator used to measure valve rock in guide.

AA

CAMSHAFT SPECIFICATIONS

CAMSHAFT TABLE

AA

Application	In. (mm)
End Play006 (.15)
Oil Clearance004 (.10) Maximum

AA

END OF ARTICLE